



Top Freezer Cycle-Defrost Refrigerators

Safety Information2-4

Operating Instructions
Control5
Features5

Care and Cleaning
Cleaning6, 7

Installation Instructions
Preparing to Install
the Refrigerator8
Reversing the Door Swing9, 10

Troubleshooting Tips11, 12

Consumer Support
Product Registration13, 14
Consumer SupportBack Cover
Warranty15

**Owner's Manual and
Installation Instructions**

Model 12

**Write the model and serial
numbers here:**

Model # _____

Serial # _____

You can find them on a label
inside the refrigerator on the
upper left side wall.



IMPORTANT SAFETY INFORMATION. READ ALL INSTRUCTIONS BEFORE USING.

⚠ **WARNING!**

Use this appliance only for its intended purpose as described in this Owner's Manual.



SAFETY PRECAUTIONS

When using electrical appliances, basic safety precautions should be followed, including the following:

- This refrigerator must be properly installed and located in accordance with the Installation Instructions before it is used.
- Do not allow children to climb, stand or hang on the shelves in the refrigerator. They could damage the refrigerator and seriously injure themselves.
- Do not touch the cold surfaces in the freezer compartment, particularly when hands are damp or wet. Skin may stick to these extremely cold surfaces.
- Do not store or use gasoline or other flammable vapors and liquids in the vicinity of this or any other appliance.
- In refrigerators with automatic icemakers, avoid contact with the moving parts of the ejector mechanism, or with the heating element that releases the cubes. Do not place fingers or hands on the automatic icemaking mechanism while the refrigerator is plugged in.
- Keep fingers out of the “pinch point” areas; clearances between the doors and between the doors and cabinet are necessarily small. Be careful closing doors when children are in the area.
- Unplug the refrigerator before cleaning and making repairs.
NOTE: We strongly recommend that any servicing be performed by a qualified individual.
- Turning the control to the **OFF** position does not remove power to the light circuit.
- Do not refreeze frozen foods which have thawed completely.

IMPORTANT: PROPER DISPOSAL OF THE REFRIGERATOR

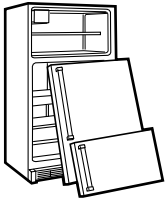

Child entrapment and suffocation are not problems of the past. Junked or abandoned refrigerators are still dangerous...even if they will sit for "just a few days." If you are getting rid of your old refrigerator, please follow the instructions below to help prevent accidents.

Before You Throw Away Your Old Refrigerator or Freezer:

- Take off the doors.
- Leave the shelves in place so that children may not easily climb inside.

CFC Disposal

Your old refrigerator has a cooling system that used CFCs (chlorofluorocarbons). CFCs are believed to harm stratospheric ozone.

If you are throwing away your old refrigerator, make sure the CFC refrigerant is removed for proper disposal by a qualified servicer. If you intentionally release this CFC refrigerant you can be subject to fines and imprisonment under provisions of the Federal Clean Air Act.



USE OF EXTENSION CORDS

Because of potential safety hazards under certain conditions, we strongly recommend against the use of an extension cord.

However, if you must use an extension cord, it is absolutely necessary that it be a UL-listed (in the United States) or a CSA-listed (in Canada), 3-wire grounding type appliance extension cord having a grounding type plug and outlet and that the electrical rating of the cord be 15 amperes (minimum) and 120 volts.

IMPORTANT SAFETY INFORMATION. READ ALL INSTRUCTIONS BEFORE USING.

⚠ **WARNING!**

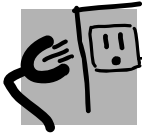

HOW TO CONNECT ELECTRICITY

Do not, under any circumstances, cut or remove the third (ground) prong from the power cord. For personal safety, this appliance must be properly grounded.

The power cord of this appliance is equipped with a 3-prong (grounding) plug which mates with a standard 3-prong (grounding) wall outlet to minimize the possibility of electric shock hazard from this appliance.

Have the wall outlet and circuit checked by a qualified electrician to make sure the outlet is properly grounded.

Where a standard 2-prong wall outlet is encountered, it is your personal responsibility and obligation to have it replaced with a properly grounded 3-prong wall outlet.

The refrigerator should always be plugged into its own individual electrical outlet which has a voltage rating that matches the rating plate.

This provides the best performance and also prevents overloading house wiring circuits which could cause a fire hazard from overheated wires.

Never unplug your refrigerator by pulling on the power cord. Always grip plug firmly and pull straight out from the outlet.

Repair or replace immediately all power cords that have become frayed or otherwise damaged. Do not use a cord that shows cracks or abrasion damage along its length or at either end.

When moving the refrigerator away from the wall, be careful not to roll over or damage the power cord.



USE OF ADAPTER PLUGS *(Adapter plugs not permitted in Canada)*

Because of potential safety hazards under certain conditions, we strongly recommend against the use of an adapter plug.

However, if you must use an adapter, where local codes permit, a **temporary connection** may be made to a properly grounded 2-prong wall outlet by use of a UL-listed adapter available at most local hardware stores.

The larger slot in the adapter must be aligned with the larger slot in the wall outlet to provide proper polarity in the connection of the power cord.

When disconnecting the power cord from the adapter, always hold the adapter in place with one hand while pulling the power cord plug with the other hand. If this is not done, the adapter ground terminal is very likely to break with repeated use.

If the adapter ground terminal breaks, **DO NOT USE** the refrigerator until a proper ground has been established.

Attaching the adapter ground terminal to a wall outlet cover screw does not ground the appliance unless the cover screw is metal, and not insulated, and the wall outlet is grounded through the house wiring. You should have the circuit checked by a qualified electrician to make sure the outlet is properly grounded.



READ AND FOLLOW THIS SAFETY INFORMATION CAREFULLY.

SAVE THESE INSTRUCTIONS

About the control on the refrigerator.

www.GEAppliances.com

The temperature control on your refrigerator regulates the temperature in the fresh food and freezer compartments. Initially set the control at 4.

If you want colder or warmer temperatures, move the dial one number at a time. After changing the control, allow 12 hours for the refrigerator to reach the temperature you have set.

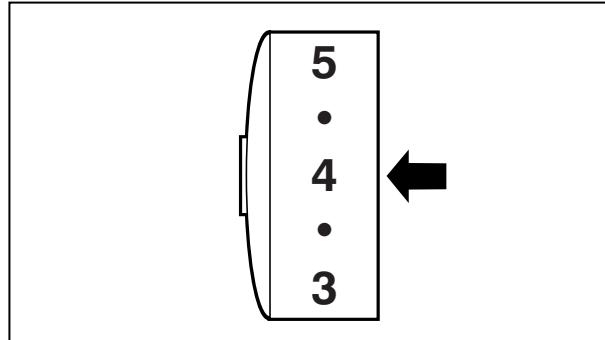

Control Settings

The temperature control maintains the temperature in both the fresh food and freezer compartments. Setting **1** is the warmest setting and **7** is the coldest. Moving the control to **OFF** stops cooling in both areas—fresh food and freezer—but does not shut off power to the refrigerator. Moving the control to the **OFF** position will require extra force to click into position.

Control setting will vary based on personal preferences, usage, and operating conditions and may require more than one adjustment.

About the storage features.

Fruit and Vegetable Drawers

The storage drawers at the bottom of the fresh food compartment have been specially designed to help preserve fruits and vegetables.

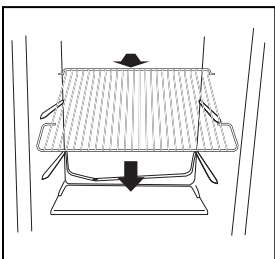

Shelves

To remove a shelf, remove food from it, lift up the rear of the shelf and pull forward.

To remove a shelf when the door cannot be opened fully, remove food from it, lift up the rear of the shelf and pull forward and down. Then tilt the shelf and take it out.

Shelf guards on the rear of the shelves in the fresh food compartment help prevent containers from touching the cooling plate.

If bowls or similar containers touch the plate, frost could form on the containers and cause partial freezing of their contents. This frost may melt and drip during the defrosting cycle.

Care and cleaning of the refrigerator.

Cleaning the Outside

The recessed door handles can be cleaned with a cloth dampened with a solution of mild liquid dishwashing detergent and water. Dry with a soft cloth. Don't use wax on the door handles.

Keep the finish clean. Wipe with a clean cloth lightly dampened with kitchen appliance detergent. Dry and polish with a clean, soft cloth. Do not wipe the refrigerator with a soiled dishwashing cloth or wet towel. These may leave a residue that can erode the paint. Do not use scouring pads, powdered cleaners, bleach or cleaners containing bleach because these products can scratch and weaken the paint finish.

Protect the paint finish. The finish on the outside of the refrigerator is a high quality, baked-on paint finish. With proper care, it will stay new-looking and rust-free for years. Apply a coat of kitchen/appliance wax when the refrigerator is new and then at least twice a year.

Appliance Polish Wax & Cleaner is available from GE Appliance Service and Parts Centers.

Cleaning the Inside

Inside the fresh food and freezer compartments should be cleaned at least once a year. Unplug the refrigerator before cleaning. If this is not practical, wring excess moisture out of sponge or cloth when cleaning around switches, lights or controls.

Use warm water and baking soda solution—about a tablespoon of baking soda to a quart of water. This both cleans and neutralizes odors. Rinse thoroughly with water and wipe dry.

Other parts of the refrigerator, including door gasket, vegetable drawer, ice trays and all plastic parts, can be cleaned the same way. Do not use cleansing powders or other abrasive cleaners.

To help prevent odors, leave an open box of baking soda in the rear of the refrigerator, on the top shelf. Change the box every three months.

An open box of baking soda in the freezer will absorb stale freezer odors.

Do not wash any plastic parts from your refrigerator in your automatic dishwasher.

Defrosting—Fresh Food Compartment

Defrosting of the fresh food compartment takes place automatically every time the refrigerator cycles off.

Melted frost water drains from the cooling plate into a trough below the plate and down into a pan near the bottom of the refrigerator (see Defrost Water Pan section) where it evaporates.

NOTE: Be sure bowls or similar objects are not touching the rear wall of the fresh food compartment. If they are, frost may form on them and drip into fresh food compartment during defrosting.

Defrosting—Freezer Compartment

■ Defrost freezer compartment when frost becomes 1/4" to 1/2" thick in any area of the freezer.

■ It may be necessary to defrost the freezer compartment frequently if the freezer is used often and/or there is high humidity.

NOTE: Do not use any electrical device or sharp instrument in defrosting your freezer compartment.

To defrost freezer compartment:

① Remove contents from freezer compartment and turn temperature control to the **OFF** position. Temperature control must remain at the **OFF** position and freezer compartment door must stay open.

To reduce the amount of thawing of frozen food while defrosting the freezer compartment, store the food in a picnic cooler or other insulated container.

② Use a plastic scraper to loosen and remove frost from the ceiling and walls of the freezer compartment as the frost begins to thaw. Do not use a sharp or pointed instrument to remove frost—its use may result in damage to the refrigerator system. To speed frost removal, place pans of hot tap water in the freezer compartment.

③ Sponge up defrost water as it collects in bottom of freezer compartment. Place a large folded bath towel at the front of the freezer compartment to soak up water and prevent it from running down the front of the refrigerator.

④ After defrosting is completed, turn temperature control to desired setting and wait two hours before placing frozen food back into the freezer compartment.

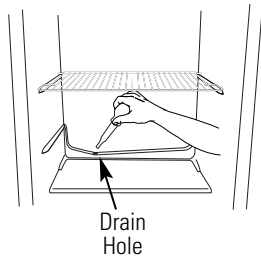

Drain Opening in Fresh Food Compartment

During yearly cleaning, flush a solution of baking soda (one teaspoon) and two cups of hot (not boiling) water through the drain line with the help of a meat baster. This will help eliminate odor and reduce the likelihood of a clogged drain.

Behind Refrigerator

Care should be taken in moving your refrigerator away from the wall. All types of floor coverings can be damaged, particularly cushioned coverings and those with embossed surfaces. When pushing the refrigerator back, make sure you don't slide over the power cord.

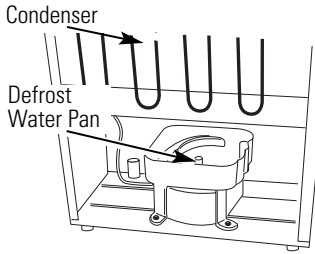

Condenser

For most efficient operation, the condenser, located on the back of the refrigerator, should be cleaned at least once a year. Pull the refrigerator away from the wall and use a non-metallic brush or a vacuum cleaner attachment to remove any accumulated dust.

Defrost Water Pan

The pan located below the condenser should be cleaned at least once a year. **DO NOT REMOVE THE PAN.** Move the refrigerator out from the wall as far as necessary, and unplug the power cord from the wall outlet before cleaning the pan. Use a clean cloth or sponge dampened in warm water and baking soda solution—one tablespoon of baking soda to a quart of water. **Do not use** cleansing powders, abrasive cleaners, bleach or cleaners containing chlorides.

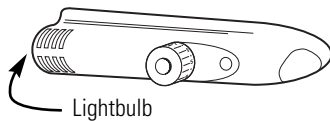

Lightbulb Replacement

The lightbulb is located behind the temperature control.

- 1 Unplug the refrigerator.
- 2 Reach behind the light shield and remove the bulb.
- 3 Replace with a bulb of the same type and wattage.
- 4 Plug the refrigerator back in.

Preparing for Vacation

For extended vacations or absences, remove food and unplug the refrigerator. Move the control to the **OFF** position, and clean the interior with a baking soda solution of one tablespoon of baking soda to one quart of water. Leave the doors open.

Preparing to Move

Secure all loose items such as grille, shelves and drawers by taping them securely in place to prevent damage.

Be sure the refrigerator stays in an upright position during moving.

Installation Instructions

Refrigerator

Model 12

If you have questions, call 800-GECARES or visit our Website at: www.GEAppliances.com

BEFORE YOU BEGIN

Read these instructions completely and carefully.

- **IMPORTANT** — Save these instructions for local inspector's use.
- **IMPORTANT** — Observe all governing codes and ordinances.
- **Note to Installer** — Be sure to leave these instructions with the Consumer.
- **Note to Consumer** — Keep these instructions for future reference.
- **Skill level** — Installation of this appliance requires basic mechanical skills.
- **Completion time** — Refrigerator Installation
15 minutes
Reversing the Door Swing
1 hour
- Proper installation is the responsibility of the installer.
- Product failure due to improper installation is not covered under the Warranty.

REFRIGERATOR LOCATION

- Do not install the refrigerator where the temperature will go below 55°F (13°C) because it will not run often enough to maintain proper temperatures.
- Install it on a floor strong enough to support it fully loaded.

CLEARANCES

Allow the following clearances for ease of installation and proper air circulation.

- Sides 1/2"
- Top 1/2"
- Back 1"

LEVELING LEGS

Adjustable legs at the front corners of the refrigerator should be set so the refrigerator is firmly positioned on the floor and the front is raised just enough that the door closes easily when opened about halfway.

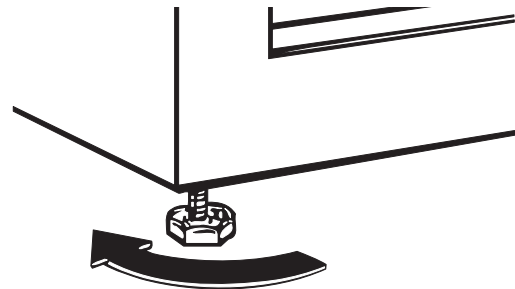

To raise the refrigerator

To adjust the leveling legs, turn the legs clockwise to raise the refrigerator, counterclockwise to lower it.

Installation Instructions

REVERSING THE DOOR SWING

IMPORTANT NOTES

When reversing the door swing:

- Read the instructions all the way through before starting.
- Handle parts carefully to avoid scratching paint.
- Set screws down by their related parts to avoid using them in the wrong places.
- Provide a non-scratching work surface for the doors.

IMPORTANT: Once you begin, do not move the cabinet until door-swing reversal is completed.

These instructions are for changing the hinges from the right side to the left side—if you ever want to change the hinges back to the right side, follow these same instructions and reverse all references to left and right.

Unplug the refrigerator from its electrical outlet.

Empty all door shelves.

TOOLS YOU WILL NEED



5/16" Head socket driver



7/32" Head socket driver



Phillips screwdriver

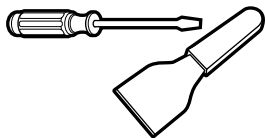

Putty knife or thin-blade screwdriver

1 REMOVE THE FREEZER DOOR

Remove the top hinge cover, hinge and washer. Set them aside.

Move the plug buttons from the top of the freezer door on the opposite side to the holes left vacant by the hinge.

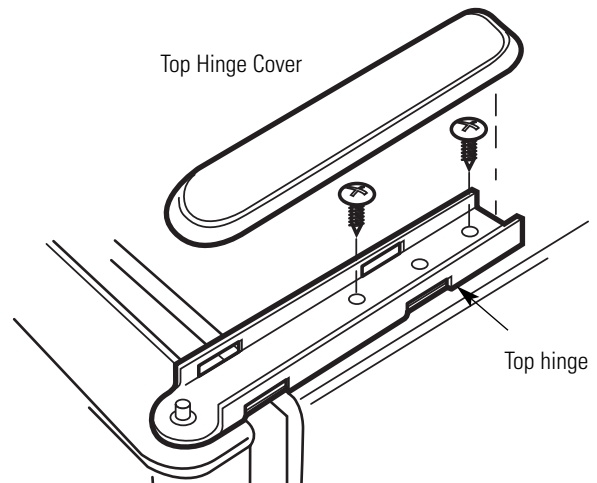

Open the freezer door slightly and lift it off.

2 REMOVE THE FRESH FOOD DOOR

Remove center hinge and washers.

Open the fresh food door slightly and lift it off the bottom hinge to remove.

Move the plug buttons from the opposite side to the holes left vacant by the hinge.

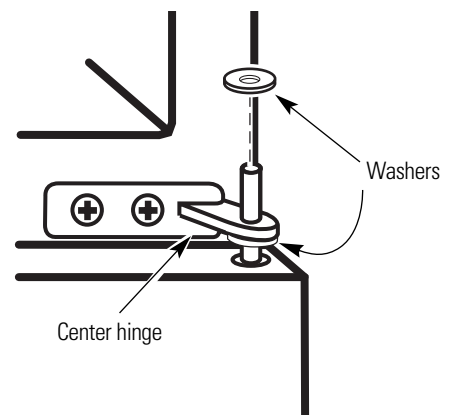

Installation Instructions

REVERSING THE DOOR SWING (CONT.)

3 MOVE THE BOTTOM HINGE

Remove the bottom hinge.

Move the plug buttons from the opposite side to the holes left vacant by the hinge.

Remove the bottom hinge pin along with the washer and put them on the other side of the hinge.

Attach the bottom hinge on the other side.

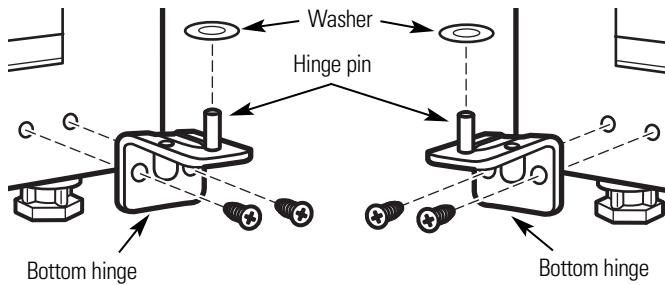

4 REHANG THE FRESH FOOD DOOR

Slide the bottom socket of the fresh food door onto the bottom hinge pin and close the door.

Slide the hinge pin into the top socket of the fresh food door and reinstall the hinge. Make sure washers are in place.

NOTE: The center hinge must be turned over as shown when mounted on the opposite side.

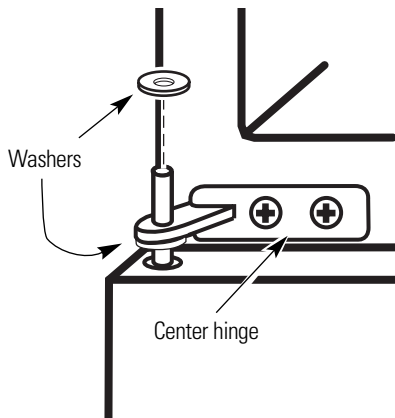

5 REHANG THE FREEZER DOOR

Lower the bottom socket of the freezer door onto the center hinge pin and close the door.

Fit the top pin into the socket at the top of the freezer door, making sure that the washer is in place on the underside of the top hinge. Tighten the screws and replace the hinge cover.

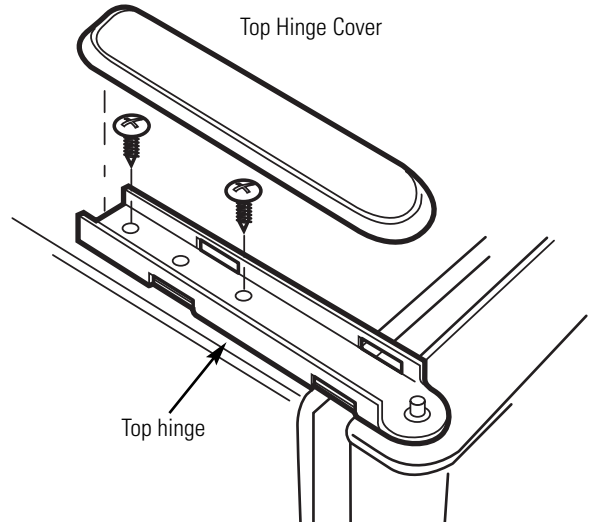

6 MOVE THE VACUUM BREAK (on some models)

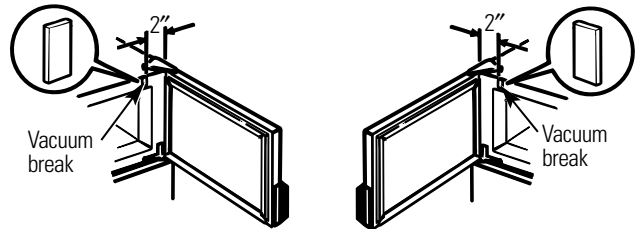

The vacuum break makes the door easier to open (Part No. WR02X8905). Carefully peel it from its original location and install it on the other side.

Apply it to the flat metal surface at the top front of the refrigerator case. It should be about 2" from the edge on the hinge side of the refrigerator.



Troubleshooting Tips
 Save time and money! Review the charts on the following pages first and you may not need to call for service.

Problem	Possible Causes	What To Do
Refrigerator does not operate	Control in OFF position.	• Move the control to a temperature setting.
	Refrigerator is unplugged.	• Push the plug completely into the outlet.
	The fuse is blown/circuit breaker is tripped.	• Replace fuse or reset the breaker.
Vibration or rattling (slight vibration is normal)	Front leveling legs need adjusting.	• See <i>Leveling Legs</i> .
Compressor operates for long periods or cycles on and off frequently. (Modern refrigerators with more storage space and a larger freezer require more operating time. They start and stop often to maintain even temperatures.)	Normal when refrigerator is first plugged in.	• Wait 24 hours for the refrigerator to completely cool down.
	Often occurs when large amounts of food are placed in refrigerator.	• This is normal.
	Door left open.	• Check to see if package is holding door open.
	Hot weather or frequent door openings.	• This is normal.
Fresh food or freezer compartment too warm	Temperature control not set cold enough.	• See <i>About the control</i> .
	Warm weather or frequent door openings.	• Set the temperature control one step colder. See <i>About the control</i> .
Frost or ice crystals on frozen food (frost within package is normal)	Door left open.	• Check to see if package is holding door open.
	Too frequent or too long door openings.	
Ice cubes have odor/taste	Food transmitting odor/taste to ice cubes.	• Wrap foods well.
	Interior of refrigerator needs cleaning.	• See <i>Care and cleaning</i> .
Slow ice cube freezing	Door left open.	• Check to see if package is holding door open.
	Temperature control not set cold enough.	• See <i>About the control</i> .
Refrigerator has odor	Foods transmitting odor to refrigerator.	• Foods with strong odors should be tightly wrapped. • Keep an open box of baking soda in the refrigerator; replace every three months.
	Interior needs cleaning.	• See <i>Care and cleaning</i> .

Before you call for service...



Troubleshooting Tips

Problem	Possible Causes	What To Do
Moisture forms on outside of refrigerator	Not unusual during periods of high humidity.	<ul style="list-style-type: none"> • Wipe surface dry.
Moisture collects inside	Too frequent or too long door openings. (In humid weather, air carries moisture into refrigerator when doors are opened.)	<ul style="list-style-type: none"> • This is normal.
Interior light does not work	No power at outlet.	<ul style="list-style-type: none"> • Replace fuse or reset the breaker.
	Lightbulb burned out.	<ul style="list-style-type: none"> • See <i>Lightbulb replacement</i>.
Ice or water is on the back wall of the refrigerator	This is normal.	<ul style="list-style-type: none"> • The back wall of the refrigerator is normally covered with drops of water or ice during operation. This is normal and part of the automatic defrosting process in the refrigerator. • The ice will melt when the compressor cycles off.
Doors are hard to open	Vacuum caused by tight seal.	<ul style="list-style-type: none"> • Wait 15 seconds between door openings. • Order vacuum break, Part No. WR02X8905.
Doors will not shut	Refrigerator not leveled properly.	<ul style="list-style-type: none"> • Adjust leveling legs to raise the front of the refrigerator. • See <i>Leveling legs</i>.

GE Service Protection Plus™

GE, a name recognized worldwide for quality and dependability, offers you Service Protection Plus™—comprehensive protection on all your appliances—**No Matter What Brand!**

Benefits Include:

- Backed by GE
- All brands covered
- Unlimited service calls
- All parts and labor costs included
- No out-of-pocket expenses
- No hidden deductibles
- One 800 number to call

***We'll Cover Any Appliance.
Anywhere. Anytime.****

You will be completely satisfied with our service protection or you may request your money back on the remaining value of your contract. No questions asked. It's that simple.

Protect your refrigerator, dishwasher, washer and dryer, range, TV, VCR and much more—**any brand!** Plus there's no extra charge for emergency service and low monthly financing is available. Even icemaker coverage and food spoilage protection is offered. You can rest easy, knowing that all your valuable household products are protected against expensive repairs.

Place your confidence in GE and call us in the U.S. toll-free at **800-626-2224** for more information.

*All brands covered, up to 20 years old, in the continental U.S.

 Cut here

Please place in envelope and mail to:

General Electric Company
Warranty Registration Department
P.O. Box 32150
Louisville, KY 40232-2150

Consumer Product Ownership Registration

Dear Customer:

Thank you for purchasing our product and thank you for placing your confidence in us.

We are proud to have you as a customer!

Follow these three steps to protect your new appliance investment:

1

Complete and mail your Consumer Product Ownership Registration today. Have the peace of mind of knowing we can contact you in the unlikely event of a safety modification.

2

After mailing the registration below, store this document in a safe place. It contains information you will need should you require service. Our service number is 800 GE CARES (800-432-2737).

3

Read your Owner's Manual carefully. It will help you operate your new appliance properly.

Model Number

Serial Number

Important: If you did not get a registration card with your product, detach and return the form below to ensure that your product is registered, or register online at www.GEAppliances.com.

Cut here

Consumer Product Ownership Registration



Model Number

Serial Number

Mr. Ms. Mrs. Miss

First Name

Last Name

Street Address

Apt. #

E-mail Address*

City

State

Zip Code

Date Placed In Use Month

Day

Year

Phone Number - -

* Please provide your e-mail address to receive, via e-mail, discounts, special offers and other important communications from GE Appliances (GEA).

Check here if you do not want to receive communications from GEA's carefully selected partners.



GE Appliances

General Electric Company
Louisville, Kentucky
www.GEAppliances.com

Refrigerator Warranty. *(For customers in the United States)*



All warranty service provided by our Factory Service Centers, or an authorized Customer Care® technician. To schedule service, on-line, 24 hours a day, contact us at www.GEAppliances.com, or call 800-GE-CARES.

Staple your receipt here.
Proof of the original purchase date is needed to obtain service under the warranty.

For The Period Of:	GE Will Replace:
One Year <i>From the date of the original purchase</i>	Any part of the refrigerator which fails due to a defect in materials or workmanship. During this full one-year warranty , GE will also provide, free of charge , all labor and in-home service to replace the defective part.
Five Years <i>From the date of the original purchase</i>	Any part of the sealed refrigerating system (the compressor, condenser, evaporator and all connecting tubing) which fails due to a defect in materials or workmanship. During this five-year warranty , GE will also provide, free of charge , all labor and in-home service to replace the defective part.

What GE Will Not Cover:

- Service trips to your home to teach you how to use the product.
- Improper installation.
- Failure of the product if it is abused, misused, or used for other than the intended purpose or used commercially.
- Loss of food due to spoilage.
- Replacement of house fuses or resetting of circuit breakers.
- Damage to the product caused by accident, fire, floods or acts of God.
- Incidental or consequential damage caused by possible defects with this appliance.

This warranty is extended to the original purchaser and any succeeding owner for products purchased for home use within the USA. In Alaska, the warranty excludes the cost of shipping or service calls to your home.

Some states do not allow the exclusion or limitation of incidental or consequential damages. This warranty gives you specific legal rights, and you may also have other rights which vary from state to state. To know what your legal rights are, consult your local or state consumer affairs office or your state's Attorney General.

Warrantor: General Electric Company. Louisville, KY 40225

Safety Instructions

Operating Instructions

Installation Instructions

Troubleshooting Tips

Consumer Support

Consumer Support.



GE Appliances Website

www.GEAppliances.com

Have a question or need assistance with your appliance? Try the GE Appliances Website 24 hours a day, any day of the year! For greater convenience and faster service, you can now download Owner's Manuals, order parts, catalogs, or even schedule service on-line. You can also "Ask Our Team of Experts™" your questions, and so much more...



Schedule Service

www.GEAppliances.com

Expert GE repair service is only one step away from your door. Get on-line and schedule your service at your convenience 24 hours any day of the year! Or call 800-GE-CARES (800-432-2737) during normal business hours.



Real Life Design Studio

www.GEAppliances.com

GE supports the Universal Design concept—products, services and environments that can be used by people of all ages, sizes and capabilities. We recognize the need to design for a wide range of physical and mental abilities and impairments. For details of GE's Universal Design applications, including kitchen design ideas for people with disabilities, check out our Website today. For the hearing impaired, please call 800-TDD-GEAC (800-833-4322).



Extended Warranties

www.GEAppliances.com

Purchase a GE extended warranty and learn about special discounts that are available while your warranty is still in effect. You can purchase it on-line anytime, or call 800-626-2224 during normal business hours. GE Consumer Home Services will still be there after your warranty expires.

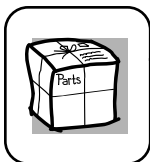

Parts and Accessories

www.GEAppliances.com

Individuals qualified to service their own appliances can have parts or accessories sent directly to their homes (VISA, MasterCard and Discover cards are accepted). Order on-line today, 24 hours every day or by phone at 800-626-2002 during normal business hours.

Instructions contained in this manual cover procedures to be performed by any user. Other servicing generally should be referred to qualified service personnel. Caution must be exercised, since improper servicing may cause unsafe operation.



Contact Us

www.GEAppliances.com

If you are not satisfied with the service you receive from GE, contact us on our Website with all the details including your phone number, or write to: General Manager, Customer Relations
GE Appliances, Appliance Park
Louisville, KY 40225



Register Your Appliance

www.GEAppliances.com

Register your new appliance on-line—at your convenience! Timely product registration will allow for enhanced communication and prompt service under the terms of your warranty, should the need arise. You may also mail in the pre-printed registration card included in the packing material, or detach and use the form in this Owner's Manual.