

HOTPOINT

HTS17BBM—Hotpoint 16.9 Cu. Ft. Top-Freezer Refrigerator

Front View

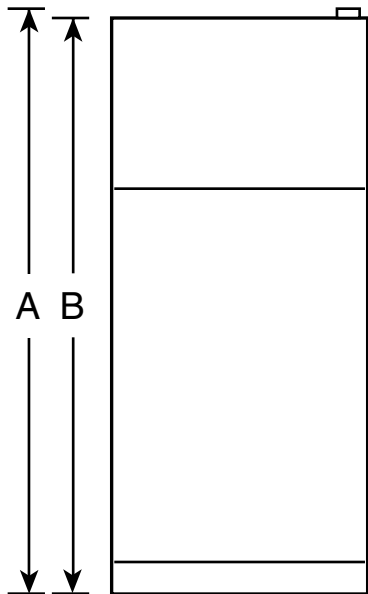

Top View

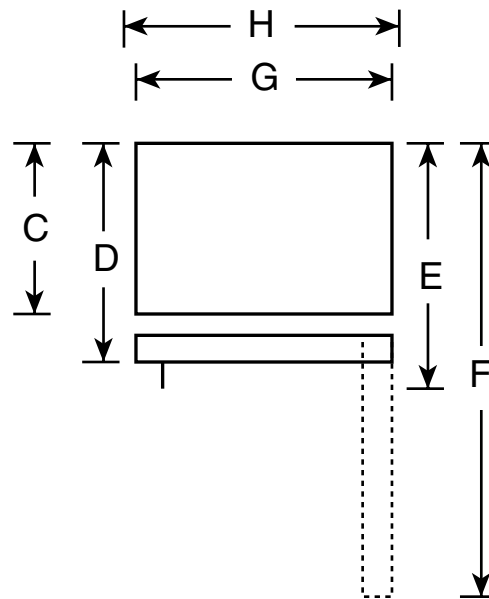

Overall Dimensions	Height with hinge (in.) A	67-3/8
	Height without hinge (in.) B	66-7/8
	Depth without Doors (in.) C	26-3/4
	Depth with Doors (in.) D	30
	Depth plus Handle with Doors Closed (in.) E	31-7/8
	Depth with Doors open 90° (in.) F	55-3/4
	Width with Doors Closed (in.) G	28
	Width with Doors open 90° Less Door Handles (in.) H	28-5/8
Air Clearances	Each side (in.)	3/4
	Top (in.)	1
	Back (in.)	1

Note: Before installing, consult installation instructions packed with product for current dimensional data.



Total volume and shelf area are calculated by the Association of Home Appliance Manufacturers' standards.



Listed by Underwriters Laboratories

HOTPOINT

HTS17BBM—Hotpoint 16.9 Cu. Ft. Top-Freezer Refrigerator

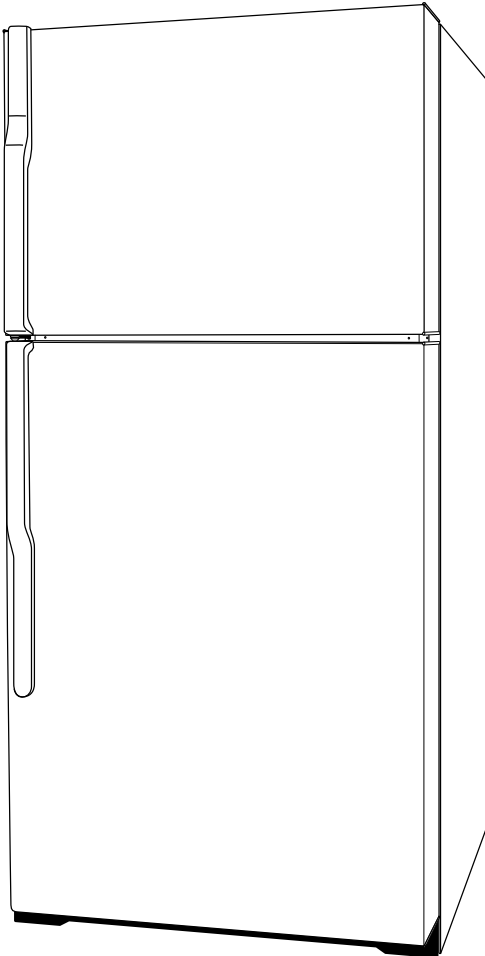

Features and Benefits

- 16.9 cu. ft. Capacity (Fresh Food 13.05 cu. ft. / Freezer 3.86 cu. ft.)
- Equipped for Optional Automatic Icemaker
- 2 Vegetable/Fruit Crispers
- 2 Adjustable Full-Width Wire Everwhite Fresh Food Cabinet Shelves
- 2 Fresh Food Door Shelves with Tall Bottle Storage
- Dairy Compartment
- 2 Fixed Freezer Door Shelves
- 2 Ice 'N Easy Trays with Ice Tray Shelf
- Deluxe Quiet Design Quiet Package
- Color-Matched Door Handles
- Model HTS17BBMWW—White on white
- Model HTS17BBMAA—Almond on almond