



# REVERSE OSMOSIS FILTRATION SYSTEM

**SAFETY INFORMATION** ..... 3

**SPECIFICATIONS**  
 Specifications and Dimensions ..... 5  
 Performance Data ..... 6-8  
 Arsenic Facts ..... 9

**USING THE REVERSE OSMOSIS SYSTEM** ..... 10

**INSTALLATION INSTRUCTIONS**  
 Tools and Materials Required ..... 12  
 Before Beginning Installation ..... 13  
 Plan the Installation ..... 14  
 Feed Water Supply ..... 15  
 Drain Adapter ..... 16  
 Storage Tank and Faucet ..... 18  
 Faucet Electronics ..... 19  
 Remineralization/Antimicrobial Filter Bracket ..... 19  
 Connect Tubes ..... 20  
 Sanitize the System ..... 22  
 Test and Purge the System ..... 23

**CARE AND CLEANING**  
 Cartridge Life and Replacement ..... 24  
 Change Faucet Battery ..... 25  
 Drain Flow Control ..... 26

**TROUBLESHOOTING TIPS** ..... 27

**PARTS LIST** ..... 28

**WARRANTY** ..... 30

**CONSUMER SUPPORT** ..... 32

## OWNER'S MANUAL & INSTALLATION INSTRUCTIONS

GXRV40TBN

ENGLISH



System tested and certified by NSF International against NSF/ANSI Standards 42 and 58 for the reduction of claims as specified in the performance data sheet, and NSF/ANSI/CAN 372



System certified by IAPMO R&T against NSF/ANSI Standards 42, 53, 58, 401, P473 & P231 for the reduction of claims as specified in the performance data sheet.

Write the model and serial numbers here:

Model # \_\_\_\_\_

Serial # \_\_\_\_\_

You can find them on the bracket.

## **THANK YOU FOR MAKING GE APPLIANCES A PART OF YOUR HOME.**

---

Whether you grew up with GE Appliances, or this is your first, we're happy to have you in the family.

We take pride in the craftsmanship, innovation and design that goes into every GE Appliances product, and we think you will too. Among other things, registration of your appliance ensures that we can deliver important product information and warranty details when you need them.

Register your GE appliance now online. Helpful websites and phone numbers are available in the Consumer Support section of this Owner's Manual. You may also mail in the pre-printed registration card included in the packing material.



**GE APPLIANCES**

# IMPORTANT SAFETY INFORMATION

## READ ALL INSTRUCTIONS BEFORE USING THE APPLIANCE

Read, understand, and follow all safety information contained in these instructions prior to installation and use of the GE Appliances Reverse Osmosis system. Retain these instructions for future reference.

Intended use:

The GE Appliances Reverse Osmosis system is intended for use in filtering potable water in Residential applications, and has not been evaluated for other uses. The system is typically installed at the point of use, and must be installed as specified in the installation instructions. Contact a plumbing professional if you are uncertain how to install.

### SAFETY PRECAUTIONS

Be sure the water supply conforms with the Specification Guidelines. If the water supply conditions are unknown, contact your municipal water company or your local health department for a list of contaminants in your area and a list of laboratories certified by your state to analyze drinking water.

#### **WARNING** To reduce the risk associated with choking:

- Do not allow children under 3 years of age to have access to small parts during the installation of this product.

#### **WARNING** To reduce the risk associated with the ingestion of contaminants:

- Do not use with water that is microbiologically unsafe or of unknown quality without adequate disinfection before or after the system. Systems certified for cyst reduction may be used on disinfected water that may contain filterable cysts.

#### **WARNING** To reduce the risk of physical injury due to hydropneumatic tank rupture:

- Do not install if water pressure exceeds 100 psi (689 kPa). If your water pressure exceeds 80 psi (552 kPa), you should install a pressure limiting valve. Contact a plumbing professional if you are uncertain how to check your water pressure.
- Do not install where water hammer conditions may occur. If water hammer conditions exist you should install a water hammer arrester. Contact a plumbing professional if you are uncertain how to check for this condition.
- Where a backflow prevention device is installed on a water system, a device for controlling pressure due to thermal expansion should be installed.

#### **WARNING** Chemical Burn Hazard:

- Keep batteries away from children. This product contains a lithium button cell battery. If a new or used lithium button cell battery is swallowed or enters the body, it can cause severe internal burns and can lead to death in as little as 2 hours. If you think batteries might have been swallowed or placed inside any part of the body, seek immediate medical attention. Always completely secure the battery compartment. If the battery compartment does not close securely, stop using the product, remove the battery and keep it away from children. Properly dispose of used batteries, keeping them away from children.

#### To reduce the risk associated with ingesting of water contaminated with sanitizer:

- After installation, sanitizer MUST be flushed from the system before first use as directed within the installation instructions.

This system has been tested for the treatment of water containing pentavalent arsenic (also known as As(V), As(+5) or arsenate) at concentrations of 0.050 mg/L or less. This system reduces pentavalent arsenic, but may not remove other forms of arsenic. This system is to be used on water supplies containing a detectable free chlorine residual or on water supplies that have been demonstrated to contain only pentavalent arsenic. Treatment with chloramine (combined chlorine) is not sufficient to ensure complete conversion of trivalent arsenic to pentavalent arsenic. Please see the Arsenic Facts section on page 9 for further information.

The compounds certified under NSF/ANSI 401 have been deemed as “incidental contaminants/emerging compounds”. Incidental contaminants are those compounds that have been detected in drinking water supplies at trace levels. While occurring at only trace levels, these compounds can affect the public acceptance/perception of drinking water quality.

## READ AND SAVE THESE INSTRUCTIONS

# IMPORTANT SAFETY INFORMATION

## READ ALL INSTRUCTIONS BEFORE USING THE APPLIANCE

### SAFETY PRECAUTIONS (continued)

This system has a lithium battery containing perchlorate. Per California Regulation: Perchlorate Material – Special handling may apply. See [www.dtsc.ca.gov/hazardouswaste/perchlorate](http://www.dtsc.ca.gov/hazardouswaste/perchlorate).

#### Extended non-use of the Reverse Osmosis system:

- If the system has not been used for one week or more, open the RO water faucet and allow the system to drain. Close the RO water faucet and allow the system to regenerate the water supply.

Recommended installation is under the sink. However, the unit can be installed in a remote location, up to 20 feet away from the sink.

- However, additional materials will be required. See parts list to obtain additional materials from GE Appliances.
- Locating the tank on a basement floor, with the faucet at a first floor sink may result in some loss of flow rate and capacity (approximately 20%). Installing a second tank will improve this performance.

If Reverse Osmosis system is connected to a refrigerator icemaker, do not use copper tubing for the connection between the Reverse Osmosis system and the refrigerator.

Sanitize upon installation of the Reverse Osmosis system and after servicing inner parts, including replacement of prefilter, postfilter and Reverse Osmosis cartridge. It is important to have clean hands while handling inner parts of the system. See the Sanitizing the System section.

This Reverse Osmosis system contains a replaceable component critical to efficiency of the system. Replacement of the reverse osmosis component should be with one of identical specifications, as defined by the manufacturer, to assure the same efficiency and contaminant reduction performance.

This Reverse Osmosis system contains a replaceable treatment component critical for effective reduction of total dissolved solids. This product water shall be tested periodically to verify that the system is performing satisfactorily. See the The Water Test Kit section.

### BE SURE TO FOLLOW ALL APPLICABLE STATE AND LOCAL CODES.

#### NOTICE: To reduce the risk associated with property damage due to water leakage:

- Read and follow these instruction before installation and use of this system.
- Installation and use MUST comply with all state and local plumbing codes.
- Protect from freezing, remove filter cartridge when temperatures are expected to drop below 40° F (4.4° C).
- Do not install systems in areas where ambient temperatures may go above 110° F (43.3° C).
- Do not install if water pressure exceeds 100 psi (689 kPa). If your water pressure exceeds 80 psi (552 kPa), you should install a pressure limiting valve. Contact a plumbing professional if you are uncertain how to check your water pressure.
- Do not install where water hammer conditions may occur. If water hammer conditions exist, you should install a water hammer arrester. Contact a plumbing professional if you are uncertain how to check for this condition.
- Where a backflow prevention device is installed on a water system, a device for controlling pressure due to thermal expansion should be installed.
- Do not use a torch or other high temperature sources near filter system, cartridges, plastic fittings or plastic plumbing.
- On plastic fittings, never use pipe sealant or pipe dope. Use PTFE thread sealing tape only, as pipe dope properties may deteriorate plastic.
- Take care when using pliers or pipe wrenches to tighten plastic fittings, as damage may occur if over tightening occurs.
- Do not install in direct sunlight or outdoors.
- Locate the system in such a position as to prevent it from being struck by other items used in the area of installation.
- Ensure that the location will support the weight of the system when installed and full of water.
- Ensure all tubing and fittings are secure and free of leaks.
- Do not install unit if any collets (parts 14 and 15 on page 29) are missing. Contact 800.952.5039 (US) if collets are missing from any fittings to obtain replacements.
- Replace the disposable prefilter and postfilter cartridges every 6 months, at the rated capacity, or sooner if a noticeable reduction in flow rate occurs.
- Replace the disposable RO cartridge every 24 months, or sooner if a noticeable reduction in filtration efficiency occurs.

## READ AND SAVE THESE INSTRUCTIONS

# Specifications

## Reverse Osmosis System Model GXRV40TBN

Supply water pressure limits	40-100 psi (280-689 kPa)
Supply water temperature limits	40-100 °F (4-38 °C)
Maximum total dissolved solids (TDS)	2000 ppm
Maximum water hardness @ 6.9 pH	10 gpg
Maximum iron, manganese, hydrogen sulfide	0
Chlorine in water supply (max. ppm)	2.0
Supply water pH limits (pH)	4-10
Product (quality) water, 24 hours <sup>1</sup>	14.76 gal. (55.9 liters)
Percent rejection of TDS, minimum (new membrane) <sup>1</sup>	86.5
Automatic shutoff control	yes
Efficiency <sup>2</sup>	10.6 %
Recovery <sup>3</sup>	21.2 %
Rated Service Flow	0.8 gpm (3.0 lpm)

This system conforms to NSF/ANSI 58 for VOC reduction. See performance data sheet for individual contaminants and reduction claims.

- <sup>1</sup> @ Feed water supply at 50 psi, 77°F, and 750 TDS. Quality water production, amount of waste water and percent rejection all vary with changes in pressure, temperature and total dissolved solids.
- <sup>2</sup> Efficiency rating means the percentage of the influent water to the system that is available to the user as reverse osmosis treated water under operating conditions that approximate typical daily usage.
- <sup>3</sup> Recovery rating means the percentage of the influent water to the membrane portion of the system that is available to the user as reverse osmosis treated water when the system is operated without a storage tank or when the storage tank is bypassed.

**Visually Contaminated Water Sources:** Do not use for the treatment of water that is visually contaminated (cloudy) or has an obvious contamination source, such as contamination by raw sewage.

**Non-potable Water Sources:** Do not attempt to use this product to make safe drinking water from non-potable water sources. Do not use the system on microbiologically unsafe water, or water of unknown quality without an adequate disinfection before or after the system. This system is certified for cyst reduction and may be used on disinfected water that may contain filterable cysts.

**Arsenic Reduction:** This system shall only be used for arsenic reduction on chlorinated water supplies containing detectable residual free chlorine at the system inlet. Water systems using an inline chlorinator should provide a one minute chlorine contact time before the reverse osmosis system.

**Nitrate/Nitrite Test Kit:** This system is supplied with a nitrate/nitrite test kit. Product water should be monitored periodically according to the instructions provided with the test kit.

**Installations In the Commonwealth of Massachusetts:** The Commonwealth of Massachusetts requires installation be performed by a licensed plumber and do not permit the use of saddle valves. Plumbing code 248-CMR of the Commonwealth of Massachusetts must be followed in these cases.

**Product Water Testing:** The Reverse Osmosis system contains a replaceable treatment component critical for the effective reduction of total dissolved solids. Product water should be tested periodically to verify that the system is performing properly.

**Replacement of the reverse osmosis component:** This reverse osmosis system contains a replaceable component critical to the efficiency of the system. Replacement of the reverse osmosis component should be with one of identical specifications, as defined by the manufacturer, to assure the same efficiency and contaminant performance.

## Dimensions:

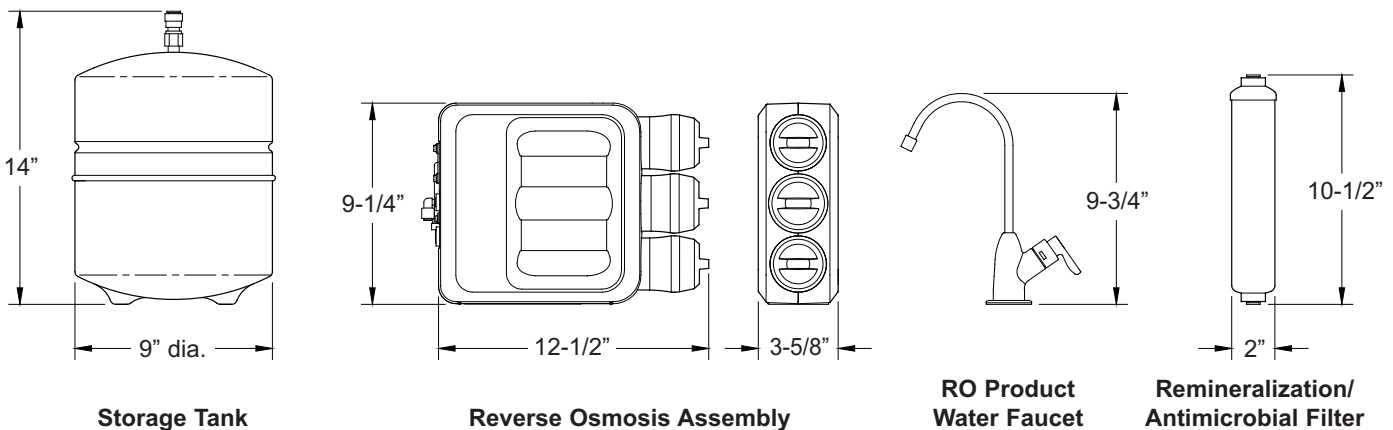

# Specifications

Performance Data for Reverse Osmosis Water Filtration System GXR40TBN						
Model	Replacement Elements	Operating Pressure Range	Operating Temperature Range	Recovery Rating	Efficiency Rating	Daily Production Rate (DPR)
GXR40TBN	FQ18MN, FQ18PN, FQ18RT	40 -100 PSI (275 - 689 kPa)	40 - 100 °F (5 - 38 °C)	21.18%	10.63%	14.76 gal./day (55.9 liters/day)
Manufactured by: GE Appliances ▪ Louisville, KY 40225 ▪ 800.952.5039 (US)						

NSF/ANSI Standard 42	Minimum Reduction	Overall % Reduction	Results
Chlorine Taste & Odor	<0.5 mg/L	97.5%	Pass

NSF/ANSI Standard 53*	Influent Challenge Concentration	Maximum Permissible Concentration	Overall % Reduction	Results
VOC Surrogate Test	300 µg/L	15 µg/L	99.8%	Pass
MTBE	15 µg/L	5 µg/L	97.8%	Pass
Perfluorooctanoic acid (PFOA) & Perfluorooctane sulfonate (PFOS)	1.5 µg/L ±10%	0.07 µg/L	97.4%	Pass

NSF/ANSI Standard 58	Influent Challenge Concentration	Maximum Permissible Concentration	Overall % Reduction	Results
Asbestos*	10 <sup>7</sup> to 10 <sup>8</sup> fibers/L	99% reduction	>99.9%	Pass
Arsenic (pentavalent)	0.30 mg/L ±10%	0.010 mg/L	98.2%	Pass
Barium	10 mg/L ±10%	2.0 mg/L	97.8%	Pass
Cadmium	0.03 mg/L ±10%	0.005 mg/L	98.1%	Pass
Chromium (VI)	0.3 mg/L ±10%	0.1 mg/L	97.0%	Pass
Chromium (III)	0.3 mg/L ±10%	0.1 mg/L	98.3%	Pass
Copper	3.0 mg/L ±10%	1.3 mg/L	98.8%	Pass
Cysts	≥50,000 particles/mL	99.95%	99.99%	Pass
Lead	0.15 mg/L ±10%	0.010 mg/L	99.1%	Pass
Fluoride	8.0 mg/L ±10%	1.5 mg/L	96.5%	Pass
Nitrate plus Nitrite (as N)	30 mg/L ±10%	10.0 mg/L	75.4%	Pass
Nitrate (as N)	27.0 mg/L ±10%	10.0 mg/L	74.9%	Pass
Nitrite (as N)	3.0 mg/L ±10%	1.0 mg/L	80.9%	Pass
Radium 226/228	25 pCi/L ±10%	5 pCi/L	80%	Pass
Selenium	0.10 mg/L ±10%	0.05 mg/L	98.0%	Pass
Turbidity	11 ±1 NTU	0.5 NTU	99.0%	Pass
TDS	750 mg/L ±40	187 mg/L	90.6%	Pass
Ammonium**	1.2 mg/L ±10%	–	90%	Pass
Bicarbonate**	300 mg/L ±10%	–	96%	Pass
Bromide**	1.5 mg/L ±10%	–	89%	Pass
Chloride**	800 mg/L ±10%	–	92%	Pass
Magnesium**	30 mg/L ±10%	–	97%	Pass
Sodium**	350 mg/L ±10%	–	88%	Pass
Sulfate**	800 mg/L ±10%	–	98%	Pass
Tannin**	3.0 mg/L ±10%	–	97%	Pass
Zinc**	15 mg/L ±10%	–	98%	Pass

\* Tested and verified by IAPMO.

\*\* Tested by Spectrum Labs, a qualified independent laboratory, against accepted industry protocol.



# Specifications

NSF/ANSI Standard 401*	Influent Challenge Concentration	Maximum Permissible Concentration	Overall % Reduction	Results
Atenolol	200 ng/L ±20%	60 ng/L	94.2%	Pass
Bisphenol A	2,000 ng/L ±20%	300 ng/L	96.3%	Pass
Carbamazepine	1,400 ng/L ±20%	200 ng/L	98.9%	Pass
DEET	1,400 ng/L ±20%	200 ng/L	95.4%	Pass
Estrone	140 ng/L ±20%	20 ng/L	90.1%	Pass
Ibuprofen	400 ng/L ±20%	60 ng/L	95.9%	Pass
Linuron	140 ng/L ±20%	20 ng/L	92.5%	Pass
Meprobamate	400 ng/L ±20%	60 ng/L	97.2%	Pass
Metolachlor	1,400 ng/L ±20%	200 ng/L	97.8%	Pass
Naproxen	140 ng/L ±20%	20 ng/L	92.0%	Pass
Nonyl phenol	1,400 ng/L ±20%	200 ng/L	97.1%	Pass
Phenytoin	200 ng/L ±20%	30 ng/L	94.2%	Pass
TCEP	5,000 ng/L ±20%	700 ng/L	96.9%	Pass
TCCP	5,000 ng/L ±20%	700 ng/L	97.8%	Pass
Trimethoprim	140 ng/L ±20%	20 ng/L	90.0%	Pass

VOCs (by surrogate testing using chloroform)*	Maximum Permissible Concentration	Effluent/ Unfiltered	Effluent/ Filtered	Percent Reduction
Alachlor	2.0 µg/L	50 µg/L	1.0 µg/L	>98%
Atrazine	3.0 µg/L	100 µg/L	3.0 µg/L	>97%
Benzene	5.0 µg/L	81 µg/L	1.0 µg/L	99%
Carbofuran	40 µg/L	190 µg/L	1.0 µg/L	>99%
Carbon Tetrachloride	5.0 µg/L	78 µg/L	1.8 µg/L	98%
Chlorobenzene	100 µg/L	77 µg/L	1.0 µg/L	99%
Chloropicrin	NA	15 µg/L	0.2 µg/L	99%
2,4-D	70 µg/L	110 µg/L	1.7 µg/L	98%
Dibromochloropropane (DBCP)	0.2 µg/L	52 µg/L	0.02 µg/L	>99%
o-Dichlorobenzene	600 µg/L	80 µg/L	1.0 µg/L	99%
p-Dichlorobenzene	75 µg/L	40 µg/L	1.0 µg/L	98%
1,2-Dichloroethane	5.0 µg/L	88 µg/L	4.8 µg/L	95%
1,1-Dichloroethylene	7.0 µg/L	83 µg/L	1.0 µg/L	99%
cis-1,2-Dichloroethylene	70 µg/L	170 µg/L	0.5 µg/L	>99%
trans-1,2-Dichloroethylene	100 µg/L	86 µg/L	1.0 µg/L	99%
1,2-Dichloropropane	5.0 µg/L	80 µg/L	1.0 µg/L	99%
cis-1,3-Dichloropropylene	NA	79 µg/L	1.0 µg/L	99%
Dinoseb	7.0 µg/L	170 µg/L	0.2 µg/L	99%
Endrin	2.0 µg/L	53 µg/L	0.59 µg/L	99%
Ethylbenzene	700 µg/L	88 µg/L	1.0 µg/L	99%
Ethyl Dibromide (EDB)	0.05 µg/L	44 µg/L	0.02 µg/L	>99%
Haloacetonitriles (HAN)				
Bromochloroacetonitrile	NA	22 µg/L	0.5 µg/L	98%
Dibromoacetonitrile	NA	24 µg/L	0.6 µg/L	98%
Dichloroacetonitrile	NA	9.6 µg/L	0.2 µg/L	98%
Trichloroacetonitrile	NA	15 µg/L	0.3 µg/L	98%

\* Tested and verified by IAPMO.

# Specifications

VOCs (by surrogate testing using chloroform)*	Maximum Permissible Concentration	Effluent/Unfiltered	Effluent/Filtered	Percent Reduction
Haloketones (HK)				
1,1-dichloro-2-propanone	NA	7.2 µg/L	0.1 µg/L	99%
1,1,1-trichloro-2-propanone	NA	8.2 µg/L	0.3 µg/L	96%
Heptachlor	0.4 µg/L	25 µg/L	0.01 µg/L	>99%
Heptachlor Epoxide	0.2 µg/L	10.7 µg/L	0.2 µg/L	98%
Hexachlorobutadiene	NA	44 µg/L	1.0 µg/L	98%
Hexachlorocyclopentadiene	50 µg/L	60 µg/L	0.002 µg/L	>99%
Lindane	0.2 µg/L	55 µg/L	0.01 µg/L	>99%
Methoxychlor	40 µg/L	50 µg/L	0.1 µg/L	>99%
Pentachlorophenol	1.0 µg/L	96 µg/L	1.0 µg/L	99%
Simazine	4.0 µg/L	120 µg/L	4.0 µg/L	97%
Styrene	100 µg/L	150 µg/L	0.5 µg/L	>99%
1,1,2,2-Tetrachloroethane	NA	81 µg/L	1.0 µg/L	99%
Tetrachloroethylene	5.0 µg/L	81 µg/L	1.0 µg/L	99%
Toluene	1,000 µg/L	78 µg/L	1.0 µg/L	99%
2,4,5-TP (silvex)	50 µg/L	270 µg/L	1.6 µg/L	99%
Tribromoacetic acid	NA	42 µg/L	1.0 µg/L	98%
1,2,4-Trichlorobenzene	70 µg/L	160 µg/L	0.5 µg/L	>99%
1,1,1-Trichloroethane	200 µg/L	84 µg/L	4.6 µg/L	95%
1,1,2-Trichloroethane	5.0 µg/L	150 µg/L	0.5 µg/L	>99%
Trichloroethylene	5.0 µg/L	180 µg/L	1.0 µg/L	>99%
Chloroform (THM)	80 µg/L	300 µg/L	15 µg/L	95%
Bromoform (THM)				
Bromodichloromethane (THM)				
Chlorodibromomethane (THM)				
Xylenes (total)	10,000 µg/L	70 µg/L	1.0 µg/L	99%

Substance	Log Reduction	% Reduction
Cyst*	3.5	99.95%
Virus*	4	99.99%
Bacteria*	6	99.9999%

Filter Performance Data	
<b>Flow Rate</b>	0.8 gallons per minute (3.03 liters per minute)
<b>Capacity</b>	240 gallons (908 liters)

This system has been tested according to NSF/ANSI standards for the reduction of substances listed above. The concentration of the indicated substances in water entering the system was reduced to a concentration less than or equal to the permissible limit for water leaving the system, as specified in NSF/ANSI Standards 42, 53, 58 and 401.

Testing was performed under standard laboratory conditions. Actual performance may vary.

Efficiency rating means the percentage of the influent water to the system that is available to the user as reverse osmosis treated water under operating conditions that approximate typical daily usage.

Recovery rating means the percentage of the influent water to the membrane portion of the system that is available to the user as reverse osmosis treated water when the system is operated without a storage tank or when the storage tank is bypassed.

Do not use with water that is microbiologically unsafe or of unknown quality, without adequate disinfection before or after the system. This system is certified for cyst reduction, and may be used on disinfected water that may contain filterable cysts.

This system is acceptable for treatment of influent concentrations of no more than 27 mg/L nitrate and 3 mg/L nitrite in combination, measured as N, and is certified for nitrate/nitrite reduction only for water supplies with a pressure of 40 psig (276 kPa) or greater.

\* Tested and verified by IAPMO.



# Specifications

This system has been tested for the treatment of water containing pentavalent arsenic [also known as As (V), As (+5), or arsenate] at concentrations of 0.30 mg/L or less. This system reduces pentavalent arsenic, but may not reduce other forms of arsenic. This system shall be used on water supplies containing a detectable free chlorine residual at the system inlet or on water supplies that have been demonstrated to contain only pentavalent arsenic. Treatment with chloramine (combined chlorine) is not sufficient to ensure complete conversion of trivalent arsenic to pentavalent arsenic. Please see the Arsenic Facts section below for further information.

## Arsenic Facts

### Background

Arsenic (abbreviated As) can occur naturally in well water. There are two forms of arsenic: pentavalent arsenic [also called As (V), As (+5), and arsenate] and trivalent arsenic [also called As (III), As (+3), and arsenite]. Although both forms are potentially harmful to human health, trivalent arsenic is considered more harmful than pentavalent arsenic. In well water, arsenic may be pentavalent, trivalent, or a combination of both. Additional information about arsenic in water can be found on the Internet at the U.S. Environmental Protection Agency (USEPA) website: [www.epa.gov/safewater/arsenic.html](http://www.epa.gov/safewater/arsenic.html).

### Testing Your Water

Arsenic in water has no color, taste or odor. It must be measured by a lab test. Public water utilities must have their water tested for arsenic. You can get the results from your water utility. If you have your own well, you can have the water tested. The local health department or the state environmental health agency can provide a list of certified labs. The cost is typically \$15 to \$30.

### Pentavalent vs. Trivalent Arsenic Removal

These systems are very effective at reducing pentavalent arsenic from drinking water. These models were tested in a lab and proven to reduce 300 parts per billion (ppb) pentavalent arsenic to below 10 ppb, the USEPA standard for safe drinking water.

RO systems are not as effective at reducing trivalent arsenic from water. These models will not convert trivalent arsenic to pentavalent arsenic. If you have free chlorine residual in contact with your water supply for at least one minute any trivalent arsenic will be converted to pentavalent arsenic and reduced by this RO. Other water treatment chemicals such as ozone, and potassium permanganate will also change trivalent arsenic to pentavalent arsenic. A combined chlorine residual (also called chloramine) may not convert all the trivalent arsenic. If you get your water from a public water utility, contact the utility to find out if free chlorine or combined chlorine is used in the water system.

### Maintenance

It is strongly recommended that you follow the maintenance instructions and have your water tested periodically to make sure the system is performing properly. See replacement element information above for recommendations on maintaining your Reverse Osmosis water filtration system.

# Using the Reverse Osmosis System

---

## How the Reverse Osmosis System Works

Reverse Osmosis reduces Total Dissolved Solids (TDS) and organic matter from water by diffusing it through a special membrane. The membrane separates minerals and impurities from the water and they are flushed to the drain. For the reduction of the claims specified, see the performance data on pages 6-8. High quality product water goes directly to the drinking water faucet or to the storage tank. The system makes a good supply of drinking water each day. How much it makes depends on the feed water supply pressure, temperature and quality.

The prefilter and postfilter are replaceable cartridges. The carbon prefilter reduces chlorine while also filtering sediments. The postfilter reduces any other undesirable tastes and odors before you use the water.

The remineralization/antimicrobial filter, which is also replaceable, adds back minerals to give the product water a more natural taste. It also contains antimicrobial media to reduce bacteria.

The system includes an electronic faucet assembly with a prefilter and postfilter change reminder. When six months have passed, a flashing light will remind you to change the two filters.

---

## Description of the Reverse Osmosis System

**Prefilter** - Water from the cold supply pipe is directed to the prefilter cartridge. The prefilter is a replaceable sediment cartridge containing activated carbon. The prefilter reduces chlorine taste and odor in the feed water because **CHLORINE DESTROYS THE REVERSE OSMOSIS MEMBRANE**. Filtered, clean, chlorine-reduced water flows from the prefilter to the Reverse Osmosis cartridge.

**Reverse Osmosis Cartridge** - The middle cartridge includes a tightly wound, special membrane. Water is forced through the cartridge where the membrane reduces the dissolved solids and organic matter. High quality product water exits the Reverse Osmosis cartridge and goes to the storage tank. Reject water, with the dissolved solids and organic matter, leaves the cartridge and is discharged to the drain through 1/4" tubing.

**Storage Tank** - The storage area holds up to 1-3/4 gallons of product water. A diaphragm inside the tank keeps water pressurized, when the tank is full, for fast flow to the faucet when drinking water is needed. When the tank is empty of water, the pressure at the air valve is 5 - 7 psi.

**Postfilter** - After leaving the storage tank, but before going to the system faucet, product water goes to the post filter cartridge. The postfilter is an enhanced replaceable sediment cartridge containing activated carbon designed to reduce select pharmaceuticals, select herbicides/pesticides, VOCs and PFOA/ PFOS as well as remaining tastes, odors, and sediments. Clean, high quality drinking water flows through the tubing to the system faucet, by way of the remineralization/antimicrobial filter

**Remineralization/Antimicrobial Filter** - After leaving the postfilter, on its way to the system faucet, product water goes to the remineralization/antimicrobial filter. The replaceable filter adds back

natural minerals present in water, replacing minerals reduced by the reverse osmosis membrane. This gives the product water a more natural taste. The cartridge also contains antimicrobial media to reduce bacteria in the water. Clean, high quality, great-tasting drinking water flows through the tubing to the system faucet.

**RO Product Water Faucet** - The countertop faucet dispenses filtered drinking water when opened. It has a variable flow handle. To comply with plumbing codes, an air gap is built into the faucet drain water connection.

**Faucet Electronics** - Inside the faucet handle is a battery operated 6 month timer. The faucet LED will light blue for a few seconds whenever the faucet handle is operated. When 90% of the filter lifetime has elapsed, the LED will flash blue 3 times whenever the faucet handle is operated. It will flash red continuously when 100% (6 months) has elapsed, to indicate that the prefilter and postfilter cartridges must be changed.

**Automatic Shutoff Assembly** - To conserve water, the drinking water system has an automatic shutoff. When the storage tank has filled to capacity and the drinking water faucet is closed, pressure closes the shutoff. Water flow to the Reverse Osmosis cartridge is shut off until drinking water is used again, and pressure drops in the Reverse Osmosis system.

**Check Valve** - The check valve in the manifold assembly prevents a backward flow of product water from the storage tank. A backward flow could cause the Reverse Osmosis membrane to rupture.

**Flow Control** - The flow control regulates the flow of water through the Reverse Osmosis cartridge at the required rate to produce high quality water. The control is located in the elbow fitting where the red 1/4" drain line exits the manifold.

# Using the Reverse Osmosis System

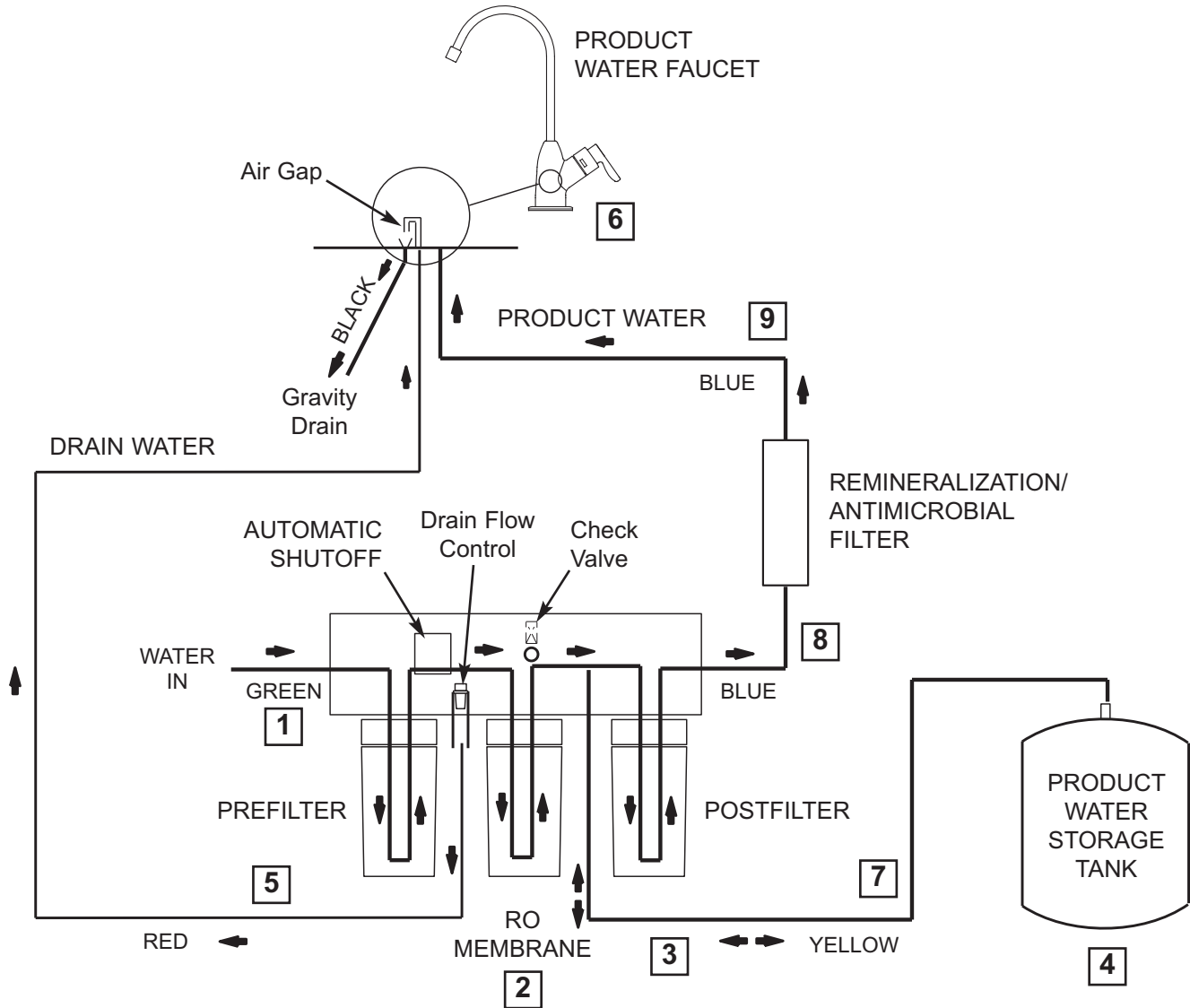

**Reverse Osmosis Water Flow Schematic**

## Water Flow Description

1. Water enters prefilter. Sand, silt and other sediments are reduced. Chlorine is also reduced.
2. Water leaves prefilter and proceeds to the Reverse Osmosis cartridge.
3. Water enters the Reverse Osmosis membrane. Dissolved solids are reduced.
4. Processed water leaves the Reverse Osmosis membrane and flows to the storage tank.
5. Drain water with dissolved solids leaves the Reverse Osmosis membrane and flows to the drain.
6. Faucet is activated.
7. Processed water leaves the storage tank and flows to the postfilter, where it is filtered to ensure fresh taste.
8. Processed water enters the remineralization/antimicrobial filter, adding back natural minerals present in water (previously reduced in the reverse osmosis process) and reducing bacteria.
9. Water flows to the Reverse Osmosis product water faucet.

# Installation Instructions

Reverse Osmosis Filtration System  
Model GXRV40TBN



Questions? Call 800.952.5039 (US)

or visit our Website at: [GEAppliances.com/ge/service-and-support/contact.htm](http://GEAppliances.com/ge/service-and-support/contact.htm)

**WARNING** Read entire manual. Failure to follow all guides and rules could cause personal injury or property damage.

- Check with your state and/or local public works department for plumbing codes. You must follow their guides as you install the Reverse Osmosis system.

**NOTE:** Failure to comply with these installation instructions will void the product warranty, and the installer will be responsible for any service, repair or damages caused thereby.

## TOOLS AND MATERIALS REQUIRED FOR INSTALLATION

- Electric Drill and 1-3/8" Drill Bit (type as required) if mounting hole is needed for faucet
- Electric Drill and 3/8" Drill Bit (type as required) if installing the included drain adapter
- Two (2) Adjustable Wrenches
- Tape Measure
- Phillips and Flat Blade Screwdrivers
- Utility Knife
- PTFE Thread Sealing Tape
- If your main water line is a rigid pipe, you will require a compression fitting and possibly other plumbing hardware to complete the installation.

**IMPORTANT:** To avoid damaging the sink, consult a qualified plumber or installer for drilling procedures. Special drill bits may be needed for stone, porcelain or stainless steel.

## BEFORE YOU BEGIN

Read these instructions completely and carefully.

- **IMPORTANT:** Save these instructions for local inspector's use.
- **IMPORTANT:** Observe all governing codes and ordinances.
- **Note to Installer:** Be sure to leave these instructions with the consumer.
- **Note to Consumer:** Keep these instructions for future reference.
- Proper installation is the responsibility of the installer.
- Product failure due to improper installation is not covered under the warranty.
- A shutoff valve must be available or added near the installation point.

## CONTENTS INCLUDED WITH SYSTEM

- Reverse Osmosis Assembly and Tubing
- Product Literature (Owner's Manual and Installation Instructions)
- Water Supply Fitting
- Faucet Assembly with Electronic Timer and Tubing
- Storage Tank
- Tank Connector
- Drain Adapter
- Remineralization/Antimicrobial Filter and Tubing
- Mounting Bracket

## Items in Parts Bags

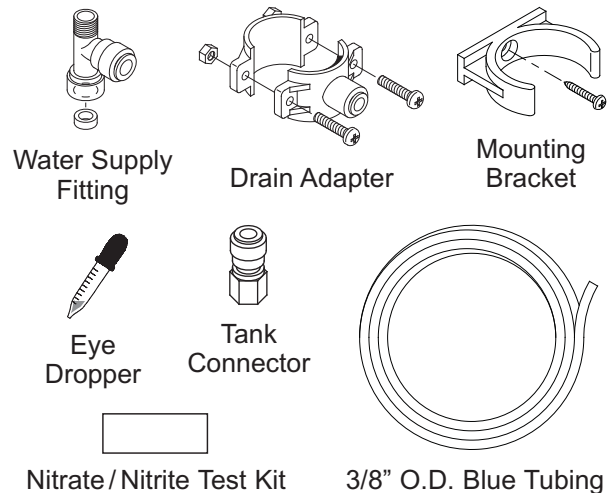

# Installation Instructions

## THINGS TO CHECK BEFORE BEGINNING INSTALLATION

### FEED WATER

The water supply to the Reverse Osmosis system must have the qualities listed in the specifications. Municipal water supplies most often will have these qualities. Well water may need conditioning; have the water tested by a water analysis laboratory and get their recommendations for treatment.

**IMPORTANT:** For water with a hardness greater than 10 grains (at 6.9 pH) the use of a softener is recommended. Failure to install a softener will reduce the life of the Reverse Osmosis cartridge.

### RO DRAIN CONNECTION

A suitable drain point and air gap (**check your state and/or local codes**) are needed for reject water from the Reverse Osmosis membrane cartridge.

### RO FAUCET

The RO product water faucet installs on the sink or on the countertop next to the sink. It may be installed in an existing sink spray attachment hole, or a hole may be drilled. Space is required underneath for tubing to and from the faucet, and for securing the faucet in place. All three faucet tubes are supplied already connected at one end to the faucet.

### BASEMENT INSTALLATION

If installing in a basement, leave enough tubing in place during installation to be able to move unit to floor for ease at servicing and making filter/membrane changes. Additional tubing and fittings required.

**NOTE:** See parts list on page 29 for optional parts that may be required for a basement installation.

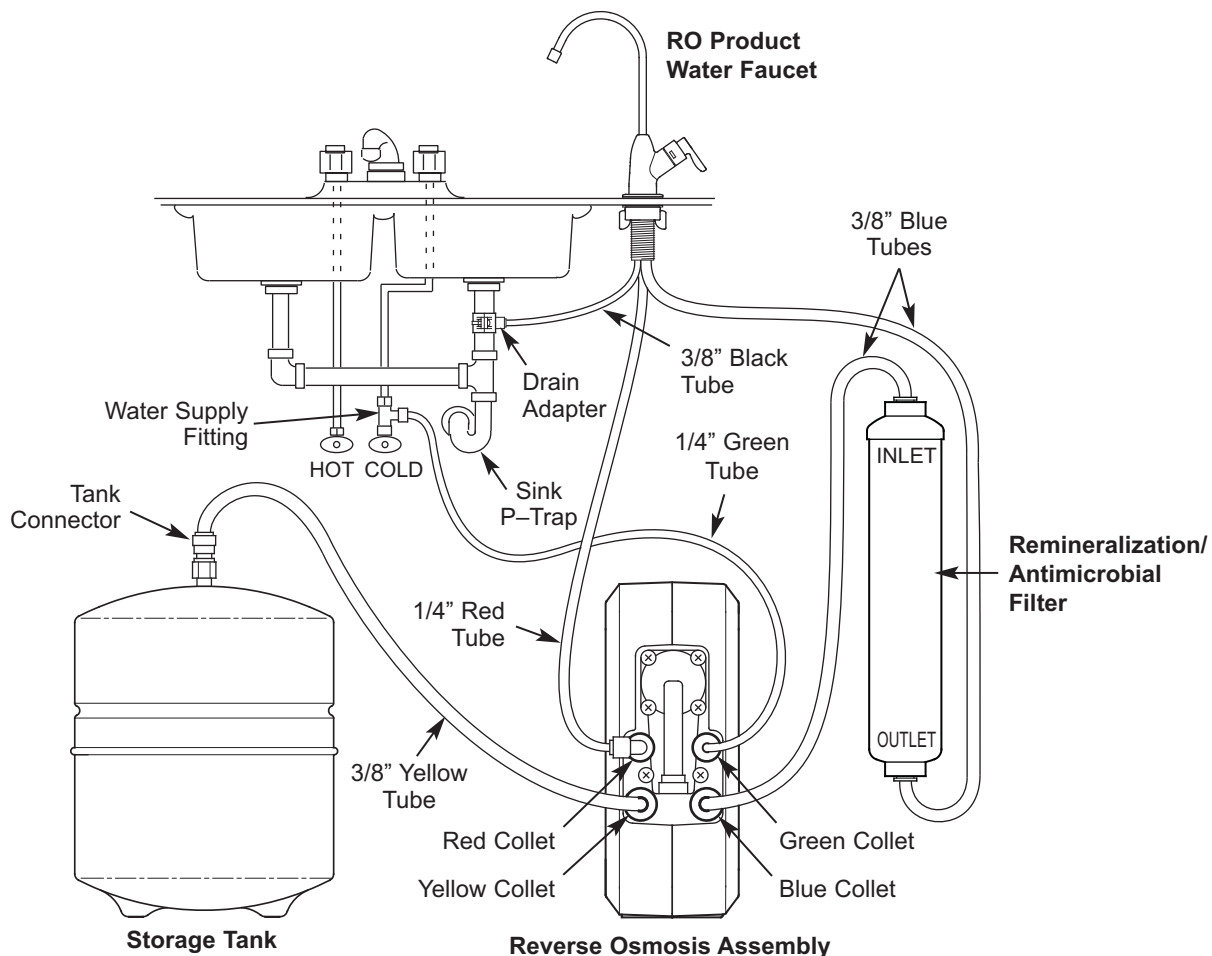

# Installation Instructions

## PLAN THE INSTALLATION

The Reverse Osmosis System can be installed under a sink or in a remote location. Typical remote sites are a laundry room or utility room. Review the location options below and determine where to install the system.

### UNDER THE SINK LOCATION

The Reverse Osmosis Filter Assembly and storage tank may be installed in a kitchen or bathroom sink cabinet.

### REMOTE INTERIOR LOCATION

The Reverse Osmosis Filter Assembly and storage tank may also be installed in a remote interior location away from the Reverse Osmosis faucet. A nearby water source and drain point are required.

### PREPARE FOR INSTALLATION

1. Before starting, close the hot and cold water shutoff valves.
2. Temporarily place tank and filter assembly into planned location. Check position of items and space required for installation. Ensure tubes may be routed without kinking.
3. Remove tank and filter from planned location and set aside.

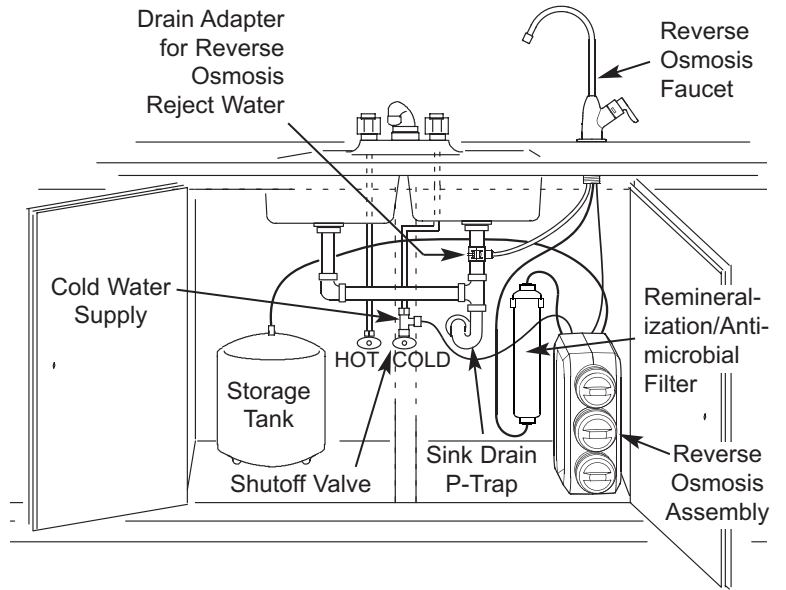

**Typical Under Sink Installation**  
Installation items included in parts bag.

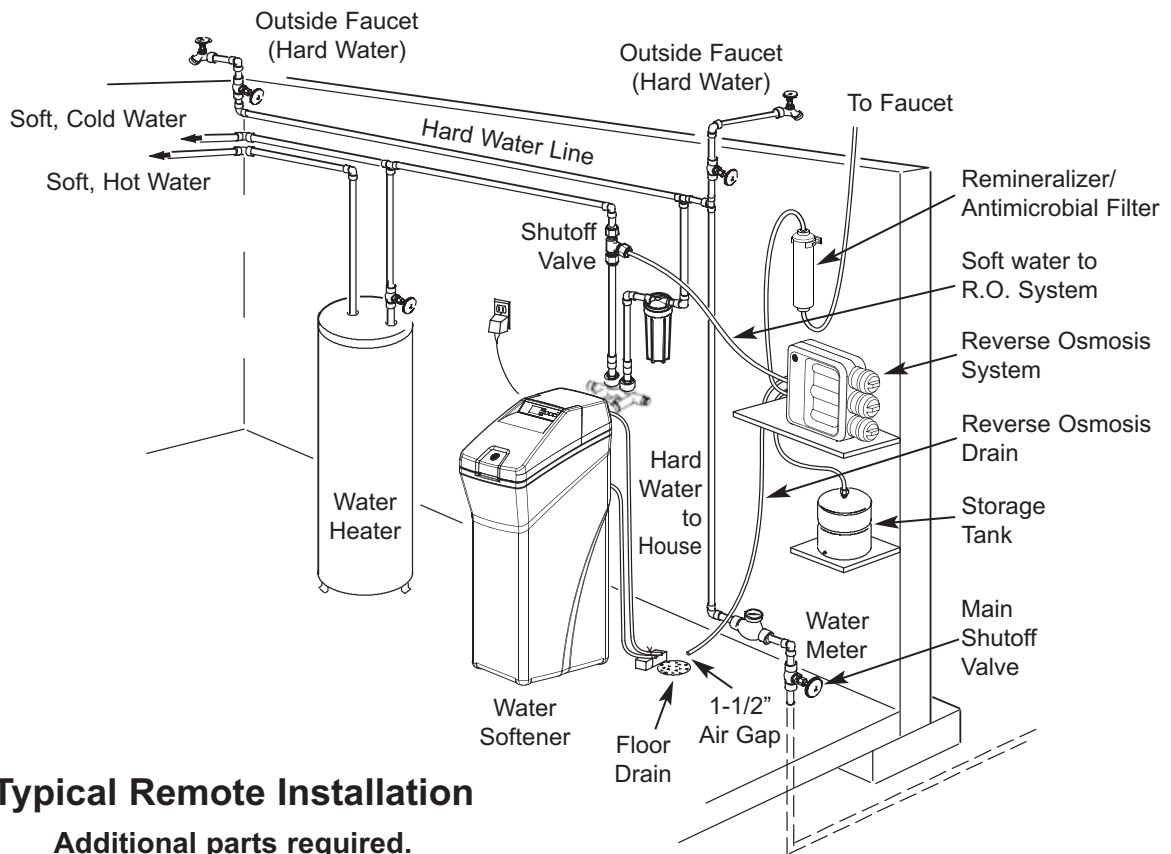

**Typical Remote Installation**  
Additional parts required.



# Installation Instructions

## FEED WATER SUPPLY

Check and comply with local plumbing codes as you plan, then install a cold water supply fitting.

### A. PREFERRED INSTALLATION

A typical connection using the included water supply fitting is shown in the illustration below.

1. Close the cold water shutoff valve and open the faucets to relieve pressure and drain water from the sink cold water pipe.

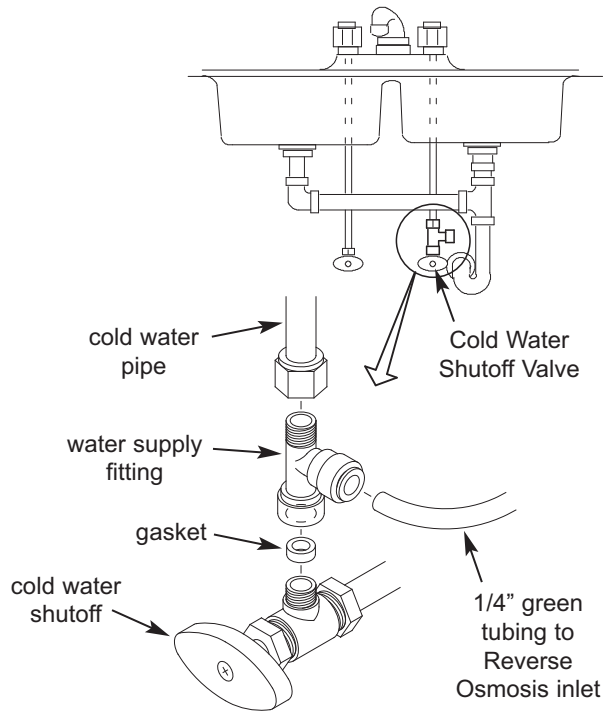

2. Disconnect the existing cold water line from the water shutoff valve.
3. Make sure that the water supply fitting's gasket is inside the female threaded portion of the fitting.
4. Install the water supply fitting onto the cold water shutoff valve, where the existing cold water line was removed, and hand tighten. Be careful not to cross thread or overtighten.
5. Connect the existing cold water line to the male threaded portion of the water supply fitting and hand tighten. Be careful not to cross thread or overtighten.

### B. OPTIONAL INSTALLATION

A typical connection using a compression type fitting (not included).

**NOTE:** Be sure to turn off the water supply and open a faucet to drain the pipe.

Complying with plumbing codes, install a fitting on the cold water pipe to adapt 1/4" OD tubing. A typical connection is shown in the illustration below.

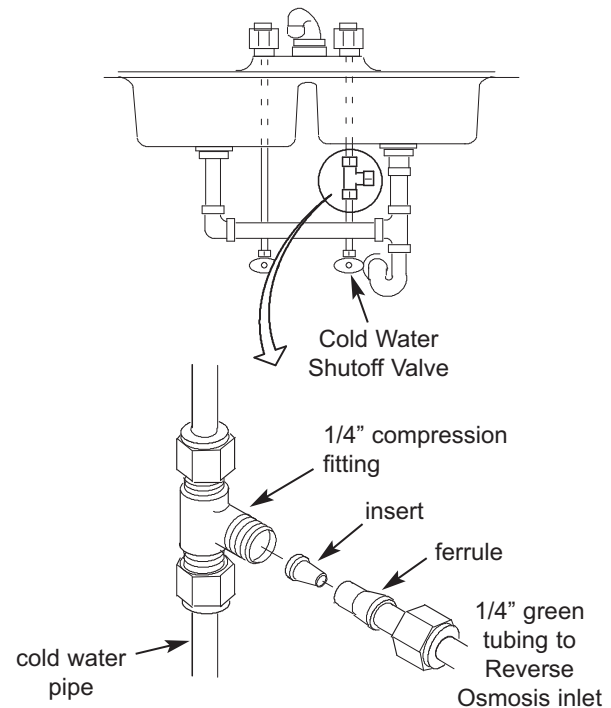

**NOTE:** If threaded fittings are used, be sure to use pipe joint compound (metal fittings only) or thread sealing tape on outside threads.

# Installation Instructions

## REVERSE OSMOSIS DRAIN ADAPTER (for under sink installation)

### INTRODUCTION

A suitable drain point is needed for the drain water from the Reverse Osmosis system. Options are:

• **Install the included Drain Adapter**

As shown below, install the included drain adapter onto the sink's drain pipe above the P-trap. This is normally used for under sink installations.

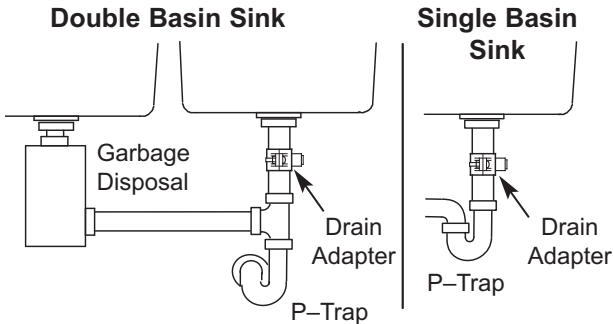

**NOTE:** Do not install drain adapter on a line coming from a garbage disposal.

• **Use another existing drain in the home**

Run the drain tube from the RO system directly to an open drain. This is often used for remote location installations.

**NOTE:** An incorrectly connected drain point can cause water to leak from the faucet's air gap.

**NOTE:** Local code may restrict the type of drain installation to use. Either drain installation type, if permitted by code, may be used in under sink or remote location installations. Consult a plumber if you are not familiar with plumbing procedures.

### INSTALL DRAIN ADAPTER

The drain adapter included with the RO system is designed to fit around a standard 1-1/2" O.D. drain pipe. In the following procedure, install the drain adapter above (upstream of) the P-trap. Be sure to comply with local plumbing codes.

**NOTE:** Before starting this procedure, inspect the drain pipe under the sink for corrosion, and replace if necessary, before continuing with installation.

1. Test fit the two halves of the drain adapter onto the sink drain pipe, about 6 inches above the P-trap. Make sure that the quick connect (Q.C.) fitting is toward the direction of the RO faucet.

**NOTE:** Locate so that the drain tubing from the Reverse Osmosis faucet will run straight to the adapter, with no dips, loops, or kinks.

### INSTALL DRAIN ADAPTER (Cont.)

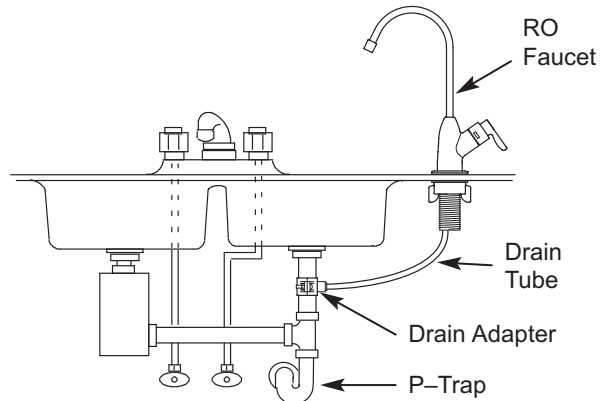

2. Using the hole through the drain fitting as a guide, mark the pipe where a 3/8" hole will be drilled, and remove the drain adapter from the pipe.

**NOTE:** Do not drill through the drain adapter's Q.C. fitting, as this could damage the o-ring.

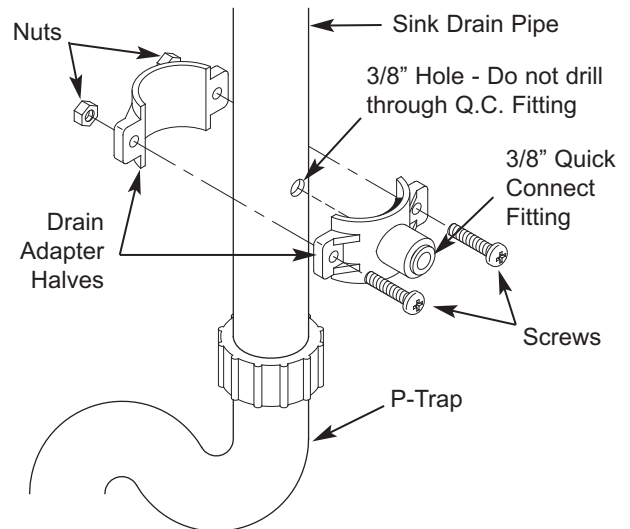

3. Drill a 3/8" dia. hole in the pipe and remove flash.
4. Clean the sink tailpiece to assure a leak-tight fit.
5. Place the halves of the drain fitting back onto the sink drain pipe. Use a pencil or similar pointed object to align the Q.C. fitting so that it is centered on the hole you drilled.
6. Assemble the nuts and screws, as shown in the illustration above, and tighten both sides equally to secure the drain adapter halves onto the pipe. Do not overtighten.
7. Do not connect black tubing to the Q.C. fitting at this time. It is done after the RO faucet is installed.

# Installation Instructions

## ALTERNATIVE DRAIN INSTALLATION (for a remote location)

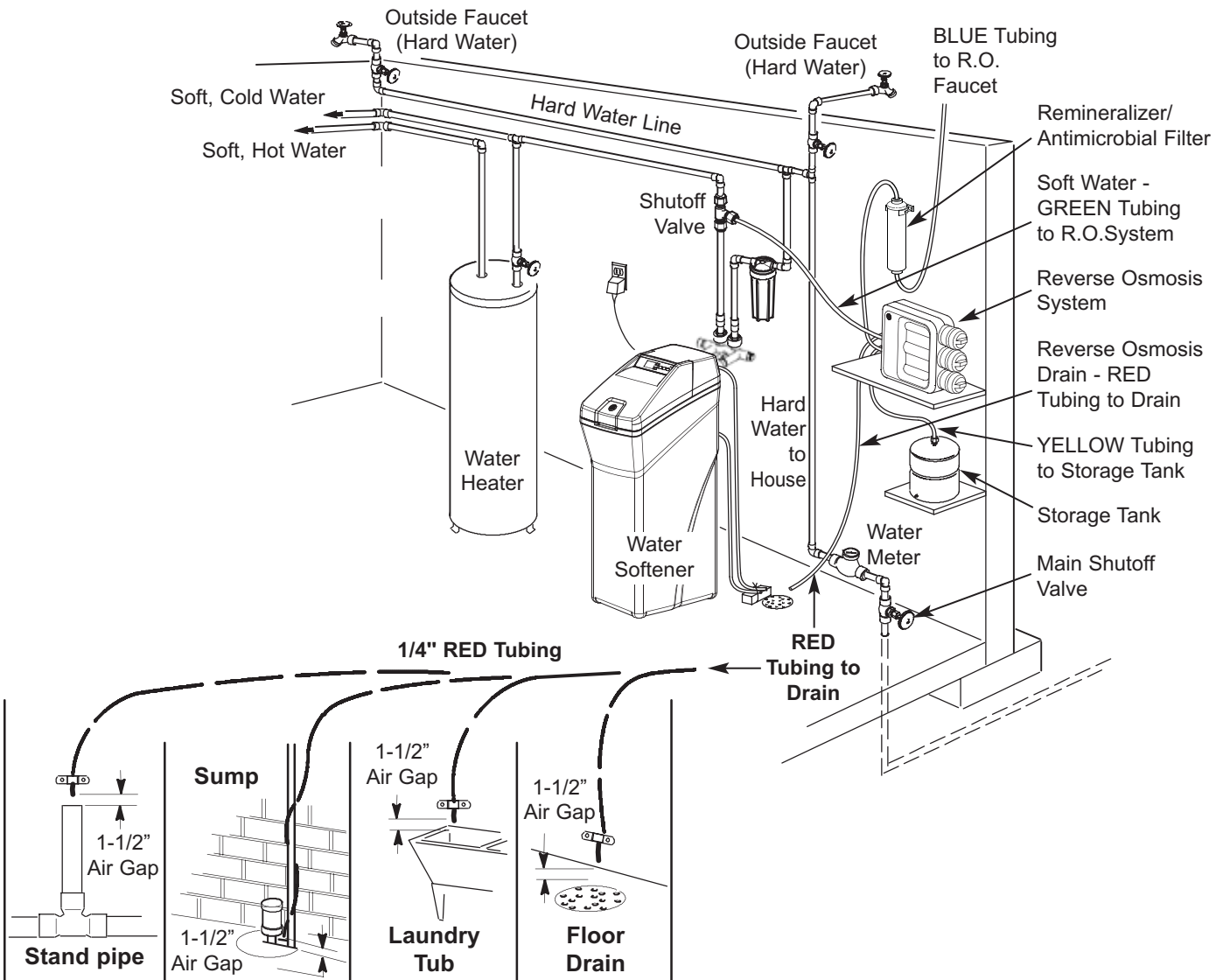

### INSTALL A DRAIN POINT AND AIR GAP (for a remote location)

Route the drain tubing to an existing drain in the house. A floor drain, laundry tub, standpipe, sump, etc. are suitable drain points. Be sure to provide a 1-1/2" air gap between the end of the hose and the drain point. This will prevent water from backing up into the system.

**NOTE:** Check your local plumbing codes.

To install a remote drain point, complete the following steps:

1. Locate the 1/4" red tube and determine whether it is long enough to reach from the Reverse Osmosis assembly to the drain point.

2. If longer tubing is required, see parts list in back of manual and replace the red tube with an adequate length of 1/4" tubing.

3. Cut one end of the drain tube square.

4. Insert this tube all the way into the red collet fitting on the Reverse Osmosis filter assembly. See illustration on page 21.

5. Pull on the tubing to be sure it is held firmly in the fitting.

**NOTE:** A flow control insert is located inside the elbow fitting that the drain tube connects to. Leave this fitting in place.

6. Route the tubing to the drain point and secure at the end with a bracket (not included). Provide a 1-1/2" air gap between the end of the tube and the drain.

# Installation Instructions

## STORAGE TANK AND FAUCET

### STORAGE TANK INSTALLATION

1. Apply thread sealing tape (2 wraps clockwise) to the threads on the nipple at the top of the tank.

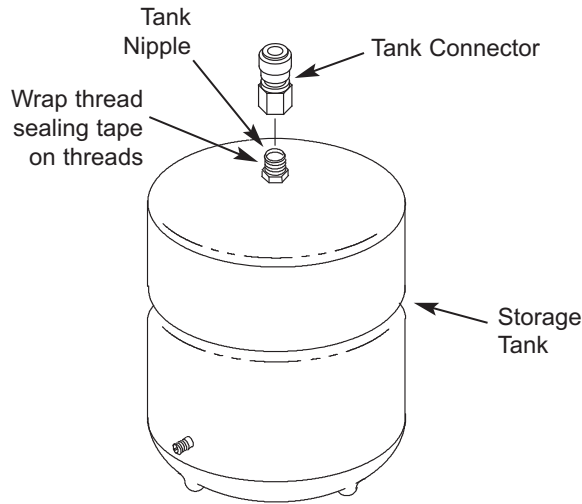

2. Locate the included tank connector. Slowly tighten the tank connector onto the tank nipple 7-8 full turns, so as not to cross thread or overtighten.
3. Do not connect the tube at this time. This will occur later in the assembly.
4. Place the storage tank next to the Reverse Osmosis assembly. The tank can be placed upright or on its side.

### INSTALL THE FAUCET

Select the location of the Reverse Osmosis product water faucet. Be sure there is room underneath and above the sink to make the needed connections. Options are:

- Use an existing sink top hole for the spray hose or soap dispenser (Must be between 1-1/4" and 1-1/2" in diameter)
- Drill a new hole in the sink top
- Drill a new hole in the countertop next to the sink

**NOTE:** Check to ensure the Reverse Osmosis faucet will mount flat against the mounting surface.

**NOTE:** Visually review the routing of the tubes from the Reverse Osmosis assembly to the faucet. Check to ensure there is adequate tube routing space between the faucet and Reverse Osmosis assembly.

### INSTALL THE FAUCET (Cont.)

1. If drilling is needed, drill a 1-3/8" diameter hole in the mounting surface. Be sure to use the proper procedure for drilling stone, porcelain or stainless steel. Special drill bits may be needed. Consult a qualified plumber.

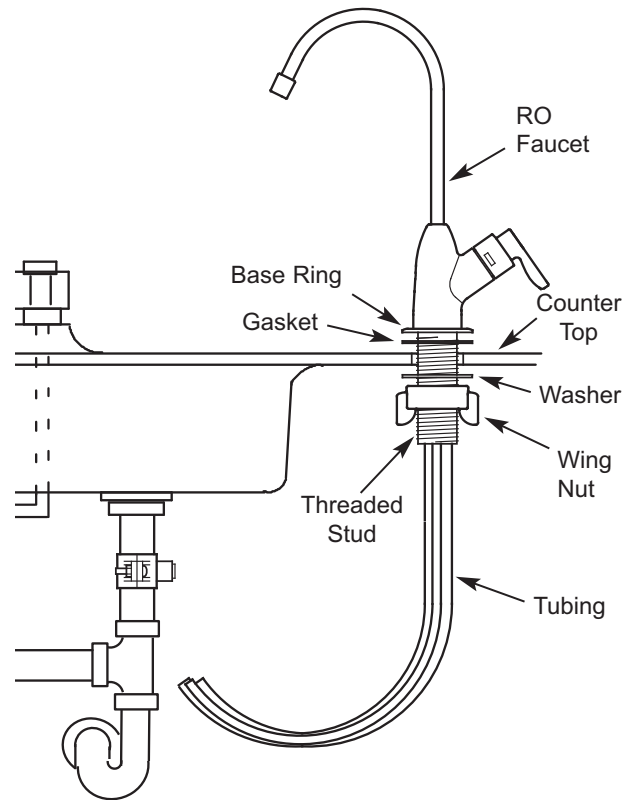

2. Unscrew the plastic wing nut from the RO faucet's threaded stud. Slide this wing nut and the adjacent metal washer off the tubing ends and set them aside to reinstall in step 4, below.

**NOTE:** Be sure the black rubber gasket and metal base ring remain in place on the faucet stud.

3. Work tubing and the faucet stud down into the mounting hole. Be sure that the faucet body seats squarely into the base ring, and that the black rubber gasket sits flat against the sink or countertop.
4. On the underside of the sink or countertop, slide the metal washer and wing nut (removed in step 2) back over the tubing ends and onto the stud. With the washer in place between the countertop and wing nut, tighten the wing nut securely.

# Installation Instructions

## FAUCET ELECTRONICS

### FAUCET ELECTRONIC TIMER

Inside the faucet handle is a battery operated 6 month timer. On a new Reverse Osmosis system, the product water faucet is shipped with a battery in the holder. After the faucet has been installed, the thin plastic strip must be removed, as shown at right, to power up the 6 month timer.

The faucet LED will light blue for a few seconds whenever the faucet handle is operated. When 90% of the filter lifetime has elapsed, the LED will flash blue 3 times whenever the faucet handle is operated. It will flash red continuously when 100% (6 months) has elapsed, to indicate that the prefilter and postfilter cartridges must be changed.

Always change the battery, as shown on page 25, when replacing the prefilter / postfilter cartridges (every 6 months).

### POWER UP THE FAUCET TIMER

1. On the faucet handle, locate the battery cover. There should be a thin plastic strip that sticks out from the battery cover.

2. Grasp the plastic strip, pull it all the way out and discard it.

3. The LED on the faucet handle will briefly flash red, then blue, to indicate the 6 month timer is powered up.

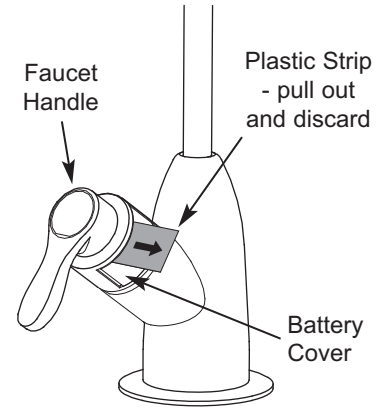

## REMINERALIZATION/ANTIMICROBIAL FILTER MOUNTING BRACKET

### MOUNT THE REMINERALIZATION/ANTIMICROBIAL FILTER

A bracket and screw are provided to mount the remineralization/antimicrobial filter to a vertical surface, such as a cabinet wall.

Before deciding where to mount the bracket, refer to the tubing connections diagram on page 21, and then consider the following:

- The filter must be oriented with the INLET end UP, as shown at right.
- Allow sufficient room beneath the filter for the tube from the outlet fitting to gently bend toward the product water faucet.
- Allow sufficient room above the filter for the tube from the inlet fitting to gently bend toward the connection on the Reverse Osmosis assembly.
- If possible, allow sufficient room above the bracket to slide the filter vertically into and out of the bracket. This is easier than snapping it in and out laterally.

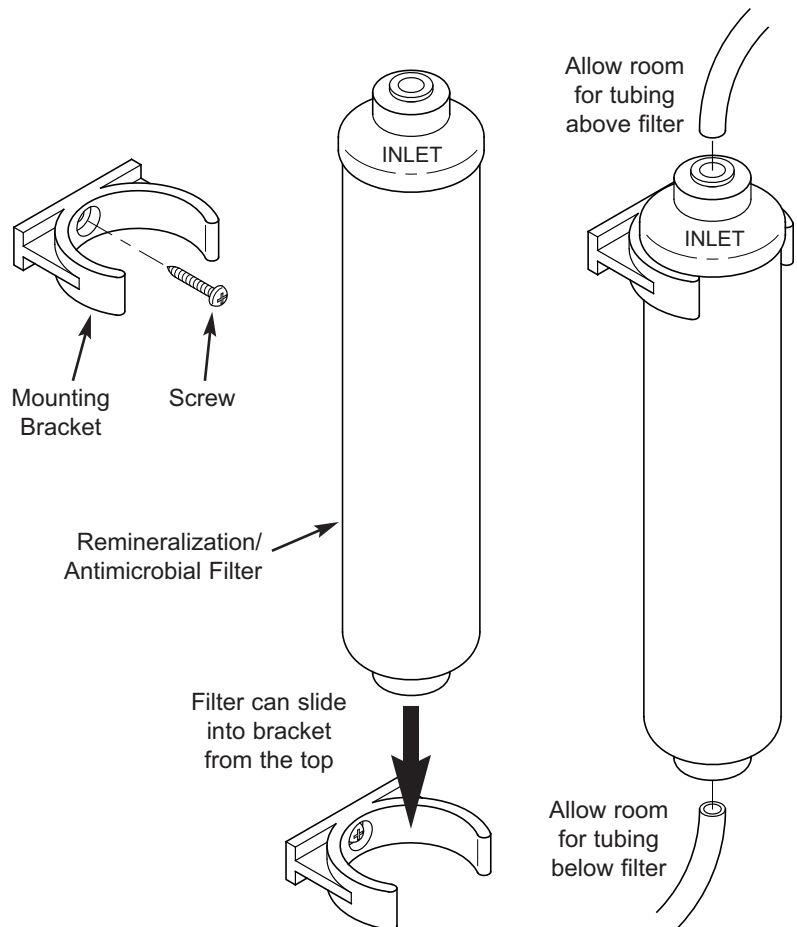

# Installation Instructions

## HOW TO CONNECT TUBES

The Reverse Osmosis system includes push-in fittings for quick tubing connection. Review the following instructions before connecting the tubes in the next step. Failure to follow these instructions may lead to future leaks.

### CUT TUBES TO LENGTH

1. Use a sharp cutter or knife to cut the end of tubing. Always cut the tubing end square and smooth, with no nicks or rough spots.

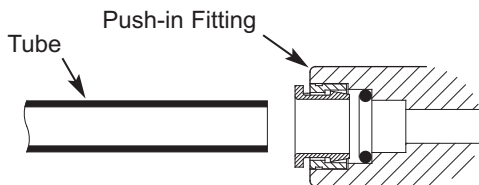

**NOTE:** Tubing lengths should allow the RO assembly to be moved for servicing.

2. Inspect the tube up to 1" from the end to be sure there are no nicks, scratches or other rough spots. If needed, cut the tubing again.

### CONNECT TUBES

1. Push tubing through collet, until it engages the o-ring. Continue pushing until the tube bottoms out against the back of the fitting. Do not stop pushing when the tube engages the o-ring. Failure to follow these instructions may lead to future leaks. When a 1/4" tube is fully engaged, 11/16" of the tube has entered the fitting. When a 3/8" tube is fully engaged, 3/4" of the tube has entered the fitting. Mark tube with a piece of tape or marker.

2. If additional tubing is required, see parts list at the end of this manual.

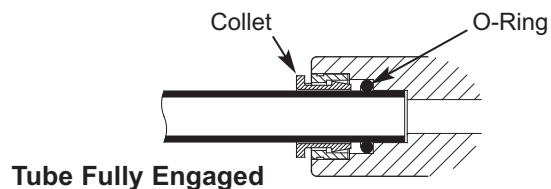
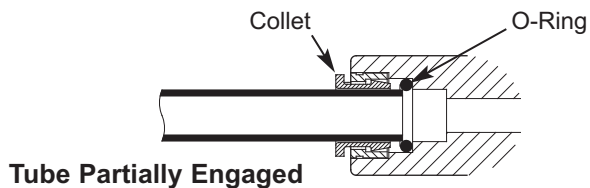

### TO DISCONNECT TUBES (If necessary)

1. Push the collet inward with a finger tip.

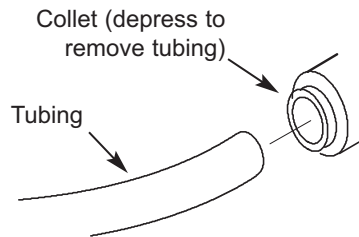

2. Continue holding collet inward while pulling the tubing out.

## MAKE TUBING CONNECTIONS

### YELLOW TUBE

from Reverse Osmosis assembly to storage tank

1. Locate the 3/8" yellow tube and cut one end square. See above.
2. Insert all the way into the yellow collet fitting on the Reverse Osmosis assembly.
3. Route the other end of this tube to the fitting on top of the storage tank.
4. Cut tube square and to length.
5. Do not connect at this time. This will occur in the sanitizing step.

### GREEN TUBE

from cold water supply pipe to Reverse Osmosis assembly

1. Locate the 1/4" green tube and cut one end square.
2. Connect to cold water supply fitting. See "Feed Water Supply" illustrations on page 15.
3. Route the other end of this tube to the green collet fitting on the Reverse Osmosis assembly.
4. Cut tube square and to length.
5. Insert all the way into the fitting.
6. Pull on the tube to be sure it is held firmly in the fitting.

### BLUE TUBE

from Reverse Osmosis faucet to Remineralization/Antimicrobial Filter

1. Locate the 3/8" blue tube attached to the faucet.
2. Route the loose end of this tube to the OUTLET



# Installation Instructions

## MAKE TUBING CONNECTIONS (Cont.)

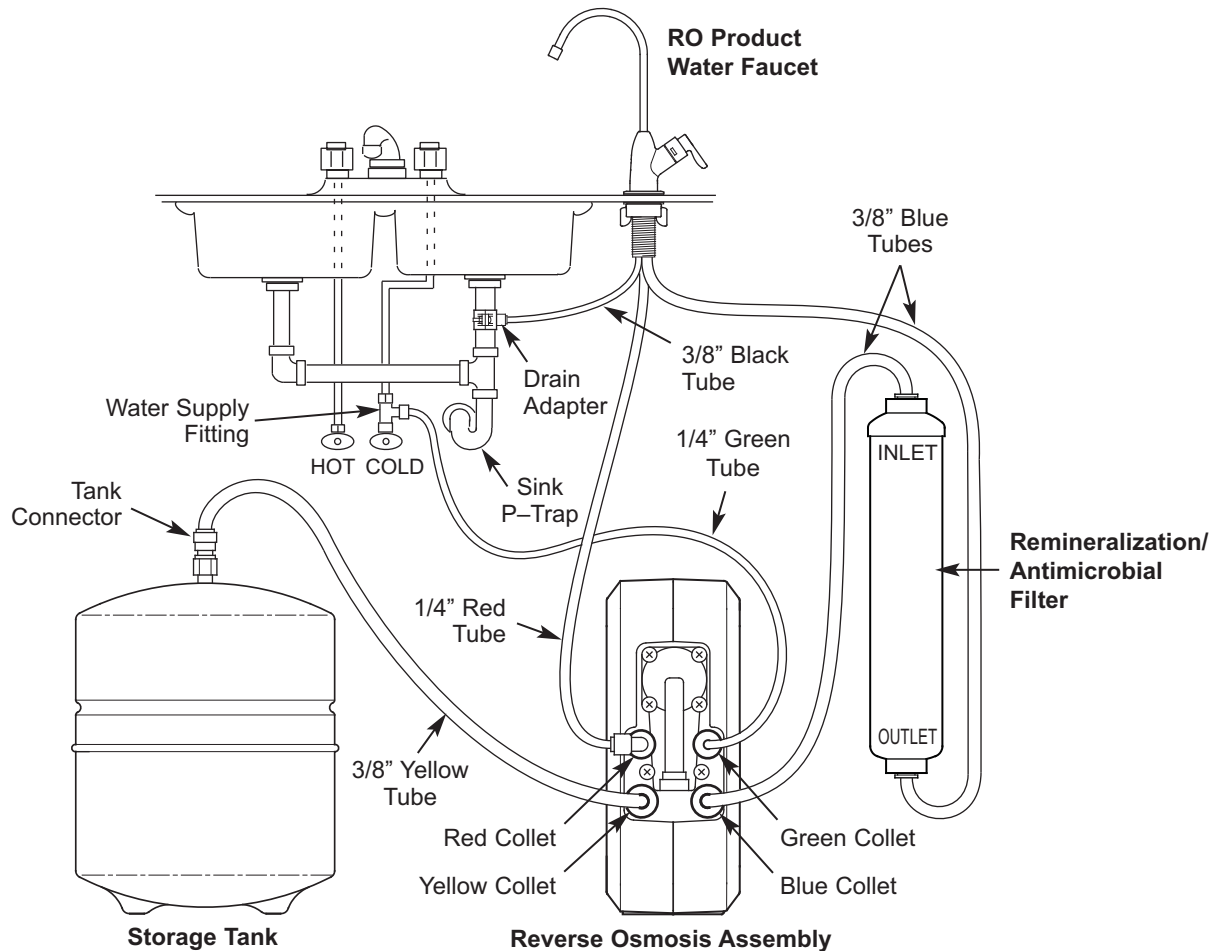

collet fitting on the Remineralization/Antimicrobial Filter.

3. Cut tube square and to length.
4. Insert all the way into the fitting.
5. Pull on the tube to be sure it is held firmly in the fitting.

### BLUE TUBE

**from Remineralization/Antimicrobial Filter to Reverse Osmosis assembly**

1. Locate the 3/8" blue tube from the parts bag and cut one end square.
2. Insert this end all the way into the INLET collet fitting on the Remineralization/Antimicrobial Filter.
3. Pull on the tube to be sure it is held firmly in the fitting.
4. Route the other end of this tube to the blue collet fitting on the Reverse Osmosis assembly.
5. Cut tube square and to length.
6. Insert all the way into the fitting.
7. Pull on the tube to be sure it is held firmly in the fitting.

### BLACK TUBE

**from Reverse Osmosis faucet to drain adapter**

1. Locate the 3/8" black tube attached to the faucet.
2. The loose end needs to be attached to the quick connect fitting on the sink drain adapter.
3. Cut this tube as needed to route it as straight as possible, without loops, dips, or kinks.
4. Cut the end of the tube square.
5. Insert all the way into the fitting.
6. Pull on the tube to be sure it is held firmly in the fitting.

### RED TUBE

**from Reverse Osmosis faucet to Reverse Osmosis assembly**

1. Locate the 1/4" red tube attached to the faucet.
2. Route the loose end of this tube to the red collet fitting on the Reverse Osmosis assembly.
3. Cut tube square and to length.
4. Insert all the way into the fitting.
5. Pull on the tube to be sure it is held firmly in the fitting.

# Installation Instructions

## SANITIZE THE SYSTEM

### SANITIZING THE SYSTEM

Sanitizing is recommended immediately after installation of the Reverse Osmosis system. It is also recommended after servicing inner parts. It is important that the person installing or servicing the system have clean hands while handling inner parts of the system.

Complete the following steps to sanitize the system.

1. Make sure that the water supply to the Reverse Osmosis system is off.
2. Open the Reverse Osmosis faucet. If the tank is not already empty, allow the water to empty.
3. Locate the included eyedropper and common household bleach (5.25%).

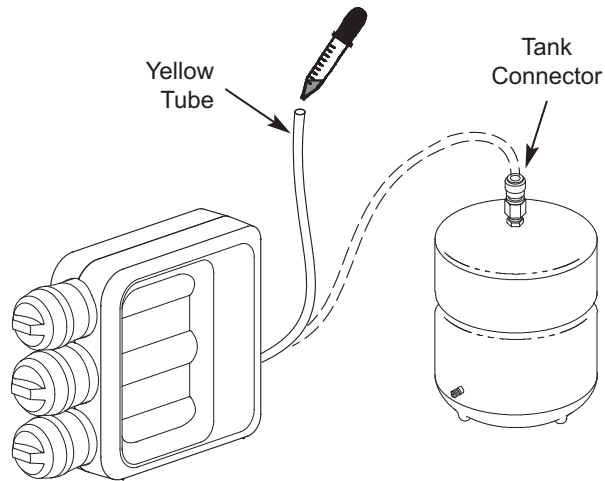

4. Add 3 ml. of bleach into open end of yellow tube. Handle bleach according to bleach manufacturer's recommendations.
5. Connect yellow tube to tank connector.
6. Sanitizing the system will be completed during the pressure test and purging steps on the following page.

**NOTE:** The bleach must be removed from the system before drinking the water. See purging instructions, following.

### OPTIONAL SANITIZING KIT

The reusable sanitizing kit (P/N WS35X22001), not included) is recommended to easily and completely sanitize the Reverse Osmosis system annually.

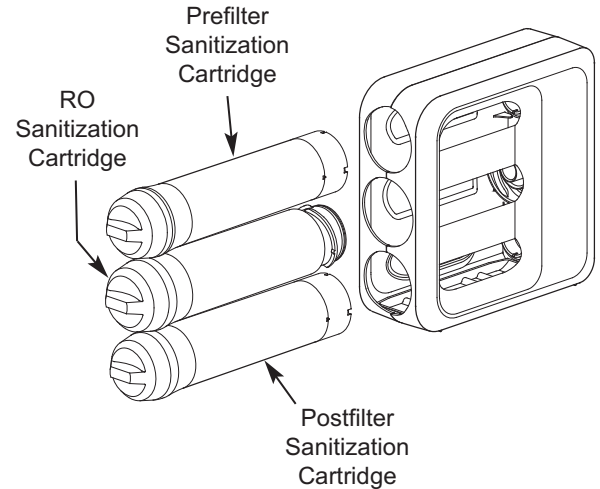

The kit includes the following:

- Prefilter sanitization cartridge (contains no filtration media)
- Postfilter sanitization cartridge (contains no filtration media)
- RO sanitization cartridge (contains no RO membrane)
- Syringe, 1 oz.
- Complete instructions

Uses standard 5.25% household bleach (not included) to completely sanitize the Reverse Osmosis system.

**To order, call toll-free GE Appliances Parts and Services at 800.952.5039 (US).**

# Installation Instructions

## TEST AND PURGE THE SYSTEM

### PRESSURE TEST THE SYSTEM

**NOTE:** Complete the sanitizing procedure on the preceding page before pressure testing.

To pressure test the system, complete the following steps.

1. Open the water supply valve to the Reverse Osmosis system (see illustration below).
2. Purge air from the house plumbing by opening several house faucets. Close faucets when water runs smooth, with no spurting.
3. Pressure will start to build in the RO system. In about 2 hours check all fittings and connections. Check for water leaks. Fix leaks if any are found. If problems exist, refer to the troubleshooting chart or call the toll free number below it.

**NOTE:** When the system is first pressurized, water may “spurt” from the faucet air gap hole until air is expelled from the RO system.

### PURGE THE SYSTEM

To purge the system, complete the following steps.

1. Open the Reverse Osmosis faucet and let water flow through the system for a 24 hour period. Water flow will be a slow trickle at this time.

**NOTE:** Do not consume water from the RO system until purging is complete.

2. Close the Reverse Osmosis faucet after the 24 hour purging period is complete.

3. When the purging is finished, your Reverse Osmosis system is ready for use.

**NOTE:** As with all other water system applications, leaks may occur. Because the system pressure builds slowly, leaks may not be immediately apparent. Recheck for leaks 24 hours after purging the system is complete.

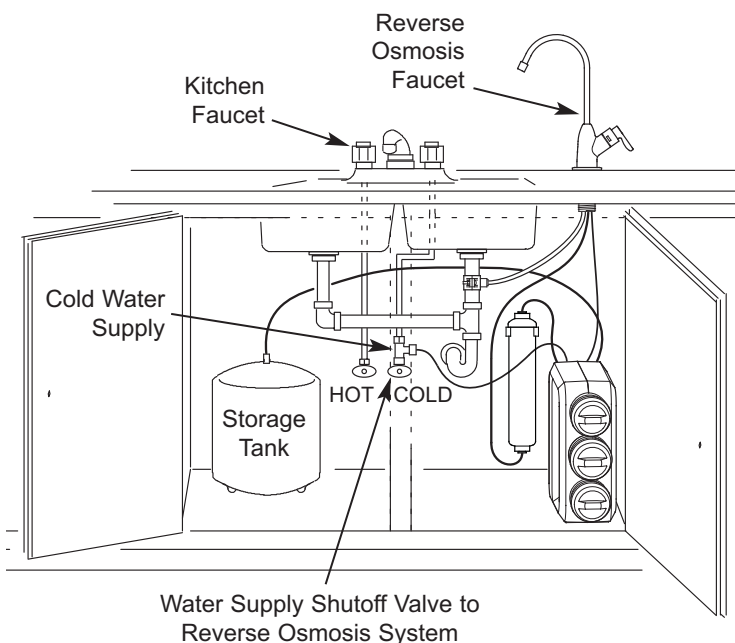

### REMOVE REMINERALIZATION MEDIA FINES

After completing the system purge described above, remove “fines” (harmless fine particles of the remineralization media) from the system. Complete the following steps to fill and empty the storage tank twice.

1. With the Reverse Osmosis faucet closed, allow the RO system to fill the storage tank. This will take about 4 hours.
2. Open the Reverse Osmosis faucet and let water flow until it slows to a trickle.
3. Close the Reverse Osmosis faucet.
4. Repeat Steps 1-3 a second time.

### OPERATING FEATURES

Please review the following operating features before using the Reverse Osmosis system:

- Filtered water will not be available immediately. It may take several hours to fill the storage tank and create maximum flow from the Reverse Osmosis faucet.
- Water Pressure from the Reverse Osmosis faucet will be less than with a standard faucet.
- Water will run to the drain while the Reverse Osmosis system is producing water, even when water is not being drawn from the Reverse Osmosis faucet. A small quantity of water may be heard trickling to the drain at times when water is not being drawn from the faucet. This is normal. Water will automatically stop going to the drain when the storage tank is full.

# Care and Cleaning

## CARTRIDGE LIFE AND REPLACEMENT

### PREFILTER / POSTFILTER CARTRIDGE LIFE

**NOTE:** It is recommended to replace the battery, prefilter and postfilter cartridges at least every 6 months of product water use. Replace more often if they begin to plug with sediment.

The prefilter and postfilter are replaceable sediment cartridges with activated carbon in their composition. The prefilter and postfilter cartridges must be periodically replaced. This will protect the RO membrane from being destroyed by chlorine. It will also prevent the filters from plugging with sediment.

Slower output of product water may be noticed as the prefilter and postfilter build up with sediment. Replace the prefilter and postfilter cartridges when this occurs. Replace the faucet battery whenever you replace the cartridges.

### PREFILTER / POSTFILTER CARTRIDGE REPLACEMENT (every 6 months)

Complete the following steps to replace the prefilter and postfilter cartridges.

1. Remove (turn counterclockwise) the prefilter cartridge from the manifold. Then remove the postfilter cartridge.
2. Discard the cartridges in a proper manner.
3. Install new cartridges in reverse order: postfilter first, then prefilter. Turn cartridges clockwise to reattach to the manifold. Do not overtighten.
4. Remove and replace the faucet timer battery. See next page for instructions.
5. Purge the Reverse Osmosis system. See previous page for instructions.

### REVERSE OSMOSIS MEMBRANE CARTRIDGE LIFE

The Reverse Osmosis cartridge is a tightly wound special membrane. The membrane reduces the dissolved solids and organic matter. The life of the Reverse Osmosis membrane cartridge depends mostly on the pH and hardness of the supply water (see Specifications). Cartridge life is shorter with higher pH. For example, if supply water pH is from 6.8 to 7.7, the cartridge may last for well over one year. However, cartridge life may be as short as 6 months if the pH is as high as 8.5 to 10. Higher pH weakens the cartridge membrane and causes pinhole leaks. It is time to replace the Reverse Osmosis cartridge when the production rate and/or quality of product water drops. Product water may begin to taste different, indicating solids and organics are passing through the Reverse Osmosis membrane. See Reverse Osmosis cartridge replacement.

### REVERSE OSMOSIS MEMBRANE CARTRIDGE REPLACEMENT

Complete the following steps to replace all cartridges when replacing the RO membrane.

1. Remove (turn counterclockwise) the prefilter cartridge from the manifold to stop flow to the Reverse Osmosis cartridge.
2. Remove the Reverse Osmosis cartridge.
3. Remove the postfilter cartridge.
4. Discard the cartridges in a proper manner.
5. Install new cartridges in reverse order: postfilter, Reverse Osmosis and then prefilter. Turn cartridges clockwise to reattach to the manifold. Do not overtighten.
6. Remove and replace the faucet timer battery. See next page for instructions.
7. Purge the Reverse Osmosis system. See previous page for instructions.

### REMINERALIZATION / ANTIMICROBIAL FILTER LIFE AND REPLACEMENT

**NOTE:** It is recommended to replace the Remineralization/Antimicrobial Filter at least every 12 months of product water use.

Complete the following steps to replace the filter:

1. Temporarily remove (turn counterclockwise) the **postfilter** cartridge from the manifold (see illustration on the following page). This stops flow to the Remineralization/Antimicrobial Filter. **DO NOT SKIP THIS STEP** or water will flow until the storage tank is empty when you disconnect tubes in Step 3.
2. Open the RO product water faucet to depressurize the old Remineralization/Antimicrobial Filter and verify that there is no flow.
3. Remove the tubes from the filter inlet and outlet by pressing down each collet and pulling the tube out.
4. Slide the filter out of the mounting bracket.
5. Discard the filter in a proper manner.
6. Slide the new Remineralization/Antimicrobial Filter into the mounting bracket, with the INLET end UP.
7. Insert the tube from the Reverse Osmosis assembly all the way into the INLET collet fitting.
8. Insert the tube from the product water faucet all the way into the OUTLET collet fitting.
9. Pull on the tubes to be sure they are held firmly in the fittings.
10. Reinstall (turn clockwise) the postfilter cartridge to resume water flow from the storage tank.
11. Purge the Reverse Osmosis system. See previous page for instructions.
12. Remove remineralization media "fines" from the system. See previous page for instructions.

To obtain replacement filters, call toll-free GE Appliances Parts and Services at 800.952.5039 (US), or visit the store where you purchased your reverse osmosis system.

Prefilter/Postfilter Cartridge Replacement FQ18PN	Carbon Block
Reverse Osmosis Cartridge Replacement FQ18MN	Thin Film Polyamide
Remineralization/Antimicrobial Filter FQ18RT	P231 Media/Minerals

# Care and Cleaning

## CARTRIDGE REPLACEMENT (Cont.)

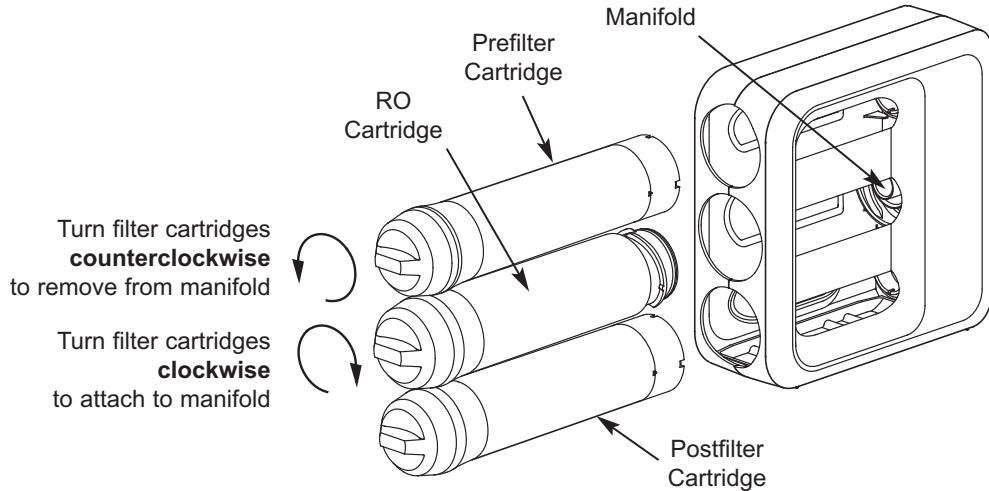

## CHANGE FAUCET BATTERY

### **WARNING** Chemical Burn Hazard:

- Keep batteries away from children. This product contains a lithium button cell battery. If a new or used lithium button cell battery is swallowed or enters the body, it can cause severe internal burns and can lead to death in as little as 2 hours. If you think batteries might have been swallowed or placed inside any part of the body, seek immediate medical attention. Always completely secure the battery compartment. If the battery compartment does not close securely, stop using the product, remove the battery and keep it away from children. Properly dispose of used batteries, keeping them away from children.

A new battery is included with the replacement prefilter /postfilter cartridge kit. Always change the battery, as shown below, when replacing the prefilter/postfilter cartridges (every 6 months).

1. Locate the battery holder cover on the RO product water faucet's handle.

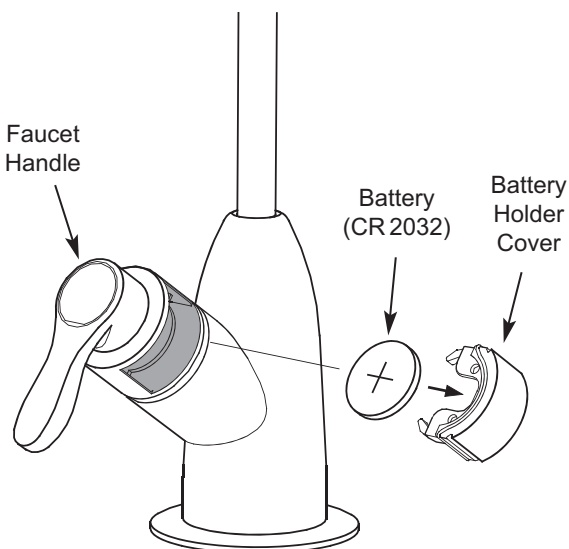

2. Grip the cover by the gaps at each side, and firmly pull it all the way out of the faucet. A screwdriver may be used to pry up the cover, but be careful not to scratch or nick the finish.
3. Pull the old battery out of the holder and replace it with the new battery from the replacement prefilter / postfilter cartridge kit (Lithium CR2032 button battery or equivalent). Place battery into the holder with the positive (+) side facing up, or away from the faucet's base.
4. Slide the battery holder back into the opening in the faucet's handle, making sure it is oriented correctly (it will not fit if upside-down). Push it all the way in until the cover is flush.
5. When the battery is installed, the faucet LED will briefly flash red then blue. The timer begins its 6 month countdown. Whenever the faucet handle is operated, the blue LED will light for a few seconds. The LED will not light if the battery was placed into the holder upside-down.



# Care and Cleaning

## THE WATER TEST KIT

To obtain an independent laboratory water test kit, please call IAS Labs at 1.602.273.7248 and leave your contact details. They will contact you to find out what water tests you are interested in, and inform you of the cost of the testing. You will then receive a kit that will include all necessary tests to properly indicate the performance level of your system. Product water should be tested a minimum of every six months.

**NOTE:** When the TDS reduction of the system falls below 75%, it is time to replace the reverse osmosis cartridge in addition to the prefilter and postfilter.

## DRAIN FLOW CONTROL

The flow control is required for proper operation of the Reverse Osmosis system. See illustration below. The flow control, located inside the push-in elbow fitting on the drain port of the Reverse Osmosis assembly, keeps water flowing through the membrane at the required rate. This ensures that the system produces the best quality product water.

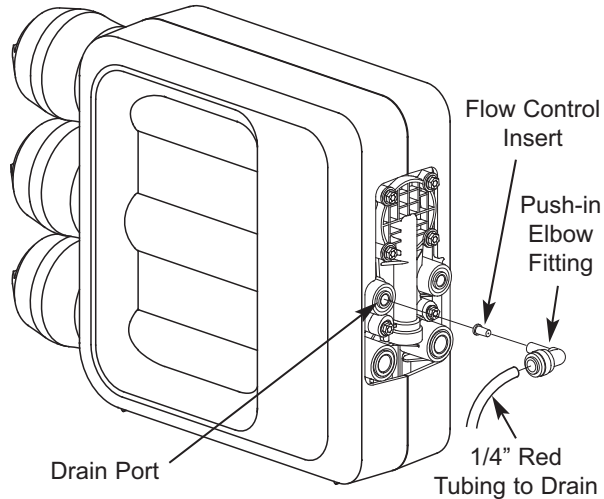

Periodically check the flow control to be sure the small hole through it is clean and unrestricted.

If the flow control requires service, review the exploded view above. Assemble and disassemble as shown. If the flow control remains in the manifold when the push-in elbow fitting is removed, it will be necessary to remove the drain port's collet and o-ring, as shown in the next section, to retrieve it.

## ASSEMBLING COLLET AND O-RING

1. Remove the collet and o-ring from the fitting with a small screwdriver. Do not scratch the internal walls of the fitting port.
2. Clean collet port, lubricate with silicone-based lubricant, and insert the o-ring seal into the bottom of the port.

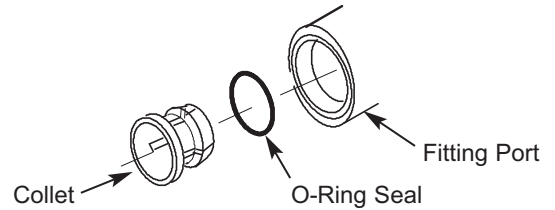

3. Push the collet inward until it locks in place.



# Troubleshooting Tips... Before you call for service

Save time and money! Review the following chart first and you may not need to call for service.

Problem	Possible Causes	What To Do
Water has air bubbles and is cloudy	Air in system after installation.	Will go away after it runs for a while.
Indicator light on faucet handle not working	Battery installed incorrectly.	Observe orientation on page 25 and install correctly.
	Battery is dead.	Replace with new Lithium CR2032, 3-volt battery.
Chlorine taste and/or odor in the Reverse Osmosis product water	The ppm of chlorine in your water supply exceeds maximum limits and has destroyed the Reverse Osmosis membrane.	If the water supply contains more than 2.0 ppm of chlorine, additional filtering of the water supply to the Reverse Osmosis is needed. Correct this condition before doing maintenance on the Reverse Osmosis system.
	The prefilter is no longer reducing chlorine from the water supply.	Replace the Reverse Osmosis membrane cartridge, prefilter, postfilter and battery in the faucet handle.
Other taste and/or odor	High quality product water may have a different taste than what you're used to.	This is normal.
	Low water usage.	Completely drain system and allow to refill.
	Contamination in product water storage.	Use sanitizing procedure.
	Prefilter and postfilter need to be changed.	Replace the prefilter and postfilter. Sanitize system.
Water leaking from faucet air gap hole	Drain side of faucet air gap (3/8" tubing) plugged, restricted or incorrectly connected to the drain.	Inspect and eliminate restriction or plug. It is important that there are no dips, loops or low spots in the drain line from the faucet air gap to the drain pipe. Refer to Installation Instructions for proper drain connection. If drain line adapter was used as the drain point, periodic inspection/cleaning is recommended.
System makes product water slowly	This is normal.	Water flow rate will be lower than a regular faucet. It takes several hours to fill the tank.
	Water supply to the Reverse Osmosis system not within specifications.	Increase water pressure, precondition the water, etc., as needed to conform before doing maintenance on the Reverse Osmosis system.
	Prefilter cartridge plugged with sediments.	Replace the prefilter. If rate does not increase, replace the postfilter, Reverse Osmosis membrane cartridge and battery in the faucet handle.
	Reverse Osmosis membrane plugged with sediments.	Replace Reverse Osmosis membrane cartridge and battery in the faucet handle.
No water	Water supply valve not turned on.	Turn water supply valve on. See illustration on page 23.
	After filter change, tank is empty.	It takes several hours for RO system to provide enough water to fill the tank.
Leaks at fittings	Improperly installed.	Reinstall. See Installation Instructions.
Sounds you may hear	Sink drain, drain water from system.	This is normal.
		Drain line can be installed to an alternate drain, such as a basement drain. See page 17 for alternate drain configurations.
	Faucet air gap drain water flowing through the faucet air gap. This may be associated with high pressure water supply, generally 80 psi or greater.	Install a pressure regulator in the house water supply system to reduce the pressure below 80 psi.

If you are still having trouble, please visit [www.GEAppliances.com/ge/service-and-support/contact.htm](http://www.GEAppliances.com/ge/service-and-support/contact.htm) or call us at 800.952.5039 (US).

GXRV40TBN

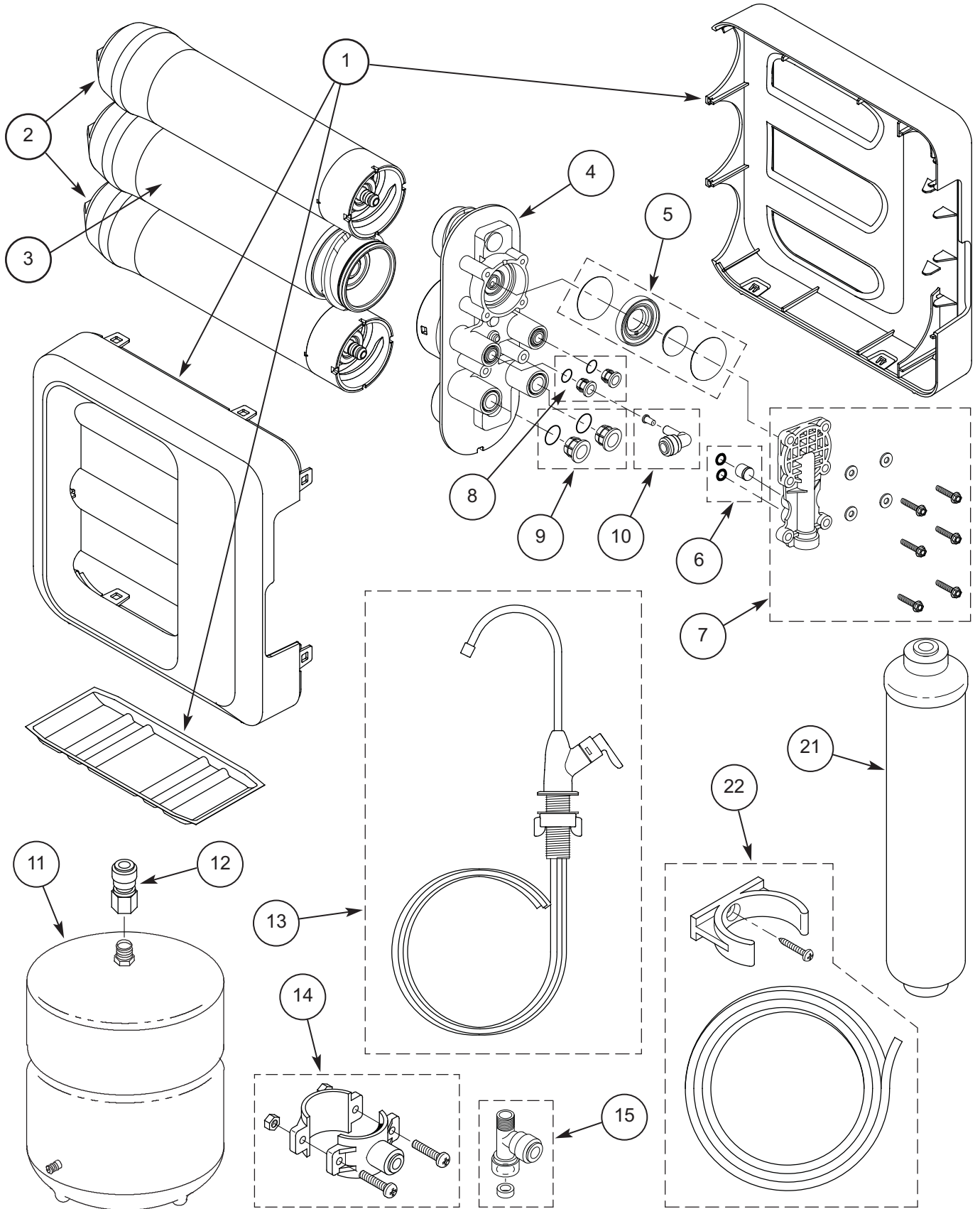

# Parts Catalog

## GXRV40TBN

REF. NO.	GE APPLIANCES PART NO.	PART DESCRIPTION	QUANTITY
0001	WS19X21938	CABINET ASSEMBLY, LEFT HALF, RIGHT HALF, AND DRIP TRAY	1
0002	FQ18PN	PRE AND POST FILTER CARTRIDGE SET, INCLUDING BATTERY (NOT SHOWN)	1
0003	FQ18MN	RO CARTRIDGE	1
0004	WS19X21937	MANIFOLD ASSEMBLY (INCLUDES REF. NO. 0001 AND 0005 THRU 0009)	1
0005	WS03X21933	DIAPHRAGM KIT	1
0006	WS15X21935	CHECK VALVE KIT	1
0007	WS15X21932	AUTOMATIC SHUTOFF KIT	1
0008	WS15X21988	COLLET KIT, 1/4" (SET OF 2)	1
0009	WS15X21989	COLLET KIT, 3/8" (SET OF 2)	1
0010	WS02X21934	FLOW CONTROL KIT	1
0011	WS32X10012	STORAGE TANK	1
0012	WS22X21939	TANK CONNECTOR	1
0013	WS15X21941	FAUCET	1
0014	WS18X21940	DRAIN ADAPTER	1
0015	WS18X21936	WATER SUPPLY FITTING	1
0016	WS35X22001	SANITIZATION KIT (OPTIONAL - SEE SANITIZING INSTRUCTIONS FOR ILLUSTRATION)	1
0017	WS35X22002	AUXILIARY STORAGE TANK (OPTIONAL - INCLUDES REF. NO. 0011 AND FITTINGS TO PLUMB IN PARALLEL WITH ORIGINAL TANK)	1
0018	WS07X10006	TUBING, 1/4" O.D. X 20 FEET LONG, WHITE (OPTIONAL FOR REMOTE INSTALLATION)	1
0019	WS07X10008	TUBING, 3/8" O.D. X 20 FEET LONG, WHITE (OPTIONAL FOR REMOTE INSTALLATION)	1
0020	WS01X22003	DROPPER	1
0021	FQ18RT	REMINERALIZATION/ANTIMICROBIAL FILTER	1
0022	WS35X23721	REMINERALIZATION INSTALLATION KIT - INCLUDES MOUNTING BRACKET, SCREW AND TUBING, 3/8" O.D. X 3 FEET LONG, BLUE	1
0999	Manual Online	OWNER'S MANUAL & INSTALLATION INSTRUCTIONS	1

# GE Appliances Reverse Osmosis System Warranty

## GEAppliances.com

All warranty service provided by our SmartWater™ Authorized Servicer Network. To schedule service, contact us toll free at 800.GE.CARES. Please have serial number and model number available when calling for service.

<b>For the period of</b>	<b>GE Appliances will replace</b>
<b>One year</b> from the date of the original purchase	<b>Any part</b> of the Reverse Osmosis Filtration System which fails due to a defect in materials or workmanship.

### What GE Appliances will not cover

- Service trips to your home to teach you how to use the product.
- Improper installation, delivery, or maintenance.
- Failure of the product if it is abused, misused, modified, or used for other than the intended purpose or used commercially.
- Use of this product where water is microbiologically unsafe or of unknown quality, without adequate disinfection. Systems certified for cyst reduction may be used on disinfected water that may contain filterable cysts.
- Filter cartridges, membrane cartridges and batteries after 30 days from date of purchase.
- Damage to the product caused by accident, fire, floods or acts of God.
- Incidental or consequential damage caused by possible defects with this appliance.

### EXCLUSION OF IMPLIED WARRANTIES

Your sole and exclusive remedy is product repair as provided in this Limited Warranty. Any implied warranties, including the implied warranties of merchantability or fitness for a particular purpose, are limited to one year or the shortest period allowed by law.

This warranty is extended to the original purchaser and any succeeding owner for products purchased for home use within the USA. If the product is located in an area where service by a GE Appliances Authorized Servicer is not available, you may be responsible for a trip charge or you may be required to bring the product to an Authorized GE Appliances Service location for service. In Alaska, the warranty excludes the cost of shipping or service calls to your home.

Some states do not allow the exclusion or limitation of incidental or consequential damages. This warranty gives you specific legal rights, and you may also have other rights which vary from state to state. To know what your legal rights are, consult your local or state consumer affairs office or your state's Attorney General.

**Warrantor: GE Appliances**

Staple your receipt here. Proof of the original purchase date is needed to obtain service under the warranty.



## For IOWA Only

All sales in Iowa require the following signature before consummation of sale. These signatures must be retained by seller/renter for 2 years minimum.

Buyer/Renter \_\_\_\_\_ Date \_\_\_\_\_

Seller \_\_\_\_\_ Date \_\_\_\_\_

Seller's Address \_\_\_\_\_

Seller's Phone No. \_\_\_\_\_

**Product: GE Appliances Reverse Osmosis Water Filtration System: Models GXRV40TBN**

# Consumer Support

---

## GE Appliances Website

Have a question or need assistance with your appliance? Try the GE Appliances Website 24 hours a day, any day of the year! You can also shop for more great GE Appliances products and take advantage of all our on-line support services designed for your convenience. In the US: [GEAppliances.com](http://GEAppliances.com)

---

## Register Your Appliance

Register your new appliance online at your convenience! Timely product registration will allow for enhanced communication and prompt service under the terms of your warranty, should the need arise. You may also mail in the pre-printed registration card included in the packing material. In the US: [GEAppliances.com/register](http://GEAppliances.com/register)

---

## Schedule Service

Expert GE Appliances repair service is only one step away from your door. Go online and schedule your service at your convenience any day of the year. In the US: [GEAppliances.com/ge/service-and-support/service.htm](http://GEAppliances.com/ge/service-and-support/service.htm) or call 800.952.5039 (US) during normal business hours.

---

## Extended Warranties

Purchase a GE Appliances extended warranty and learn about special discounts that are available while your warranty is still in effect. You can purchase it online anytime. GE Appliances Services will still be there after your warranty expires. In the US: [GEAppliances.com/ge/service-and-support/shop-for-extended-service-plans.htm](http://GEAppliances.com/ge/service-and-support/shop-for-extended-service-plans.htm) or call 800.952.5039 (US) during normal business hours.

---

## Parts and Accessories

Individuals qualified to service their own appliances can have parts or accessories sent directly to their homes (VISA, MasterCard and Discover cards are accepted). Order online today 24 hours every day. In the US: [GEAppliances.com](http://GEAppliances.com) or call 800.952.5039 (US) during normal business hours.

**Instructions contained in this manual cover procedures to be performed by any user. Other servicing generally should be referred to qualified service personnel. Caution must be exercised, since improper servicing may cause unsafe operation.**

---

## Contact Us

If you are not satisfied with the service you receive from GE Appliances, contact us on our Website with all the details including your phone number, or write to:

In the US: General Manager, Customer Relations | GE Appliances, Appliance Park | Louisville, KY 40225  
[GEAppliances.com/ge/service-and-support/contact.htm](http://GEAppliances.com/ge/service-and-support/contact.htm)