

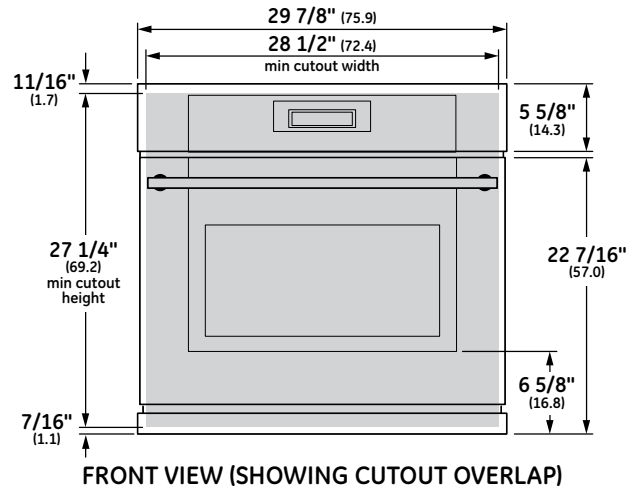

OVERALL DIMENSIONS

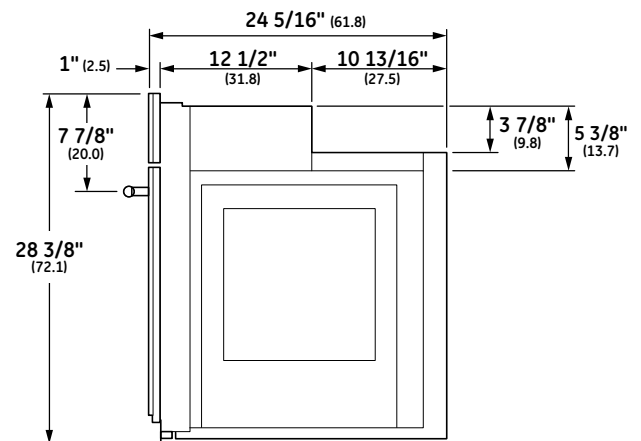

FRONT VIEW (SHOWING CUTOUT OVERLAP)



SIDE VIEW

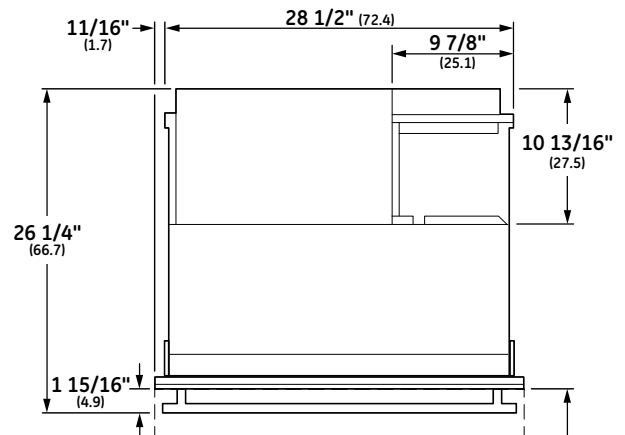

TOP VIEW



Dimensions in parentheses are in centimeters unless otherwise noted. Actual product dimensions may vary due to manufacturing tolerances.

SPECIFICATIONS

Overall Width	29 7/8" (75.9 cm)
Overall Height	28 3/8" (72.1 cm)
Overall Depth Including Handle	26 1/4" (66.7 cm)
Oven Door Clearance	21" (53.3 cm) Min
Overall Oven Interior Capacity	4.4 cu. ft. (124.6 l)
Oven Interior Dimensions (W x H x D)	24" x 16 1/4" x 18 1/4" (61.0 cm x 41.3 cm x 46.4 cm)
Minimum Cabinet Width*	30" (76.2 cm)
Minimum Cabinet Depth*	24" (61.0 cm)
Minimum Base Support	150 lbs (68 kg 38.9 g)
Cutout Width*	28 1/2" (72.4 cm) Min 28 5/8" (72.7 cm) Max
Cutout Height*	27 1/4" (69.2 cm) Min 27 5/16" (69.4 cm) Max
Cutout Depth*	23 1/2" (59.7 cm) Min
Volts/Hertz/Amps	240/208 V AC, 60 Hz, 20A
Conduit Length	48", 72" available special order: WB18T10398
Electrical Rating	3.0 kW at 208V 4.0 kW at 240V
Shipping Weight	135 lbs (61 kg 235 g)

* Additional space will be needed for flush installation.

ATTENTION ELECTRICIAN:

A 240/208V, 60Hz, 20 Amp circuit is required. An individual properly grounded branch circuit or circuit breaker is required. Hardware junction box is required for built-in product.



WALL INSTALLATION

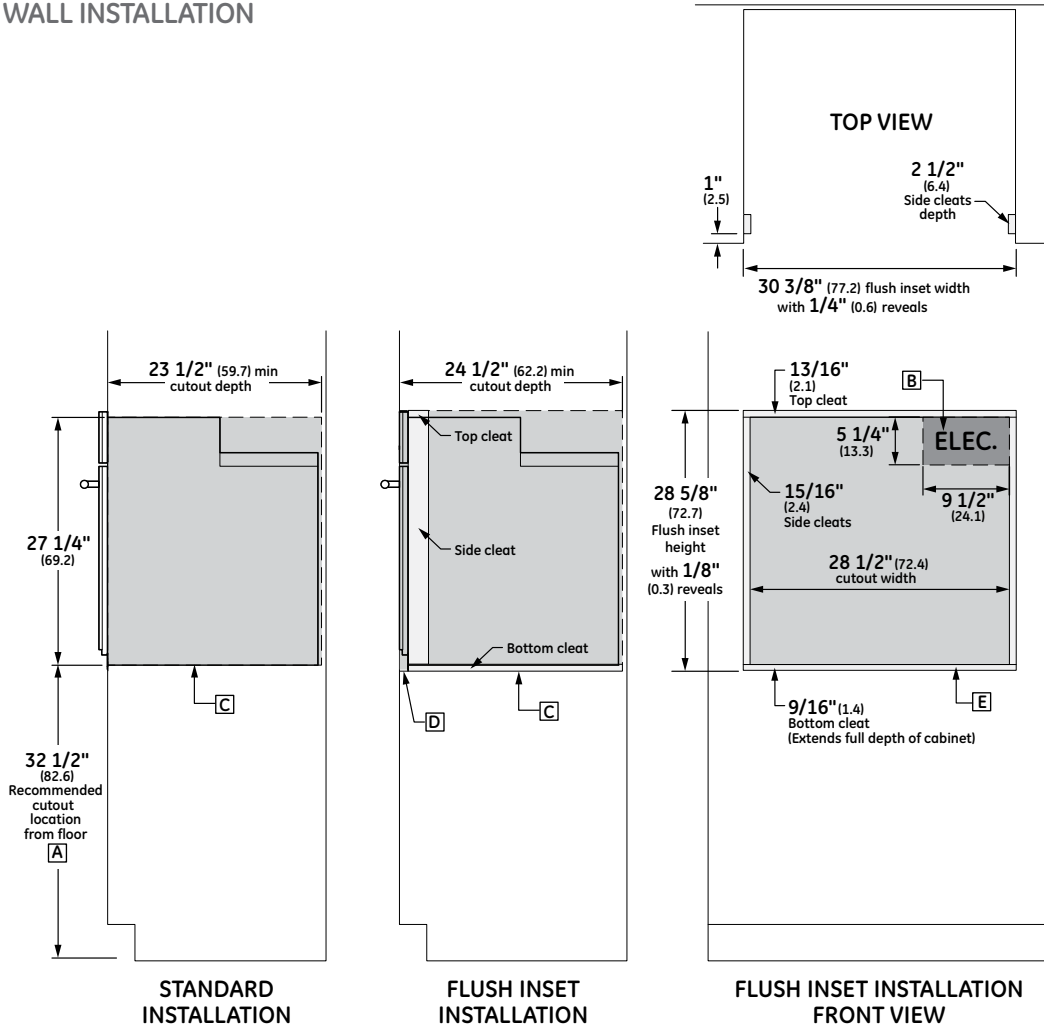

NOTES

- [A] Based on a user height of 5' 6" to 5' 10"
- [B] Junction box location (May also be located in adjacent cabinet.)
- [C] Platform must be able to support 200 lbs (90 kg)
- [D] Cabinet surfaces must be an appearance finished surface for flush installation.
- [E] Cleats may be visible and should be finished to match cabinetry.
- [F] Maximum toe kick height of 4" when installed beneath a certified cooktop.

Allow 1/4" (0.64 cm) clearances from side edges of oven door.

UNDERCOUNTER INSTALLATION

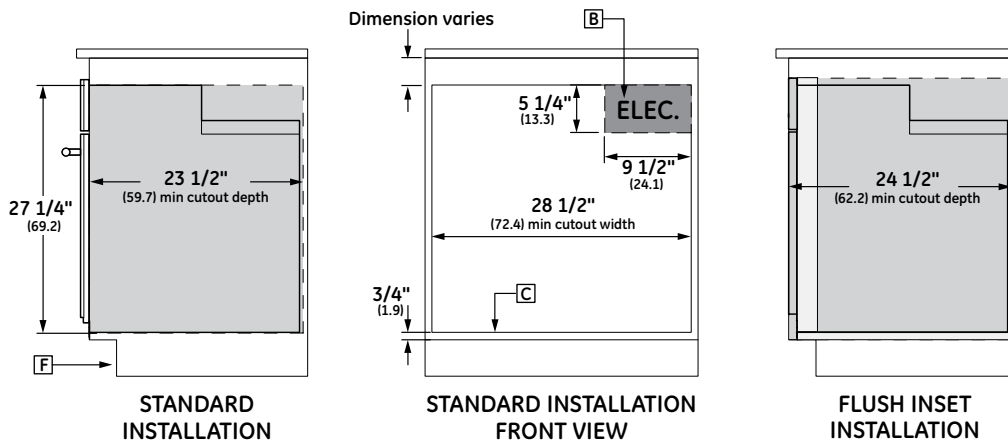

For more details, refer to the installation instructions for this product on Monogram.com. Dimensions in parentheses are in centimeters unless otherwise noted.

INSTALLATION WITH ADVANTIUM AND WARMING DRAWER

SIDE BY SIDE INSTALLATION

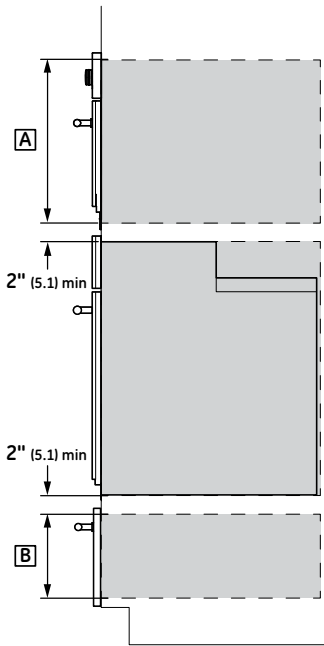

STANDARD INSTALLATION
SIDE VIEW

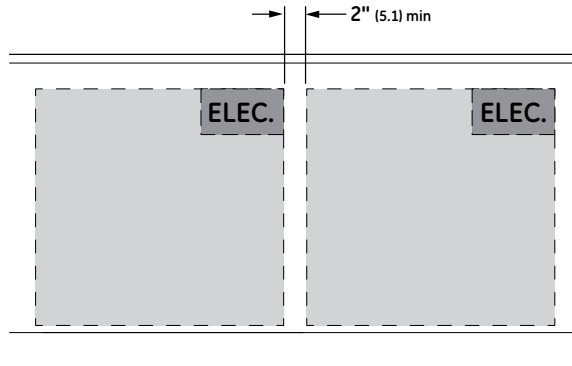

SIDE BY SIDE INSTALLATION
FRONT VIEW OF CUTOUTS

UNDER COOKTOP INSTALLATION

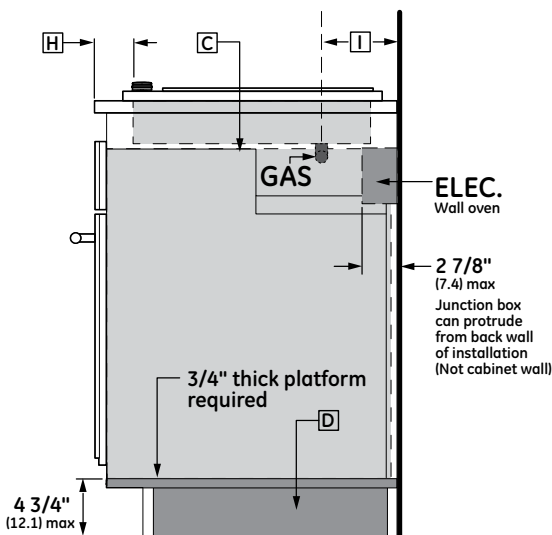

STANDARD INSTALLATION
SIDE VIEW

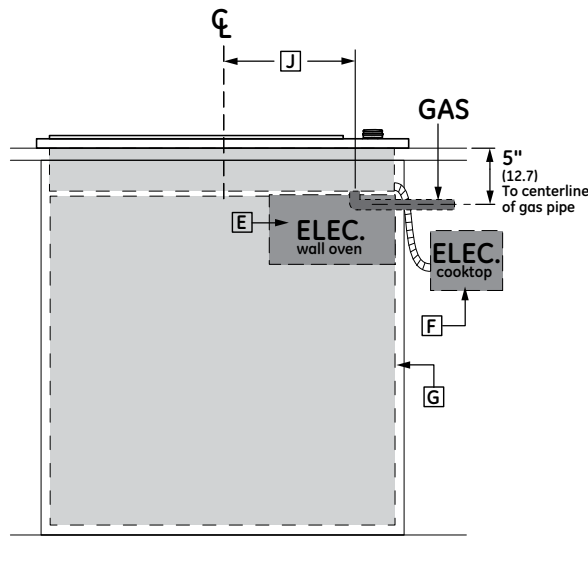

FRONT VIEW

NOTES

- A** Dimensions per Advantium or Microwave Oven requirement
- B** Dimension per Warming Drawer requirement
- C** Note this oven is only approved to be installed under specific models as labeled on this unit.
- D** Support platform made of 3/4" (1.9 cm) wood is required. Must be capable of supporting 200 lbs (90 kg). Support Platform base to be same height as toe kick.
- E** Junction box location for wall oven. (May also be located in adjacent cabinet).
- F** Gas regulator and electric connections for cooktops must be located in an adjacent accessible location to the right
- G** Top and/or side fillers may be necessary if unit is positioned between existing cabinets. Be sure they are attached securely, since they will anchor the oven in the cabinet.
- H** For flush oven installations, the cooktop cutout must be set back 2 1/2" (6.4 cm) plus the cleat setback.
- I** Dimension varies based on model.
example:
ZGU385 5 1/2" (14.0 cm) (from wall)
ZGU384 4 5/16" (11.0 cm) (from wall)
- J** Dimension varies based on model.
example:
ZGU385 0" (centerline)
ZGU384 12 1/16" (30.6 cm) (centerline)

For more details, refer to the installation instructions for this product on Monogram.com. Dimensions in parentheses are in centimeters unless otherwise noted.

FEATURES AND BENEFITS

Electronic Controls - As elegant as they are ergonomic

Halogen Light Columns - On the oven walls, provide brilliant task lighting for each rack position

Exclusive Self Cleaning, Full-Extension Oven Racks - Glide in and out smoothly on stainless steel ball bearings, and are designed to be left in the oven during the self-clean cycle

4.4 Cu. Ft. Capacity - Easily accommodates even the largest meals

True Hidden Bake Element - Concealed beneath the oven floor, allowing additional capacity and improved cleanability

Reverse-Air Convection System - Uses an innovative fan that reverses direction for optimal air and heat circulation, providing even cooking and multi-rack baking capability

Six-Element Design - Two bake, two broil and two convection elements provide precise cooking control, with fast preheating

208V Performance Compensation - Utilizes the six-element design to boost power in reduced voltage installations

Signature Tubular Handles - Are smooth, sleek and easy to grasp

Hand-Finished Edges - Reflect the meticulous quality and craftsmanship for which Monogram products are renowned

Two Broil Elements with Reflector Shield - Offer intense, dual-zone broiling



70 to 90% U.S. content. Product content details at GEAppliances.com/USA

