

Installation Instructions

Heat Pump Water Heater Ducting Kit

This manual is intended to act as a supplement to the Heat Pump Water Heater Use & Care Instructions. For additional information about the Heat Pump Water Heater, please consult the Heat Pump Water Heater Owner's Manual.

IMPORTANT SAFETY INSTRUCTIONS. READ ALL INSTRUCTIONS BEFORE USING.

⚠ CAUTION — Read entire manual.

Failure to follow these warnings can result in personal injury or property damage.

- Check with your local building inspector for building and HVAC codes. You must follow all governing codes and guidelines as you install the Water Heater Ducting Kit.
- To reduce the risk associated with the operation of power tools, always follow the manufacturer's suggested instructions for any tools used during this process.
- To reduce the risk of property damage, do not attach rigid ducting to the Water Heater Ducting Kit with screws. It is recommended to use insulated flexible ducting with the appropriate insulation R value for your application. Consult an HVAC professional for questions concerning the installation.

TOOLS AND MATERIALS NEEDED

- Drill with Phillips #2 bit
 - T-20 Torx Screwdriver
 - Phillips #2 Screwdriver
 - 8" Insulated Flexible Ducting*
 - Ducting Support Hangers*
 - Exterior Wall Vents for Inlet & Outlet*
- * Materials sold separately.

PARTS INCLUDED

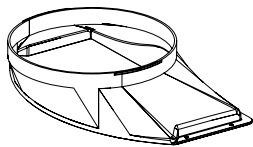

Upper Inlet Duct Adapter

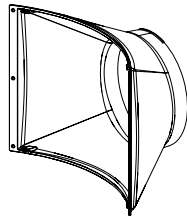

Outlet Duct Adapter

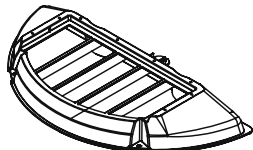

Lower Inlet Duct Adapter

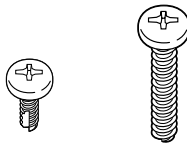

Drilling Screws (6) Assembly Screws (8)

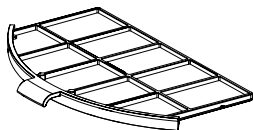

Inlet Duct Filter



8" Hose Clamps (2)

CLEARANCES

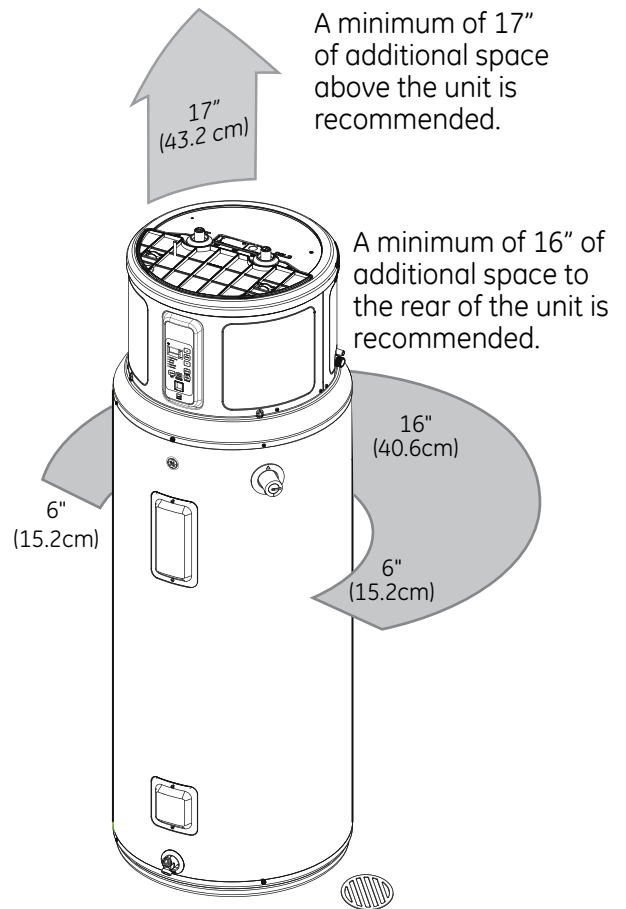

Figure 1

Installation Instructions

BEFORE YOU START

Consider all of the following when installing a Heat Pump Water Heater Ducting Kit.

- The Heat Pump Water Heater Ducting Kit requires additional space around the water heater to allow for proper installation of the kit (see Figure 1). Installed Heat Pump Water Heaters may have to be reinstalled to meet minimum clearance requirements.
- It is recommended that the rear of the Heat Pump Water Heater be faced away from any walls to allow for easier installation of the OUTLET adapter and OUTLET duct work. In the event that this is not possible, a minimum of 16" of additional space to the rear of the water heater and 17" of additional space above the water heater (not including inlet and outlet) is recommended to properly install the ducting kit (see figure 1).
- Total equivalent (straight) duct work length of the INLET and OUTLET ducting combined must be less than 100 feet (see DUCT LENGTH section). Installed Heat Pump Water Heaters may have to be reinstalled to meet equivalent duct length requirements. Consult an HVAC professional for questions concerning the installation.
- On new Heat Pump Water Heater installations select a location for the water heater that will allow for easy duct kit installation, meet clearance requirements, and minimize the length and number of elbows of the INLET and OUTLET duct work. Use the table in the DUCT LENGTH section to calculate the total equivalent straight length of duct work. Total equivalent duct work length of the INLET and OUTLET ducting combined must be less than 100 feet. Consult an HVAC professional for questions concerning the installation.
- Install any duct termination in accordance with local building codes with appropriate inlet/outlet air dampers.
- Acquire additional materials to complete proper installation of ducting kit.

DUCTING LENGTH

Using ducting longer than specified length will:

- Increase the water heater recovery times and the energy cost.
- Reduce the water heater fan life.
- Induce dirty filter faults due to lack of proper air flow. Refer to Step 6 #2 for more details.

The correct ducting installation is YOUR RESPONSIBILITY.

Problems due to incorrect installation are not covered by the water heater warranty

The MAXIMUM ALLOWABLE length of the ducting system depends upon the type of duct, number of turns, the type of ducting hoods (wall cap) and all conditions noted on the chart. All ducting used with the system should be 8" in diameter, unless a separate booster fan has been installed.

DUCTING LENGTH (continued)

- Any elbow/bend greater than 45° should be treated as a 90° elbow/bend.
- Two 45° elbows/bends will be treated like one 90° elbow/bend.
- For every additional 90° elbow/bend, reduce the allowable vent system length by 13 feet.
- When calculating the total vent system length, you must add all the straight portions and elbows of the system for both inlet and outlet ducts. Equivalent straight duct length should not exceed 100 feet.

Typical 8" Wall Cap/ Vent Hood

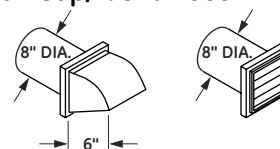

INSULATED FLEXIBLE 8" DUCTING

No of 90° elbow/bends	Equivalent straight duct length	
	Internal Installation - Vented inside ONLY NO Wall Cap/Vent Hood	Outside Installation - Vented outside with Wall Cap/Vent Hood
0	100	70
1	87	57
2	74	44
3	61	31
4	48	18

STEP 1 - WATER HEATER AND AREA PREPARATION

1. Remove power from the water heater at the fuse or breaker panel before proceeding with installation. The unit does not have a power button, so this precaution must be taken before proceeding. During this installation, the unit will not be producing hot water. Because of this, it is recommended to plan hot water usage around the installation of this ducting kit
2. Remove the original filter from the top of the water heater by pressing on the tabs and lifting it away from the unit. This filter may be discarded or stored for future non-ducted usage. Under no circumstances should the Heat Pump Water Heater be operated without a filter in place.

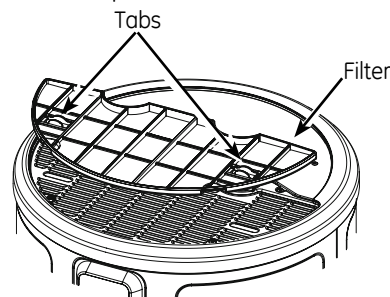
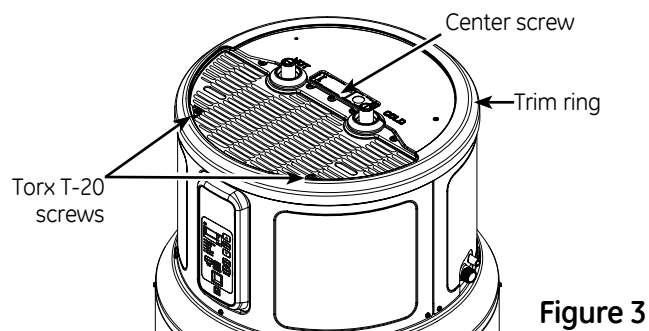

Figure 2

Installation Instructions

STEP 2 - INLET DUCT ADAPTER INSTALLATION

1. Remove the two Torx T-20 screws retaining the trim ring and the center screw and place them aside. These screws will be reused. Do not remove the trim ring.



2. Assemble the upper inlet duct adapter to the lower inlet duct adapter by aligning the holes as shown in Figure 4 and installing the 8 assembly screws. These screws should be tightened by hand with a Phillips #2 screwdriver to prevent over-tightening.

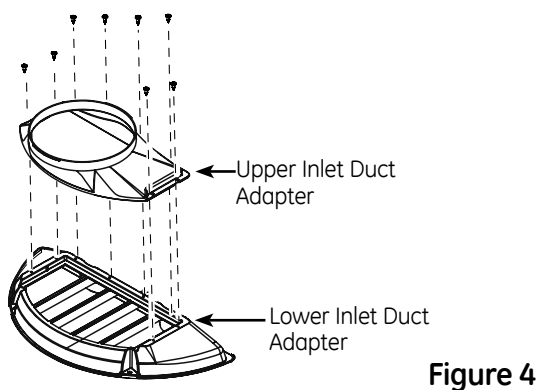

3. Orient the inlet duct assembly to the top of the water heater by aligning the holes as shown in Figure 5. Use the three screws from Step 2 #1 to secure the Inlet Duct Assembly to the water heater.

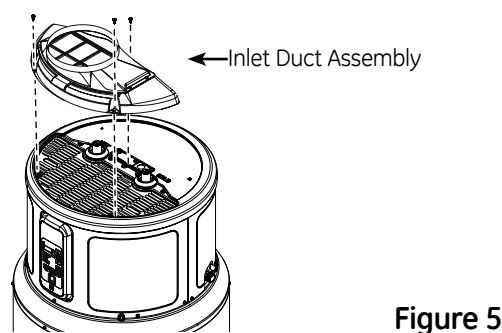

STEP 2 - INLET DUCT ADAPTER INSTALLATION (continued)

4. Install the air filter by sliding it into place in the inlet duct adapter assembly.

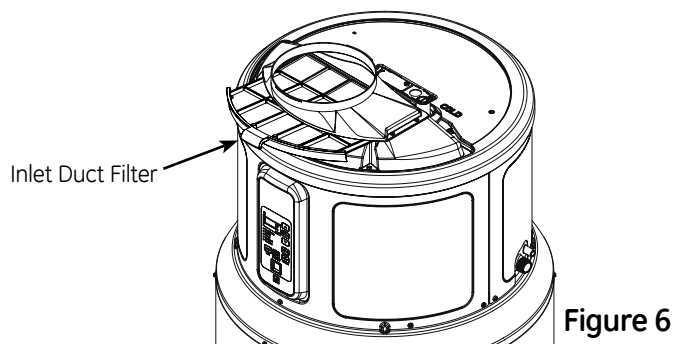

STEP 3 - OUTLET DUCT ADAPTER INSTALLATION

1. Orient the outlet duct adapter as shown in Figure 7 by aligning the locating features with the corner holes in the rear shroud grille opening.

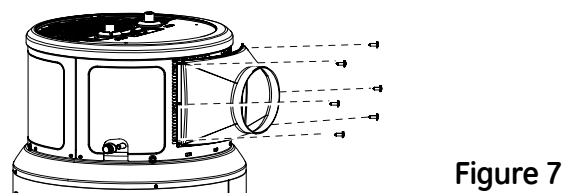

2. Using a high speed drill, install the outlet duct adapter by screwing the included drilling screws into the metal water heater shroud over the grille opening. Do not over-tighten the screws and take care if removing the screws to avoid any metal shavings or sharp edges created during the drilling process.

NOTE: It may be necessary to use a center punch to create dimples in the rear shroud cover to get the screws started. If there is difficulty installing the screws, it may be necessary to increase the drill's speed. To reduce the risk associated with water heater damage, use only the supplied drilling screws. **DO NOT USE A DRILL BIT TO DRILL INTO THE MACHINE COMPARTMENT.**

Installation Instructions

STEP 4 - FLEXIBLE DUCT ATTACHMENT TO INLET AND OUTLET ADAPTORS

NOTE: The fan included in the water heater is designed to support up to a combined inlet and outlet equivalent straight length of 100 feet of 8" insulated flexible ducting. Certain ducting geometries have length equivalencies that are greater than their actual length. Use the table in the DUCT LENGTH section to calculate the equivalent length of ducting on both the inlet and outlet sides. If this combined length is over 100 equivalent feet, a separate inline booster fan may be installed to assist with air flow.

1. Determine the desired length of the outlet duct and carefully trim it to length using the manufacturer's suggested method. This may require the use of wire cutters if wire bound ducting is used.
DO NOT ATTACH RIGID DUCTING TO THE WATER HEATER DUCTING KIT WITH SCREWS.
2. If insulated ducting is used (recommended), peel back the ducting insulation to expose the ducting and position one of the included clamps over the exterior of the exposed ducting.
3. Slide one end of the ducting over the outlet duct adapter installed earlier and secure the ducting with by tightening the clamp around the outlet duct adapter assembly opening. Use ducting supports as required by local ordinances. For horizontal runs of ducting, care should be taken to eliminate large dips in the ducting, which can accumulate moisture from condensation.
4. Route the other end of the ducting to the outlet air area.
5. Repeat steps 1-3 for inlet duct.
6. Route the other end of the ducting to the inlet air source area.

Be sure to add appropriate means to prevent the following:

- a. Accumulation of debris.
- b. Entrance of insects, rodents and other small animals.
- c. Rainwater accumulation.

Install any duct termination in accordance with local building codes with appropriate inlet/outlet air dampers.

STEP 5 - OPERATION RESTORATION

1. Restore power to the unit at the fuse or breaker panel referenced earlier.

NOTE: Models produced prior to 2015 may not offer this enhancement, and have not been verified Northern Climate Specification Tier 2 or Tier 3 compatible. It is still possible to apply this ducting kit to pre-2015 Heat Pump Water Heaters, but efficiency impact, anticipated to be negligible, has not been confirmed.

2. This step is optional for moderate and southern climate users; required for NEEA Northern Climate Tier 3 Compliance. On the user interface, press the down arrow and the filter button at the same time and hold for 5 seconds to enter Ducting Mode. The unit will signify that it is operating in Ducting Mode by temporarily displaying "duc" on the user interface display and playing an audible tone. This can be reversed by pressing and holding the filter and down arrow buttons for 5 seconds once more. The unit will signify that it is operating in Standard Mode by temporarily displaying "Std" on the user interface display and playing an audible tone.

NOTE: In Ducting Mode, the unit will notify the user that the electric elements are being used by flashing the "ELECTRIC" LED on the user interface panel. This occasional operation is normal and the Heat Pump Water Heater will restore compressor operation as soon as conditions return to allowable control parameters. Additionally, the unit will indicate that it is in Ducting Mode by flashing the respective operation mode (e.g.: HEAT PUMP, HYBRID, etc.).

3. Press and hold the filter button to reset the filter life indicator.

OPERATION AND TROUBLESHOOTING

- The Heat Pump Water Heater when operated in HYBRID Mode with inlet temperatures below 35°F will automatically switch to electric elements temporarily. It is recommended to change the inlet air source to a warmer source during this condition to increase energy efficiency.
- Refer to the Hybrid Water Heater Manual for filter care instructions. If the unit continually indicates that the filter needs to be serviced, it is recommended that the calculated run length of the ducting be checked using the method described in the Ducting Length section. If this is within specified limits, check for obstructions. If there are no obstructions, a separate inline booster fan may be installed to assist with air flow. If this does not correct the situation, contact customer service.
- In the event that outdoor temperatures reach levels above those within the household, but not more than 15° F above household temperatures, it may be beneficial to duct outlet air from the water heater into the conditioned space to assist with cooling.