

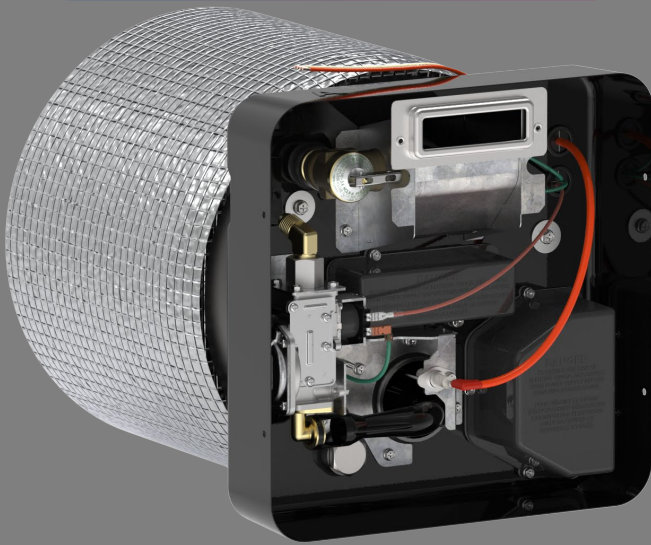

# RV Dual Fuel Water Heater Features & Performance

Water heaters designed for maximum performance, ease of installation and maintenance.

## 120 Volt + LP Gas



### Installation In Mind

Designed to fit into industry standard cutout, including 6' power cord, 3/8" gas fitting and 1/2" MNPT water connections.

### Durable Design

Two integrated hinges and latches offer secure, easy access. Integrated interior gaskets allow secure sealing, reduced door vibration and proper air flow.

### Secured Controls

Fully enclosed control board securely located to protect from exterior elements or interior accidents. Complies with ANSI Z21.10.1-2019.

### Easy Maintenance

Direct access to anode rod allows for ongoing maintenance to keep your water heater running longer.

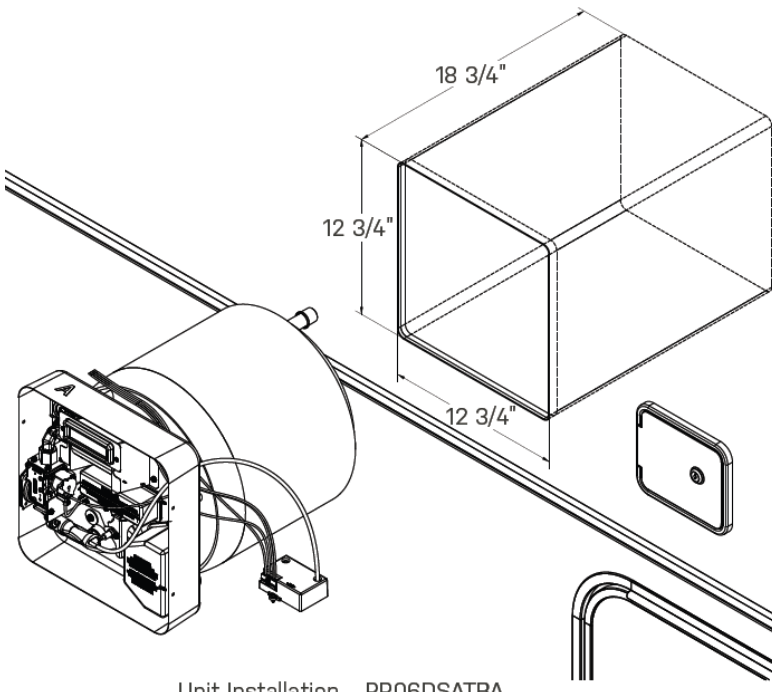

Unit Installation - PR06DSATBA



# GE Profile™ RV Dual Fuel Exterior Doors & Controls

Additional accessories to complete RV water heating packages



Durable design with two integrated stainless-steel hinges offer easy access.

Dual latches keep door securely closed while moving.

Textured, durable powder coat finish helps prevent scratches.



Model Number	Description
PM6WRS	Profile RV 6G Dual Fuel Exterior White Door
PM6BRS	Profile RV 6G Dual Fuel Exterior Black Door
PM0WRS	Profile RV 10G Dual Fuel Exterior White Door
PM0BRS	Profile RV 10G Dual Fuel Exterior Black Door
PMCSRS	Profile RV Dual Fuel White Toggle Control for LP and Electric Water Heater

Visit to learn more <http://geappliances.com/rv-appliances>