

**Hotpoint®**

Simply  
yours

THE BEAUTY OF BASIC



Hotpoint® appliances are designed with

two ideas in mind: **simplicity** & **purpose**.

**Sleek lines** give you the **look you want** on

the outside, while **reliable performance**

on the inside keeps your life **running smoothly**.

Dinner is cooked to **perfection**.

Dishes are **clean**. Your leftovers are packed away  
in the refrigerator. Laundry is **done**.

That's **simplicity**  
**you can count on.**

NOW AVAILABLE  
IN STAINLESS STEEL



The classic finish is now offered on select Hotpoint models,  
so you can build your dream kitchen on a budget.

## TABLE OF CONTENTS

Cooling products.....	4
Cooking products.....	10
Cleaning products.....	16
Specifications.....	22
Warranties.....	30
Nomenclatures.....	32
Parts.....	33
Consumer services.....	Back



GE appliances help you conserve energy and save money. We have been an ENERGY STAR® Partner for 10 years. We are committed to creating energy-efficient, high-performance household appliances and lighting products.



Compliant with the Americans  
With Disabilities Act



Appliances with this icon are Made  
in America and contain 70 to 90%  
U.S. content. Product content  
details at [geappliances.com/USA](http://geappliances.com/USA)

cooling

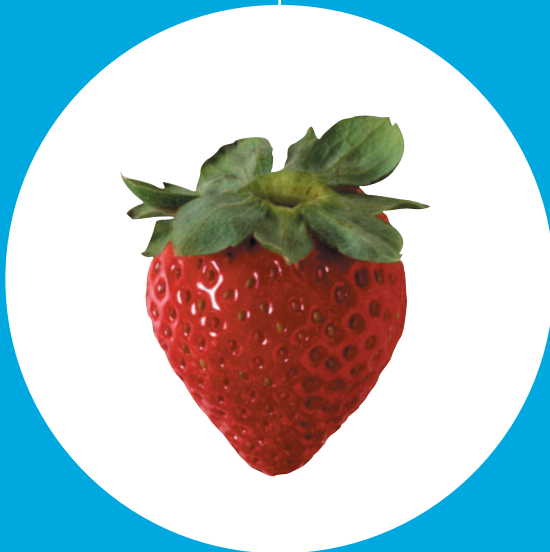

Practical.  
Convenient.

Hotpoint® refrigerators  
make it easy to **stay**  
**cool.**



## SIDE-BY-SIDE REFRIGERATOR

### features



**1. INTEGRATED SHELF SUPPORT SYSTEM**

Provides strong, flexible support.

**2. ADJUSTABLE SLIDE-OUT, SPILLPROOF GLASS SHELVES**

Raised edges help contain spills and make cleanup quick and easy.

**3. FRESH FOOD MULTI-LEVEL DRAWERS**

Provide the ideal environment for storing your fruits and vegetables.

**4. ADJUSTABLE DOOR BINS**

Create additional storage space for milk and other gallon-size containers.

## TOP-FREEZER REFRIGERATORS

### features



**1. UPFRONT TEMPERATURE CONTROLS**

Easy-to-use controls regulate both fresh food and freezer sections.

**2. ADJUSTABLE WIRE SHELVES**

Moveable racks can handle a variety of foods.

**3. FIXED GALLON DOOR SHELVES**

Provide the ideal space for storing gallon containers in the door.

**4. CAN STORAGE DOOR SHELF**

Holds cans in the door for easy selection and quick access.

*Not all features available on all models.*



**HPS18BTH**

- 17.6 cu. ft. capacity
- Upfront temperature controls
- Adjustable wire shelves
- Fixed gallon door shelves
- Sealed drawers with glass cover
- Can storage door shelf
- Equipped for optional icemaker
- Full-width wire freezer shelf

 HPS18BTHWW

 HPS18BTHBB





**HPE15BTH**

- 14.6 cu. ft. capacity
- Upfront temperature controls
- Adjustable wire shelves
- Fixed gallon door shelves
- Sealed drawers with glass cover
- Equipped for optional icemaker
- Full-width wire freezer shelf

 HPE15BTHWW



**HPS15BTH**

- 14.6 cu. ft. capacity
- Upfront temperature controls
- Adjustable wire shelves
- Fixed gallon door shelves
- Sealed drawers with glass cover
- Equipped for optional icemaker
- Full-width wire freezer shelf

 HPS15BTHRWW

 HPS15BTHLWW

 HPS15BTHRCC

 HPS15BTHLCC

 HPS15BTHRBB



 Stainless steel

 White

 Bisque

 Black

See page 30 for ADA requirements.  
For definitions of logos, see page 3.





**HSS25ASH**

- 25.4 cu. ft. capacity
- Integrated shelf support system
- Adjustable slide-out, spillproof glass shelves
- Fresh food multi-level drawers
- Adjustable door bins

- HSS25ASHSS
- HSS25ATHWW
- HSS25ATHBB



- Stainless steel
- White
- Black

See page 30 for ADA requirements.  
For definitions of logos, see page 3.

cooking



With all the features  
you need, Hotpoint®  
ranges & microwaves  
do more than just  
heat things  
up in the kitchen.



## 30" FREE-STANDING ELECTRIC RANGES



## features



1 2  
3 4

### 1. SELF-CLEAN OVEN

Cleans the oven cavity without the need for scrubbing.

### 2. 5.0 CU. FT. OVEN CAPACITY

Can cook multiple dishes at once, making big dinners and holiday meals a breeze.

### 3. RIBBON HEATING ELEMENTS

Provide powerful, even heat with a smooth, scratch-resistant glass surface.

### 4. TOUCHPAD CONTROLS

Make it simple to control oven functions and add to its sleek, modern look.

*Not all features available on all models.*

### RB780

- Self-clean oven
- Ceramic-glass cooktop
- Ribbon heating element
- 5.0 cu. ft. oven capacity
- Electronic oven controls
- Frameless glass oven door
- Two oven racks

 RB780RHSS

 RB780DHWW

 RB780DHBB

 Stainless steel

 White

 Bisque

 Black

 Silver metallic

## 30" FREE-STANDING GAS RANGES

### features



#### 1. SEALED GAS BURNERS

Contain spills and prevent boiling-over liquids from dripping beneath cooktop.

#### 2. SELF-CLEAN OVEN

Cleans the oven cavity without the need for scrubbing.

#### 3. 12,500 BTU BURNER

Provides high output for faster boiling and quick heating.

#### 4. 4.8 CU. FT. CAPACITY

Can cook multiple dishes at once, making big dinners and holiday meals a breeze.

*Not all features available on all models.*



#### RGB780

- Self-clean oven
- 4.8 cu. ft. capacity
- Sealed cooktop burners
- Simmer burner
- 12,500 BTU burner
- Black steel grates
- In-oven broiling

	RGB780REHSS
	RGB780DEHWW
	RGB780DEHCC
	RGB780DEHBB



**RGB530**

- Standard clean oven
- 4.8 cu. ft. oven capacity
- Sealed cooktop burners
- Simmer setting
- All-purpose burners
- Electronic oven control

RGB530DEHWW  
 RGB530DEHBB



**RGB526**

- Standard-clean oven
- 4.8 cu. ft. oven capacity
- Sealed cooktop burners
- Simmer burner
- Porcelain upswept cooktop
- All-purpose burners

RGB526DEHWW  
 RGB526DEHBB



**RGB525**

- Standard-clean oven
- 4.8 cu. ft. oven capacity
- Standard grates
- All-purpose burners
- Porcelain upswept cooktop
- Lift-up cooktop

RGB525DEHWW  
 RGB525DEHBB



**RGB518**

- Standard-clean oven
- 4.8 cu. ft. oven capacity
- All-purpose burners
- Cordless battery ignition
- Porcelain upswept cooktop
- Lift-up cooktop

RGB518PCHWH  
 RGB518PCHCT



**RGB508**

- Standard-clean oven
- 4.8 cu. ft. oven capacity
- All-purpose burners
- Broiler drawer
- Electronic pilotless ignition

RGB508PEFWH  
 RGB508PEFCT



**RGA824**

- Standard-clean oven
- Electronic pilotless ignition
- Standard window
- Interior oven light
- Porcelain upswept cooktop
- Dropdown broiler
- Two oven racks
- Broiler pan with grid

RGA824DEDWW



**RGA724**

- Standard-clean oven
- Electronic pilotless ignition
- Porcelain-enameled oven door
- Recessed, lift-up cooktop
- Continuous grates
- Two oven racks
- Dropdown broiler
- All-purpose burners
- Broiler pan with grid

RGA724EKWH



**RGA820**

- Standard-clean oven
- Electronic pilotless ignition
- Standard window
- Interior oven light
- Porcelain upswept cooktop
- Broiler drawer
- Two oven racks

RGA820DEDWW



**RGA720**

- Standard-clean oven
- Electronic pilotless ignition
- Porcelain-enameled oven door
- Recessed, lift-up cooktop
- Continuous grates
- Two oven racks
- Broiler drawer
- All-purpose burners

RGA720EKWH



Stainless steel
  White
  Bisque
  Black

See page 30 for ADA requirements.  
For definitions of logos, see page 3.



### RB720

- Self-clean oven
- 5.0 cu. ft. oven capacity
- Coil heating elements
- Electronic oven controls
- Frameless glass oven door
- Porcelain upswept cooktop
- Two oven racks



### RB560

- Standard-clean oven
- Ceramic-glass cooktop
- Ribbon heating element
- 5.0 cu. ft. oven capacity
- Electronic oven controls
- Frameless glass oven door
- Two oven racks



### RB526

- Standard-clean oven
- Coil heating elements
- Electronic clock and kitchen timer
- Porcelain upswept cooktop
- Two oven racks

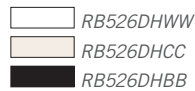

### RB525

- Standard-clean oven
- Coil heating elements
- Porcelain upswept cooktop
- Two oven racks
- Removable full-width storage drawer

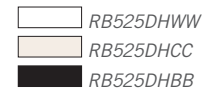

## 24" & 20" COMPACT ELECTRIC RANGES



### RA824

- Standard-clean oven
- One 8" and three 6" plug-in heating elements with chrome drip bowls
- Interior oven light
- Lift-up cooktop with porcelain-enameled subtop
- Standard window
- Broiler pan with grid



### RA724

- Standard-clean oven
- One 8" and three 6" plug-in heating elements with chrome drip bowls
- Lift-up cooktop with porcelain-enameled subtop
- Two heating element "ON" indicator lights
- Two oven racks
- In-oven broiling
- Broiler pan with grid



### RA820

- Standard-clean oven
- One 8" and three 6" plug-in heating elements with chrome drip bowls
- Interior oven light
- Lift-up cooktop with porcelain-enameled subtop
- Standard window



### RA720

- Standard-clean oven
- One 8" and three 6" plug-in heating elements with chrome drip bowls
- Lift-up cooktop with porcelain-enameled subtop
- Two heating element "ON" indicator lights
- Two oven racks
- In-oven broiling
- Broiler pan with grid



## HOOD



### RN328

- 30" width
- Non-vented
- Variable two-speed fan control
- Cooktop light
- Removable grease filter



## MICROWAVE OVEN



### 1. POPCORN

Maximizes popping without scorching pre-packaged popcorn.

### 2. TURNTABLE

Continually rotates food to ensure even cooking.



### RVM5160

- 1.6 cu. ft. cavity
- Convenience cooking controls
- Weight and Time Defrost
- Turntable
- Two-speed, 200-CFM venting system



See page 30 for ADA requirements.  
For definitions of logos, see page 3.

cleaning



From dishes  
to laundry,  
Hotpoint® helps  
you **keep it**  
**clean.**





## DISHWASHERS

### features



- 1. HOT START OPTION**  
 Provides optimal water temperature for dependable performance.
- 2. PIRANHA™ HARD-FOOD DISPOSER**  
 Grinds leftover food into small particles that are easily washed away.
- 3. ENERGY STAR® QUALIFIED**  
 Select models are certified to meet ENERGY STAR guidelines.
- 4. OUTSTANDINGLY QUIET PERFORMANCE**  
 Excellent wash performance, quiet operation and dependability make Hotpoint a reliable choice.

*Not all features available on all models.*



### HDA3600D

- 5-level wash system
- 2-stage filtration with Extra Fine filter
- Piranha hard-food disposer
- Insulation blanket
- Deluxe upper rack
- Pots & Pans cycle
- Hi-Temp Wash
- 5 cycles/3 options
- Rinse Only cycle

 HDA3600DWW

 HDA3600DBB



# features

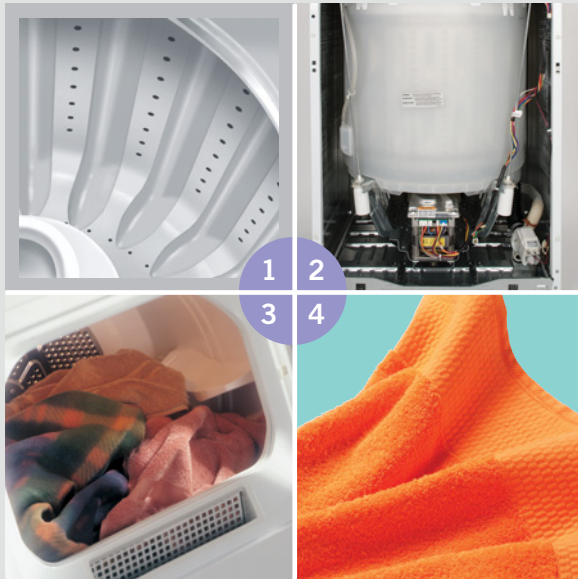

- 1. EXTRA ACTION RIBBED BASKET**  
 Provides additional surface area for fabrics, extracting more moisture during final spin.
- 2. AUTO-BALANCE SUSPENSION SYSTEM**  
 Handles the heaviest loads without banging or walking.
- 3. EXTRA-LARGE DRYER DOOR OPENING**  
 Makes for easier loading and unloading.
- 4. AUTOMATIC DRY CONTROL**  
 Monitors temperature and ends the cycle when clothes are properly dried.

*Not all features available on all models.*

White

## WASHERS



### HTWP1400F

- 3.7 DOE\* cu. ft. capacity washer
- 4 water levels
- 8 wash cycles
- 3 wash/rinse temperature settings
- Dual-action agitator
- Optional Power Rinse
- 630 RPM

HTWP1400FWW



### HSWP1000M

- 3.5 DOE\* cu. ft. capacity washer
- 3 water levels
- 8 wash cycles
- 3 wash/rinse temperature settings
- Dual-action agitator
- 630 RPM

HSWP1000MWW





## DRYERS



### HTDP120ED electric HTDP120GD gas



- 6.8 cu. ft. capacity dryer
- 4 temperatures
- 6 dry cycles
- Quiet-by-Design
- Dura Drum interior
- Reverse-a-Door

 HTDP120EDWW  
 HTDP120GDWW



### HTDX100ED electric HTDX100GD gas



- 6.0 cu. ft. capacity dryer
- 3 temperatures
- 4 dry cycles
- Quiet-by-Design
- Dura Drum interior
- Reverse-a-Door

 HTDX100EDWW  
 HTDX100GDWW



### HTDX100EM electric HTDX100GM gas

- 6.0 cu. ft. capacity dryer
- 3 temperatures
- 3 dry cycles
- Quiet-by-Design
- Dura Drum interior
- Reverse-a-Door

 HTDX100EMWW  
 HTDX100GMWW

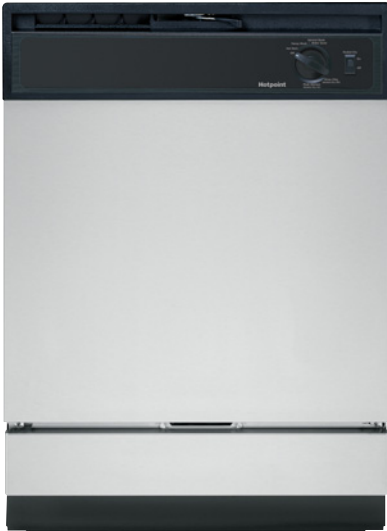

**HDA2160H**

- 4-level wash system
- 2-stage filtration with Extra Fine filter
- Piranha hard-food disposer
- Hot Start option
- Water Saver cycle
- Heavy Wash cycle
- Rinse Only cycle
- 5 cycles/2 options

 HDA2160HSS



**HDA2100H**

- 4-level wash system
- 2-stage filtration with Extra Fine filter
- Piranha hard-food disposer
- Hot Start option
- Water Saver cycle
- Heavy Wash cycle
- Rinse Only cycle
- 5 cycles/2 options

 HDA2100HWW

 HDA2100HCC

 HDA2100HBB



# REFRIGERATION SPECIFICATIONS

Side-by-Side Refrigerator	HSS25ASH HSS25ATH
<b>Capacity</b>	
Total (cu. ft.)	25.4
Fresh food (cu. ft.)	15.7
Freezer (cu. ft.)	9.7
<b>Fresh food features</b>	
Upfront electronic digital temperature display	●
Upfront electronic temperature controls	●
GE water filtration system	MWF
Dispenser	Cubed ice & water
Light	●
Cabinet shelves	4 glass
Adjustable	3
Slide-out, spillproof	3 (2 slide-out)
2-stack drawer system	●
Top drawer	Adj. humidity
Bottom drawer	Sealed
Door bins	4 (2 adj. w/gallon storage)
Dairy compartment	●
Interior lighting	●
<b>Freezer features</b>	
Frost Guard technology	●
Factory-installed icemaker	●
Wire cabinet shelves	3 wire
Storage basket(s)	1 slide-out
Door shelves	3 (2 adj.)
Interior light	●
<b>Appearance</b>	
Color(s) available*	SS WW, BB Black CM
Handle color	Black CM
Handle design	D-shaped
Exterior design	Rounded doors Case only (black)
Textured steel case	CM
<b>Weights &amp; Dimensions</b>	
Height to top of hinge (in.) A	69-1/4
Height to top of case (in.) B	68-3/4
Case depth without door (in.) C	29-1/2
Case depth less door handle (in.) D	32-3/4
Case depth with door handle (in.) E	35-1/8
Depth w/fresh food door open 90° (in.) F	51-5/8
Width (in.) G	35-3/4
Width w/door open 90° with door handle (in.) H	40-3/4
	Each side (in.) 1/8
	Top (in.) 1
Air clearances	Back (in.) 2
Approx. shipping wt. (lbs.)	340
Power/Ratings	120V, 60Hz, 15Amps

\*Color(s) available: SS=Stainless steel, WW=White, BB=Black, CM=Color-matched.

ALL MODELS AVAILABLE IN U.S. AND CANADA.

## Side-by-Side Refrigerator

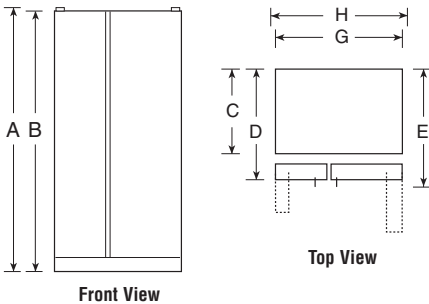

Top-Freezer Refrigerators	HPS18BTH	HPE15BTH	HPS15BTH
<b>ENERGY STAR® qualified</b>			
ADA compliant		●	●
<b>Capacity</b>			
Total (cu. ft.)	17.6	14.6	14.6
Fresh food (cu. ft.)	13.54	10.06	10.06
Freezer (cu. ft.)	4.01	4.01	4.01
<b>Fresh food features</b>			
Upfront temperature controls	●	●	●
Cabinet shelves	2 wire, 1 glass	2 wire, 1 glass	2 wire, 1 glass
Adjustable	2 full-width	2 full-width	2 full-width
Drawers	2 clear	2 clear	2 clear
Fixed door shelves	3 full-width (2 with gallon storage)	2 full-width with gallon storage	2 full-width with gallon storage
Dairy compartment	●	●	●
Interior light system	●	●	●
Never Clean condenser	●	●	●
<b>Freezer Features</b>			
Factory-installed icemaker	Opt. (IM4D)	Opt. (IM4D)	Opt. (IM4D)
Wire freezer compartment shelves	1 full-width	1 full-width	1 full-width
Fixed door shelves	2	2	2
<b>Appearance</b>			
Color(s) available*	WW, BB	WW	WW, CC, BB
Door handles*	CM recessed	CM recessed	CM recessed
Exterior design	Rounded doors	Rounded doors	Rounded doors
Reversible doors	●	●	R/LWW, R/LCC, R/BB
Choose right or left door opening			WW, CC only
Adjustable rollers	Front	Front	Front
<b>Weights &amp; Dimensions</b>			
Height to top of hinge (in.) A	67-3/8	61-3/4	61-3/4
Height to top of case (in.) B	66-7/8	61-1/4	61-1/4
Case depth without door (in.) C	26-5/8	25-3/4	25-3/4
Case depth less door handle (in.) D	30-1/2	29-1/2	29-1/2
Case depth with door handle (in.) E	30-1/2	29-1/2	29-1/2
Depth w/fresh food door open 90° (in.) F	56-3/4	55-7/8	55-7/8
Width (in.) G	28	28	28
Width w/door open 90° with door handle (in.) H	28-1/2	28-1/2	28-1/2
	Each side (in.) 3/4	3/4	3/4
	Top (in.) 1	1	1
Air clearances	Back (in.) 2	2	2
Approx. shipping weight (lbs.)	226	166	163

\*Color(s) available: WW=White, CC=Bisque, BB=Black, CM=Color-matched.

\*\*Available in right-hand door swing only.

ALL MODELS AVAILABLE IN U.S. AND CANADA.

## Top-Freezer Refrigerators

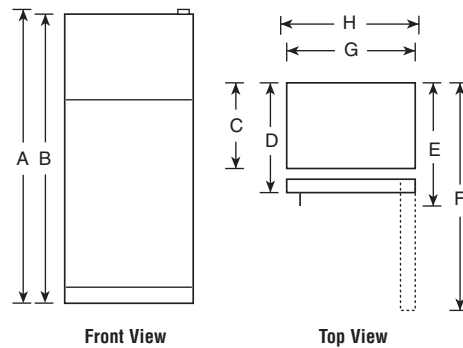

**Note: All Top-Freezer Right-Hand Refrigerator Doors:** As you face the front of the refrigerator, the handle is on your left and the hinges are on your right.

**All Top-Freezer Left-Hand Refrigerator Doors:** As you face the front of the refrigerator, the handle is on your right and the hinges are on your left.



Listed by Underwriters Laboratories

# 30" ELECTRIC RANGE SPECIFICATIONS

30" electric ranges	RB780RH RB780DH	RB720DH	RB560DH	RB526DH	RB525DH
<b>Features</b>					
Oven cleaning	Self-clean	Self-clean	Standard-clean	Standard-clean	Standard-clean
Oven capacity	5.0	5.0	5.0	5.0	5.0
Cleaning time	Variable	Variable			
Oven racks	2	2	2	2	2
Porcelain-enameled upswept cooktop	Radiant	Coil	Radiant	Coil	Coil
Patterned cooktop	●		●		
Lift-up cooktop		●		●	●
Element – Left front	6" 1500W	6" 1500W 4-turn	6" 1500W	6" 1250W 3-turn	6" 1250W 3-turn
Element – Left rear	8" 2000W	8" 2600W 5-turn	8" 2000W	8" 2100W 4-turn	6" 1250W 3-turn
Element – Right front	8" 2000W	8" 2600W 5-turn	8" 2000W	8" 2100W 4-turn	8" 2100W 4-turn
Element – Right rear	6" 1500W	6" 1500W 4-turn	6" 1500W	6" 1250W 3-turn	6" 1250W 3-turn
Ribbon heating elements	●		●		
Plug-in Calrod® heating elements		●		●	●
Removable one-piece drip bowls		Chrome, Chrome, Black		Chrome, Chrome, Black	Chrome, Chrome, Black
Electronic oven control	●	●	●		
Electronic clock and kitchen timer	●	●	●	●	
Electronic automatic oven timer	●	●	●		
Oven temperature display	●	●	●		
Auto oven shutoff	w/override	w/override	w/override		
Audible preheat signal	●	●	●		
Hot surface indicator lights	●	●	●		
Heating element "ON" indicator lights	●	●	●	●	●
Oven cycling light	●	●	●	●	●
Interior oven light	Control	Control	Control	Switch	
Self-clean cool down time display	●	●			
Delay Clean option	●	●			
Delay start	●	●	●		
<b>Appearance</b>					
Color appearance*	SS WW, BB	WW, CC, BB	WW, BB	WW, CC, BB	WW, CC, BB
Ceramic-glass cooktop	Black		Black		
Handle design	D-shaped	D-shaped	D-shaped	D-shaped	Visor
Handle color	Black CM	CM	CM	CM	CM
Full-width removable storage drawer	●	●	●	●	●
<b>Weights and Dimensions</b>					
Overall oven interior dimensions (W x H x D in inches)	← 23-3/4 x 19 x 18-1/2 →				
Approx. shipping weight (lbs.)	165	170	165	150	155
<b>Power/Ratings</b>					
KW rating @ 240V	10.5	11.7	11.7	10.1	10.1
@ 208V	7.9	8.8	8.8	8.7	8.0
Amp rating @ 240v/208v	40	40	40	40	40
Broiler/bake wattage	3410/2585	3410/2585	3410/2585	3410/2585	3410/2585

\*SS=Stainless steel, WW=White with white door, CC=Bisque with bisque door, BB=Black with black door, CM=Color-matched.

## 30" free-standing range installation information (in inches)

Dimensions from wall to front of closed oven door handle: 28-1/2" on models RB780/720/560; 28-3/8" on RB526; 28" on RB525.

The range may be placed with a 0" clearance (flush) at the back wall and side walls if the range side trims extend beyond the cabinet fronts at least 1/4". Self-clean models only.

## 30" electric range dimensions (in inches)

Models	A Width	B Height	C Depth	D Depth with door open
RB780	29-7/8	47-1/2	28-3/4	46-1/2
RB720	29-7/8	47-1/2	28-3/4	46-1/2
RB560	29-7/8	47-1/2	28-3/4	46-1/2
RB526	29-7/8	46-3/4	28-3/4	46-3/4
RB525	29-7/8	46-3/4	28-3/4	46-3/4

Dimensions from wall to front of closed oven door.

**Note:** 30" Electric Ranges conform to UL requirements for 0" spacing from walls below countertops. Allow 1-1/2" spacing from the side of the range to adjacent vertical walls above the cooktop surface.

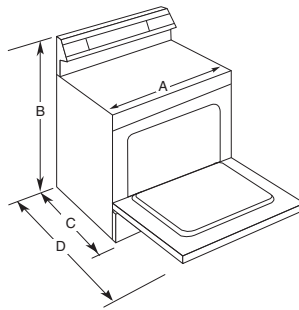

## Receptacle locations

Locally approved flexible service cord or conduit must be used because terminals are not accessible after range installation. See shaded area in drawing for location of electrical outlet box. Recommended outlet locations allow range to be installed directly against rear wall.

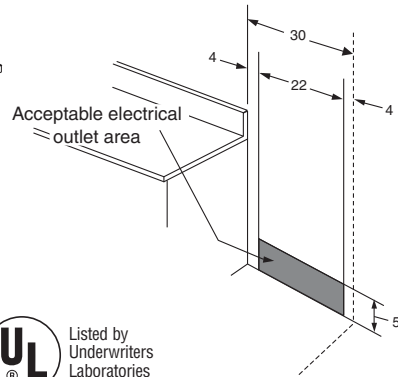

**Installation information:** Before installing, consult installation instructions packed with product for current dimensional data.



All Hotpoint ranges are equipped with an Anti-Tip device. The installation of this device is an important, required step in the installation of the range.

Above illustrations intended for dimensional reference only. Refer to photography for actual product appearance.

See page 30 for warranty information.

# 30" GAS RANGE SPECIFICATIONS

30" gas ranges	RGB780EH RGB780DEH	RGB530DEH	RGB526DEH	RGB525DEH	RGB518PCH	RGB508PEF
<b>Features</b>						
ADA compliant			●	●	●	●
Oven cleaning	Self-Clean	Standard-Clean	Standard-Clean	Standard-Clean	Standard-Clean	Standard-Clean
Oven capacity (cu. ft.)	4.8	4.8	4.8	4.8	4.8	4.8
Cooktop burners	Sealed	Sealed	Sealed	Twin	Twin	Twin
Burner – Right front	12,500 BTU	12,500 BTU	12,500 BTU	9,100 BTU	9,100 BTU	9,100 BTU
Burner – Right rear	5,000 BTU (Simmer)	5,000 BTU (Simmer)	5,000 BTU (Simmer)	9,100 BTU	9,100 BTU	9,100 BTU
Burner – Left front	9,500 BTU	9,500 BTU	9,500 BTU	9,100 BTU	9,100 BTU	9,100 BTU
Burner – Left rear	9,500 BTU	9,500 BTU	9,500 BTU	9,100 BTU	9,100 BTU	9,100 BTU
Oven controls	Electronic	Electronic	Knob	Knob	Knob	Knob
Automatic oven timer	●	●				
Porcelain-enameled cooktop	Upswept	Upswept	Upswept	Upswept	●	●
Lift-up cooktop					●	●
Easy-clean subtop					●	●
Valves (degree of turn)	140°	140°	140°	140°	140°	140°
Removable square grates	Black steel	Black steel	Black steel	Black steel	Black steel	Black steel
Ignition system	Electronic	Electronic	Electronic	Electronic	Battery Spark Pilot	Electronic
Oven racks	2	2	2	2	2	2
Six embossed rack positions	●	●	●	●	●	●
Interior oven light	●	●	●			
In-oven broiling	●					
<b>Appearance</b>						
Color appearance*	SS WW, CC, BB	WW, BB	WW, BB	WW, BB	WH, CT	WH, CT
Frameless oven door*	Stainless CM glass	CM Glass	CM	Solid CM	Solid CM	Solid CM
Handle design	D-shaped	D-shaped	D-shaped	Visor	Visor	Visor
Handle color	Black CM	CM	CM	CM	CM	CM
Slide-out broiler drawer		●	●	Dropdown door	Dropdown door	Dropdown door
Removable storage drawer	●					
<b>Weights and Dimensions</b>						
Overall oven interior dimensions (WxHxD in inches)	← 24 x 18-1/2 x 19 →					
Approx. shipping weight (lbs.)	210	170	160	170	160	160
<b>Power/Ratings</b>						
Gas range electrical rating	← 120V, 60 Hz, 5A →			← 9 VDC →		← 120V, 60 Hz, 5A →
Top burners† (000's BTU)	← (1) 11.0 (1) 5.0 →		← (4) 8.0 →			
LP	← (2) 9.5 →					
Oven/broiler burners† (000's BTU) NAT/LP	← 16.0/16.0 – Oven 12.5/12.0 – Broil →	← 18.0/16.5 →				
<b>Accessories</b>						
LP conversion kit	●	●	●	●	●	●

\*SS=Stainless steel, WW=White with white door, BB=Black on black, WH=White with black accents, CT=Bisque with black accents, CM=Color matched.  
†Factory set for natural gas.

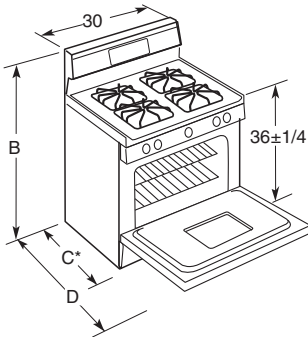

30" gas range dimensions (in inches)

Models	B Height	C* Depth	D Depth with door open
RGB780	46-7/8	28-3/4	46-3/8
RGB530	46-7/8	28-3/4	46-3/8
RGB526	46-7/8	28-3/4	46-3/8
RGB525	46-7/8	28-3/4	46-3/8
RGB518	39-7/8	28-3/4	46-3/4
RGB508	39-7/8	28-3/4	46-3/4

\*Depth from wall to front of closed oven door.

## 30" gas range installation information (in inches)

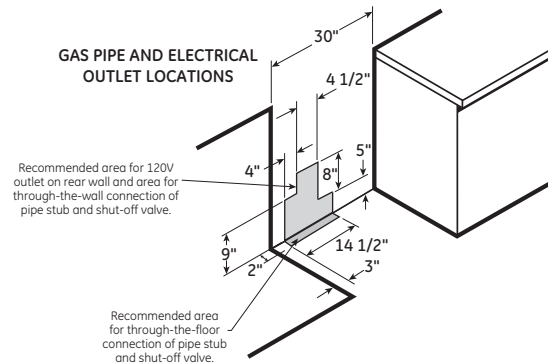

All Hotpoint ranges are equipped with an Anti-Tip device. The installation of this device is an important, required step in the installation of the range.



**Installation information:** Before installing, consult installation instructions packed with product for current dimensional data.



# COMPACT ELECTRIC & GAS RANGE SPECIFICATIONS

24" and 20" electric ranges	24" range RA824D	24" range RA724K	20" range RA820D	20" range RA720K
<b>Features</b>				
ADA compliant	●	●	●	●
Oven cleaning	Standard	Standard	Standard	Standard
Oven capacity (cu. ft.)	3.0	3.0	2.4	2.4
Oven racks	2	2	2	2
Recessed lift-up cooktop	●	●	●	●
Porcelain-enameled subtop	●	●	●	●
8-inch heating elements	1 plug-in	1 plug-in	1 plug-in	1 plug-in
6-inch heating elements	3 plug-in	3 plug-in	3 plug-in	3 plug-in
Removable drip bowls	Chrome	Chrome	Chrome	Chrome
Push-to-turn controls	●	●	●	●
Heating element "ON" indicator lights	2	2	2	2
Oven cycling light	●	●	●	●
Interior oven light	●	●	●	●
In-oven broiling	●	●	●	●
Broiler pan with grid	●	●	●	●
<b>Appearance</b>				
Color appearance*	WW	WH	WW	WH, CT
Oven door with window	●	●	●	●
Porcelain-enameled oven door	●	●*	●	●*
Four leveling legs	●	●	●	●
<b>Weights and Dimensions</b>				
Overall oven interior dimensions (W x H x D in inches)	20 x 15 x 16-1/4		16 x 15 x 16-1/4	
Approx. ship. wt. (lbs.)	139	139	126	126
<b>Power/Ratings</b>				
KW rating @ 240V	9.2	9.2	9.2	9.2
@ 208V	6.9	6.9	6.9	6.9
Broiler/bake wattage	3000/2700	3000/2700	3000/2700	3000/2700

\*WW=White with white door, WH=White with color-matched door, CT=Bisque with color-matched door.

## 24" and 20" free-standing range installation information (inches)

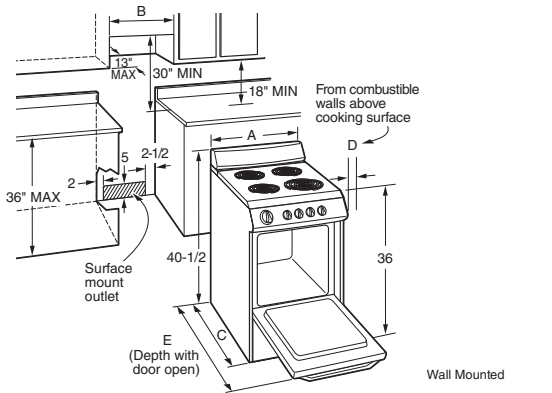

Note: 24" Ranges conform to UL requirements for 0" spacing from range to adjacent walls below countertop.

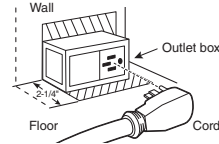

Recommended acceptable electrical outlet area. Orient the electrical receptacle so the length is parallel to the floor.

## 24" and 20" free-standing electric range dimensions (inches)

Models	A	B	C	D	E
20" wide	20	20-3/8	23.15	2	41
24" wide	24	24-3/8	23.15	2	41

24" and 20" gas ranges	24" range RGA824DED	24" range RGA724EK	20" range RGA820DED	20" range RGA720EK
<b>Features</b>				
ADA compliant	●	●	●	●
Oven cleaning	Standard	Standard	Standard	Standard
Oven capacity (cu. ft.)	3.0	3.0	2.4	2.4
Oven racks	2	2	2	2
Recessed lift-up cooktop	●	●	●	●
Porcelain-enameled subtop	●	●	●	●
Continuous grates	●	●	●	●
Ignition system	Electronic	Electronic	Electronic	Electronic
Push-to-turn controls	●	●	●	●
Interior oven light	●	●	●	●
Broiler pan with grid	●	●	●	●
Separate broiler drawer (with tip-down door)	●	●	●	●
<b>Appearance</b>				
Color appearance*	WW	WH	WW	WH
Oven door with window	●	●	●	●
Porcelain-enameled oven door	●	Solid CM	●	Solid CM
Removable oven door	●	●	●	●
Four leveling legs	●	●	●	●
<b>Weights and Dimensions</b>				
Overall oven interior dimensions (WxHxD in inches)	20 x 15 x 16-1/4	20 x 15 x 16-1/4	16 x 15 x 16-1/4	16 x 15 x 16-1/4
Approx. ship. wt. (lbs.)	142	142	132	132
<b>Power/Ratings</b>				
Burner BTU:				
Top (Nat/LP)	(4) 9,100/8,000	(4) 9,100/8,000	(4) 9,100/8,000	(4) 9,100/8,000
Oven (Nat/LP)	13,000/13,000	13,000/13,000	13,000/13,000	13,000/13,000
Gas range electrical rating**	120V, 60 Hz, 5A	120V, 60 Hz, 5A	120V, 60 Hz, 5A	120V, 60 Hz, 5A

\*WW=White with white door, WH=White with color-matched door, CM=Indicates color of oven door matches range cooktop.  
\*\*Factory set for natural gas. Can be converted to LP by a qualified technician.

## 24" gas range dimensions and installation information (inches)

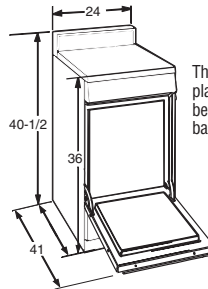

## 20" gas range dimensions and installation information (inches)

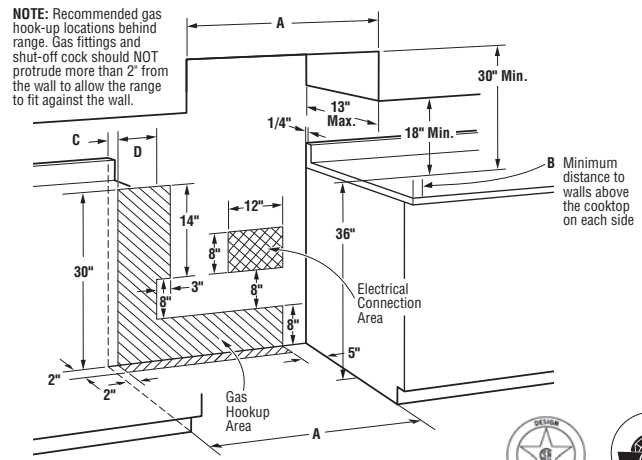
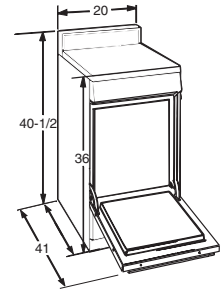

All Hotpoint ranges are equipped with an Anti-Tip device. The installation of this device is an important, required step in the installation of the range.



**Installation information:** Before installing, consult installation instructions packed with product for current dimensional data.

Above illustrations intended for dimensional reference only. Refer to photography for actual product appearance.

See page 30 for warranty information.

# HOOD SPECIFICATIONS

Width	Standard
24"	RN328H
30"	
36"	

## Hood

Features	
Two-speed fan control	●
Removable grease filters	Disposable 1-Pc. Filter†
Filter size (sq. in.)	90
Cooktop light(s)*	1
Non-vented	●
Appearance	
Color appearance**	SA
Weights & Dimensions	
Approx. shipping weight (lbs.)	19
Power/Ratings	
Current rating amps @ 120V	2.5

\*Light bulbs not furnished.

\*\*SA=Silver metallic.

†WB2X8391 replacement grease filter and WB02X10700 replacement charcoal filter are available for additional cost. Call toll-free 800.626.2002.

## Dimensions (in inches)

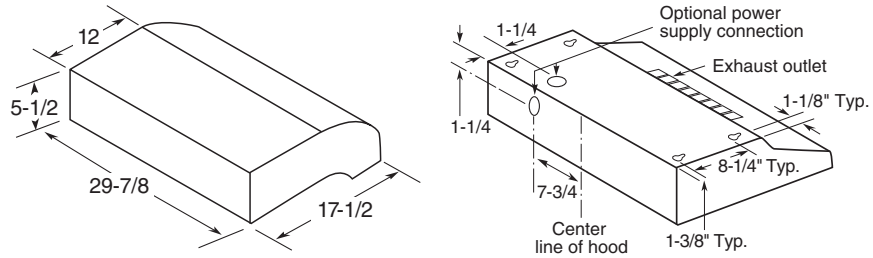

# MICROWAVE OVEN SPECIFICATIONS

## Over-the-range microwave oven

	RVM5160RH RVM5160DH
Capacity	
Capacity (cu. ft.)	1.6
Watts (IEC-705 Test Procedure)	1000
Cooking modes	●
Factory set recirculation	Vented
Controls	
Convenience controls	
Beverage	●
Cook time	●
Defrost: Weight/Time	●
Popcorn	●
Potato	●
Reheat	●
Controls Touchpad	
Add 30 seconds	●
Electronic touch controls	●
Oven	
Interior/cooktop lighting	Incandescent
Turntable	●
Turntable diameter (in.)	13-1/2
Appearance	
Color appearance*	SS WW, CC, BB
Case color*	BB WW, CC, BB
Handle color*	BB CM
Handle design	Designer-style
Oven interior	Epoxy white
Touchpad	BB WW, CC, BB
Weights & Dimensions	
Overall oven interior dimension WxHxD (in inches)	20-1/4 x 9-1/4 x 14-13/32
Approx. shipping weight (lbs.)	66
Power/Ratings	
Exhaust vent fan	200 CFM
Input Volt/Hertz	120/60
Input Amps/Watts (max)	15/1580
Accessories	
Recirculating charcoal filter kit (optional)	JX81L
15" cabinetry bump out kit	JX15BUMPWW/BB

\*SS=Stainless steel, WW=White on white, CC=Bisque on bisque, BB=Black on black, CM=Color-matched.

## Dimensions (in inches)

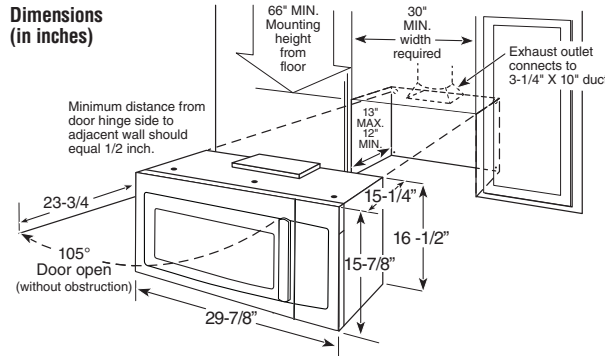

## Overall exterior dimensions (in inches)

Models	W	D	H	H (Rear)
RVM1560	29-7/8	15-1/4	15-7/8	16-1/2

**Important:** When installing the microwave oven over a range, allow minimum of 2" from bottom of microwave oven to top of range backguard to allow for removal of light covers.

## Optional Accessories (Available at additional cost)

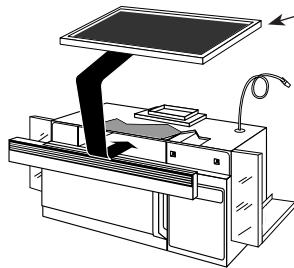

**JX81L-Recirculating Charcoal Filter Kit**  
To be used when the microwave oven cannot be vented to the outside.

## Ventilation options

The microwave oven is designed for adaptation for the following three types of ventilation:

- Outside Exhaust** (Vertical – Delivered from factory in vertical position)
- Outside Exhaust** (Horizontal)
- Recirculating** (Non-vented ductless)

**Installation information:** This information is not intended to be used for installing unit described. Before installing, consult installation instructions packed with product/kit for current dimensional data.



# DISHWASHER SPECIFICATIONS

Built-in dishwashers	HDA3600H	HDA2100H	HDA2160H
<b>ENERGY STAR® qualified</b>	●		●
Energy Factor (EF)	0.73	0.70	0.70
Normal wash gallons per cycle*	4.25	5	5
Kilowatt hours/year	295	307	307
<b>Features</b>			
Wash levels	5	4	4
2-stage filtration	●	●	●
Self-cleaning filter	●	●	●
Hand-food disposer	Piranha™	Piranha	Piranha
Cycles/Options	5/3	5/2	5/2
Pots & Pans cycle	●		
Heavy Wash cycle	●	Dial	Dial
Normal Wash cycle	●	Dial	Dial
Water Saver cycle		Dial	Dial
Plate Warmer cycle	Dial	Dial	Dial
Rinse Only cycle	Dial	Dial	Dial
Heated Dry	●	Rocker	Rocker
Hi-Temp Wash	●		
Control type	Turn-to-start	Dial w/Rocker	Dial w/Rocker
Touchpads	6		
Cycle progress indicator	Dial	Dial	Dial
Rack	Deluxe	Standard	Standard
Silverware basket	Deluxe	Deluxe	Deluxe
Solid surface install kit	GPF65	GPF65	GPF65
Rinse aid dispenser	●	●	●
Door latch	Center-throw	Center-throw	Center-throw
<b>Quiet</b>			
Sound insulation package**	62 dBA	64 dBA	64 dBA
Tub insulation—blanket	●		
<b>Appearance</b>			
Color appearance†	WW/BB	WW/CC/BB	SS
Color panels	Door	Trimless	Trimless
Access	Trimless	Trimless	Trimless
<b>Weights &amp; Dimensions</b>			
Height w/legs retracted (in.)	34	34	34
Overall width (in.)	24	24	24
Overall depth (in.)	25-3/4	25-3/4	25-3/4
Approx. shipping wt. (lbs.)	70	70	70

\*Based on DOE test procedure, ANSI/AHAM DW-1.

\*\*dBA levels based on Owens-Corning IEC-60704 lab testing, 2009-2010.

†SS=Stainless steel, WW=White on white, CC=Bisque on bisque, BB=Black on black.



Dimensions (in inches)

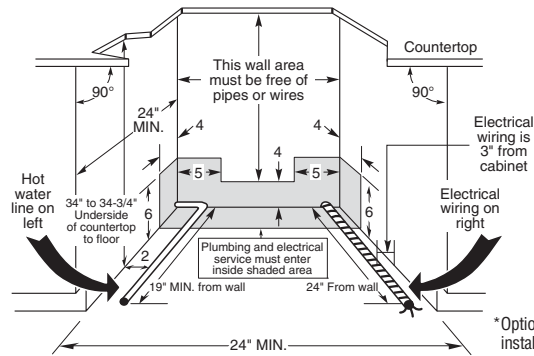
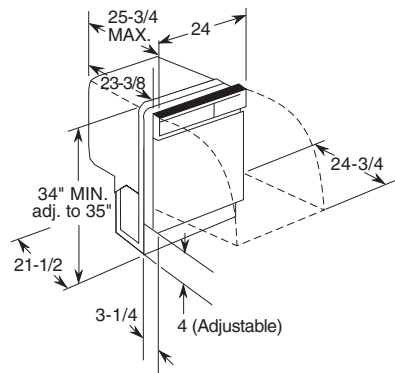

\*Optional kit required (GPF10S) for installation 6-10 feet from sink.

**Specifications and electrical rating**

120 Volts AC, 60 Hertz, 6.2 Amps total connected load 500-Watt Calrod® heater. For use on adequately wired 120-volt, 15-amp circuit having two-wire service with a separate ground wire. This appliance must be grounded for safe operation. Dishwasher must not be installed more than 10 feet from sink for proper drainage.\* All plumbing and electrical work must be in accordance with local codes. Dishwasher includes drain hose and leveling legs.

Dishwasher accessories	Plastic Standard Tub	Convertibles	18" Dishwashers	Under-The-Sink Dishwashers
GPF65—6' power cord	●		●	●
GPF10L—10' drain hose for tall tub			●	
GPF10S—10' drain hose for standard tub	●			
GPF65—solid surface installation kit	●			
WD35M34—convertible-to-built-in conversion kit		●		

**Installation information:** Before installing, consult installation instructions packed with product for current dimensional data.

# CLOTHES CARE SPECIFICATIONS

Washers	HTWP1400F	HSWP1000M
<b>Capacity</b>		
Capacity cu. ft.	3.7 DOE*	3.5 DOE*
<b>Controls</b>		
Rotary	●	●
Wash/rinse temps	3	3
Water levels	4	3
<b>Wash system</b>		
Wash basket	Extra Action	Extra Action
Wash mechanism	Dual-action agitator	Dual-action agitator
Wash/spin combinations	2	2
<b>Drive system</b>		
Transmission	Steel	Steel
Maximum spin speed	630 RPM	630 RPM
<b>Dispensers</b>		
Bleach	●	●
Fabric Softener	●	
<b>Wash cycles</b>		
Number of cycles	8	8
<b>Cottons regular</b>	Whites	Whites
Heavy soil	●	●
Light soil	●	●
<b>Easy care</b>		Casuals
Heavy soil		●
Light soil		●
<b>Colors</b>		
Heavy soil	●	●
Light soil	●	●
<b>Special cycles</b>		
Drain & Spin	●	●
Permanent Press	●	
Rinse & spin (Quick rinse)	●	●
Spin only	●	●
<b>Additional features</b>		
Power Rinse	●	
Quiet performance	Quiet-by-Design	Quiet-by-Design
Instructions/guides	Color lid instructions	Color lid instructions
<b>Appearance</b>		
Colors available**	WW	WW
<b>Weights &amp; dimensions</b>		
Approx. shipping weight (lbs.)	152	152
H x W x D in inches	42 x 27 x 25-1/2	42 x 27 x 25-1/2

\*Department of Energy.  
\*\*WW = White on white.

## Washer dimensions (in inches)

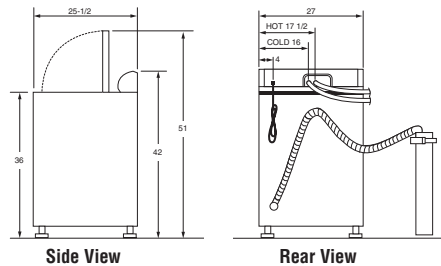

## Washer specifications:

**Electrical rating:** 115V, 60 Hz, 10 Amps

**Circuit requirements:** An individual properly grounded branch circuit, with a three-prong grounding-type receptacle protected by a 15- or 20-amp circuit breaker or time-delay fuse, is required.

**Washer Note:** Washer wall outlet must be located within 36" of service cord entry. Wall outlet must not be located behind dryer.

**Dryer Note:** Dryer wall outlet must be located within 36" of service cord entry and accessible when dryer is mounted in position.



Dryers	Electric	HTDP120ED	HTDX100ED	HTDX100EM
	Gas	HTDP120GD	HTDX100GD	HTDX100GM
<b>Capacity</b>				
Capacity cu. ft.		6.8	6.0	6.0
<b>Controls</b>				
Rotary		●	●	●
Heat selections		4	3	3
<b>Dry system</b>				
Temperature sensor		Thermostat	Thermostat	Thermostat
Dryer drum		Dura Drum	Dura Drum	Dura Drum
Drum baffles		White	White	White
<b>Dry cycles</b>				
Number of cycles		6	4	3
<b>Cottons regular</b>				
Automatic dry cottons		●	●	●
<b>Easy care</b>				
Automatic dry easy care		●	●	●
<b>Timed dry</b>				
Maximum time available		80 mins.	80 mins.	80 mins.
<b>Additional features</b>				
Quiet performance		Quiet-by-Design	Quiet-by-Design	Quiet-by-Design
Upfront lint filter		●	●	●
<b>Appearance</b>				
Colors available*		WW	WW	WW
<b>Weights &amp; dimensions</b>				
Approx. shipping weight – elect.		109	102	102
Approx. shipping weight – gas		111	105	105
H x W x D in inches		42 x 27 x 28-1/4**	42 x 27 x 25-1/2**	42 x 27 x 25-1/2**
LP conversion kit (sold separately)		WE25X0217	WE25X0217	WE25X0217

\*WW = White on white.

\*\*24-1/2" from the edge of the side panel to the front. 25-1/2" from front to edge of endcaps.

## Dryer dimensions (in inches)

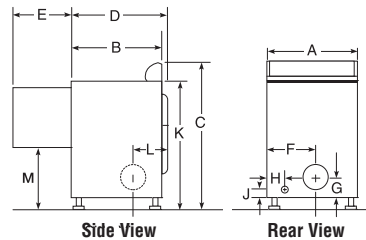

## Dryer Specifications

### Exhaust Options:

**Electric:** 4-way via rear, right, left and bottom.

**Gas:** For 6.0 and 6.8 cu. ft. dryers, when viewed from the front of the unit, exhaust 3-way via rear, left and bottom. Dryer is shipped exhausted to the rear. Alternate exhausting knockouts are supplied.

	6.0 Capacity	6.8 Capacity
A	27	27
B	25-1/2*	28-1/4
C	42	42
D	25-3/4	25-3/4
E	23-1/2	23-1/2
F	11-1/2	11-1/2
G	3-1/2	3-1/2
H	2	2
J	2-1/2	2-1/2
K	36	36
L	5-1/4	5-1/4

\*24-1/2" from the edge of the side panel to the front.  
25-1/2" from front to edge of endcaps.

## Power Cord Locations

6.0 cu. ft. dryers

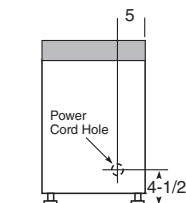

## Circuit requirements:

**Electric:** An individual properly grounded branch circuit protected by a 30-amp circuit breaker or time-delay fuse, is required.

**Gas:** An individual, properly grounded branch circuit with a three-prong grounding-type receptacle, protected by a 15- or 20-amp circuit breaker or time-delay fuse, is required.

**Gas (BTU/HR):** 22,000 for 6.0 and 6.8 cu. ft. dryers. Factory-equipped for natural gas. Tested for LP gas. LP gas supply requires an optional conversion kit: 5.8, 6.0 and 6.8 cu. ft. model kit is WE25X0217. Have a qualified gas technician install a conversion kit. See dryer ducting information for proper installation.

**Electric dryer rating:** 240V, 5600W, 24A, 60 Hz–6.0, 6.8 cu. ft. dryers. 208V, 4400W, 22A, 60 Hz–6.0, 6.8 cu. ft. dryers

**Gas dryer electric rating:** 120V, 60 Hz, 6A

**Installation information:** Before installing, consult installation instructions packed with product for current dimensional data.

## Dryer Exhausting Information

For complete information see installation instructions packed with dryer.

### Important note:

6.0 cu. ft. dryers require additional parts to convert to side venting. GTUP240EM/GM does not require a kit for side venting.

### Ducting materials

For best performance, this dryer should be vented with 4" diameter all-rigid-metal exhaust duct. If rigid metal duct cannot be used, then UL® listed flexible metal (semi-rigid) ducting can be used (Kit PM08X10084). In special installations, it may be necessary to connect the dryer to the house vent using a flexible metal (foil-type) duct. A UL® listed flexible metal (foil-type) duct may be used ONLY in installations where rigid metal or flexible metal (semi-rigid) ducting cannot be used AND where a 4" diameter can be maintained throughout the entire length of the transition duct. Please see installation instructions packed with your dryer for complete instructions when using flexible metal (foil-type) ducting.

See installation instructions for complete information.

### Exhaust length calculation:

- Determine the number of 90° turns needed for your installation. If you exhaust to the side or bottom of dryer, add one turn.
- The maximum length of 4" rigid (aluminum or galvanized) duct which can be tolerated is shown in the table. A turn of 45° or less may be ignored. Two 45° turns within the duct length should be treated as a 90° elbow. A turn over 45° should be treated as a 90° elbow.

Dryers **must** be exhausted to the outside.

**Caution:** For personal safety do not terminate exhaust into a chimney, under any enclosed house floor (crawl space), or into an attic, since the accumulated lint could create a fire hazard or moisture could cause damage. Never terminate the exhaust into a common duct or plenum with a kitchen exhaust, since the combination of lint and grease could create a fire hazard.

Exhaust ducts should be terminated in a dampered wall cap to prevent back drafts, bird nesting, etc. The wall cap must also be located at least 12" above the ground or any other obstruction with the opening pointed down.

## Special Installation Requirements

### Alcove or closet installation:

- If your dryer is approved for installation in an alcove or closet, it will be stated on a label on the dryer back.
- The dryer **MUST** be exhausted to the outdoors. See EXHAUST INFORMATION above and installation instructions.
- Minimum clearances between dryer cabinet and adjacent walls or other surfaces are:
  - 0" either side
  - 3" front and rear
- Minimum vertical space from floor to overhead cabinets, ceilings, etc. is 52".
- Closet doors must be louvered or otherwise ventilated and must contain a minimum of 60 sq. in. of open area equally distributed. If this closet contains both a washer and a dryer, doors must contain a minimum of 120 sq. in. of open area equally distributed.
- The closet should be vented to the outdoors to prevent gas pocketing in case of a gas leak in the supply line.
- No other fuel-burning appliance shall be installed in the same closet with the dryer.

### Bathroom or bedroom installation:

- The dryer **MUST** be exhausted to the outdoors. See installation instructions.
- The installation must conform with the local codes, or in the absence of local codes, with the National Electric Code, NFPA70, and National Fuel Gas Code, NFPA54, for gas dryers.

### Minimum clearances other than alcove or closet installations

- Minimum clearances to combustible surfaces:
  - 0" both sides
  - 3" rear

For more information on venting kits and accessories, please call 1-800-GE-CARES.

## Dryer Exhausting Information—Use Metal Duct Only Vertical and Horizontal Ducting

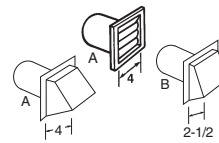

	Number of 90° Turns	Best Performance	
		A 4" opening	B 2-1/2" opening
Domestic dryer models	0	90 ft.	60 ft.
All 6.0 - 6.8 cu. ft. capacity models electric and gas dryers (HTDP, HTDX)	1	60 ft.	45 ft.
	2	45 ft.	35 ft.
	3	35 ft.	25 ft.
	4	25 ft.	15 ft.



Listed by Underwriters Laboratories



# WARRANTIES\*

The condensed list below is a convenient overview of the written warranties offered on various Hotpoint® appliances described in this catalog for products manufactured on or after January 1, 2006. For complete warranty details on a specific appliance model, contact your nearest Hotpoint appliance dealer/distributor, or call GE Factory Service, toll-free, 800-GE-CARES (800-432-2737).

## REFRIGERATORS AND FREEZERS

For the period of	GE will replace
<b>One year</b> From the date of the original purchase	<b>Any part</b> in the refrigerator which fails due to a defect in materials or workmanship. During this <b>limited one-year warranty</b> , GE will provide, <b>free of charge</b> , all labor and related service costs to replace the defective part.

## RANGES

For the period of	GE will replace
<b>One year</b> From the date of the original purchase	<b>Any part</b> in the cooking product which fails due to a defect in materials or workmanship. During this <b>limited one-year warranty</b> , GE will provide, <b>free of charge</b> , all labor and related service costs to replace the defective part.

## MICROWAVE OVENS

For the period of	GE will replace
<b>One year</b> From the date of the original purchase	<b>Any part</b> in the microwave which fails due to a defect in materials or workmanship. During this <b>limited one-year warranty</b> , GE will provide, <b>free of charge</b> , all labor and related service costs to replace the defective part.

## DISHWASHERS

For the period of	GE will replace
<b>One year</b> From the date of the original purchase	<b>Any part</b> in the dishwasher which fails due to a defect in materials or workmanship. During this <b>limited one-year warranty</b> , GE will provide, <b>free of charge</b> , all labor and related service costs to replace the defective part.

## WASHERS

For the period of	GE will replace
<b>One year</b> From the date of the original purchase	<b>Any part</b> in the washer which fails due to a defect in materials or workmanship. During this <b>limited one-year warranty</b> , GE will provide, <b>free of charge</b> , all labor and related service costs to replace the defective part.

## DRYERS

For the period of	GE will replace
<b>One year</b> From the date of the original purchase	<b>Any part</b> in the dryer which fails due to a defect in materials or workmanship. During this <b>limited one-year warranty</b> , GE will provide, <b>free of charge</b> , all labor and related service costs to replace the defective part.

## PARTS AND ACCESSORIES

For the period of	GE will replace
<b>One year</b> From the date of the original purchase	<b>Any part or accessory</b> which fails due to a defect in materials or workmanship. During this <b>limited one-year warranty</b> , GE will provide, <b>free of charge</b> , all labor and related service costs to replace the defective part.

# ADA REQUIREMENTS\*\*

## Refrigerator/Freezers

Regulation #/Description:

**4.2.6 Side Reach\***—If the clear floor space allows parallel approach by a person in a wheelchair, the maximum high side reach allowed shall be 54 in. (1370 mm) and the low side reach shall be no less than 9 in. (230mm) above the floor. **4.27.4 Operation**—Controls and operating mechanisms shall be operable with one hand and shall not require tight grasping, pinching, or twisting of the wrist. The force required to activate controls shall be no greater than 5lbf (22.2 N). **4.34.6.8**

**Refrigerator/Freezer**—Refrigerator/freezers shall comply with 4.34.6.3. Provision shall be made for refrigerators which are: (1) Of the vertical side-by-side refrigerator/freezer type; OR (2) Of the over-and-under type and meet the following requirements: (a) Have at least 50 percent of the freezer space below 54 in (1370 mm) above the floor. (b) Have 100 percent of the refrigerator space and controls below 54 in (1370 mm).

## Free-standing ranges—gas & electric

Regulation #/Description:

**4.2.5**—maximum high forward reach for controls and operating mechanisms is 48", minimum low forward reach is 15"; **4.27.4**—controls and operating mechanisms must be operable with one hand and shall not require tight grasping, pinching, or twisting of the wrist. The force required to activate controls shall be no more than 5lbf; **4.34.6.6**—if ovens or cooktops have knee spaces underneath then they shall be insulated or otherwise protected on the exposed surfaces to prevent burns, abrasions, or electrical shock. The location of controls for ranges and cooktops shall not require reaching across burners.

## Microwave ovens\*\*\*

Regulation #/Description:

**4.2.5**—maximum high forward reach for controls and operating mechanisms is 48", minimum low forward reach is 15"; **4.27.4**—controls and operating mechanisms must be operable with one hand and shall not require tight grasping, pinching, or twisting of the wrist. The force required to activate controls shall be no more than 5lbf.

## Dishwashers

Regulation #/Description:

**4.2.5**—maximum high forward reach for controls and operating mechanisms is 48", minimum low forward reach is 15"; **4.27.4**—controls and operating mechanisms must be operable with one hand and shall not require tight grasping, pinching, or twisting of the wrist. The force required to activate controls shall be no more than 5lbf; **4.34.6.9**—all rack space shall be accessible from the front of the machine for loading and unloading dishes.

## Laundry

Regulation #/Description:

**4.2.5**—maximum high forward reach for controls and operating mechanisms is 48", minimum low forward reach is 15"; **4.2.6 Side Reach\***—If the clear floor space allows parallel approach by a person in a wheelchair, the maximum high side reach allowed shall be 54 in. (1370 mm) and the low side reach shall be no less than 9 in. (230mm) above the floor; **4.27.4**—controls and operating mechanisms must be operable with one hand and shall not require tight grasping, pinching, or twisting of the wrist. The force required to activate controls shall be no more than 5lbf; **4.34.7.2**—washing machines and clothes dryers shall be front loading.

GE has a policy of continuous improvement of its products and reserves the right to change materials and specifications without notice.

\*\*ADA qualified based on Uniform Federal Accessibility Standards.

\*\*\*ADA compliant in the built-in configuration.

**EXCLUSION OF IMPLIED WARRANTIES** — Your sole and exclusive remedy is product repair as provided in this Limited Warranty. Any implied warranties, including the implied warranties of merchantability or fitness for a particular purpose, are limited to one year or the shortest period allowed by law.

# GE HAS BUILDERS' BACKS

## Rave reviews. Resources. Support.

There are countless reasons to feel great about having GE® appliances in your homes.

In the 2014 Builder Magazine Awards, GE received honors in ALL FIVE major appliance product categories: Ranges & Cooktops, Range Hoods, Dishwashers, Refrigerators and Laundry.

## Access the tools of the trade at [buildwithge.com](http://buildwithge.com)

All the resources and tools you need in one user-friendly website.

- View quick specs, installation info, CAD 20-20 downloads and more
- Compare different GE brands
- Create a new kitchen in the Kitchen Design Center
- Build customized brochures for homeowners
- Look up parts and service information

**#1 CHOICE OF HOME BUYERS\***

**GREENEST APPLIANCE PRODUCTS\*\***

**TOP SUSTAINABLE BRAND\*\*\***

**TOP-OF-MIND GREEN APPLIANCE BRAND BY BUILDERS AND REMODELERS†**

**BEST GLOBAL GREEN BRANDS††**

**BEST GLOBAL BRANDS††**

\*Source: Lifestory® Research 2012 Residential New Home Shopper Brand Survey

\*\*Green Builder Magazine, 2014 Reader's Choice Brand Survey

\*\*\*Green Builder Magazine, 2012 Readers Choice Brand Study

†2012 SmartMarket Report—McGraw-Hill

††Interbrand, 2014

**THANK YOU**  
FOR SUPPORTING AMERICAN JOBS



Many GE appliances contain 70 to 90% U.S. content and are designed, engineered and built by employees in eight U.S. factory locations. So when you buy GE, you're investing in the livelihood of communities right here at home.



**MADE IN AMERICA**

70 to 90% U.S. content. Product content details at [GEAppliances.com/USA](http://GEAppliances.com/USA)

# NOMENCLATURES

## Top-freezer refrigerator nomenclature

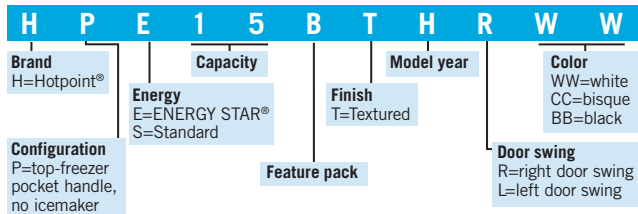

## Dishwasher nomenclature

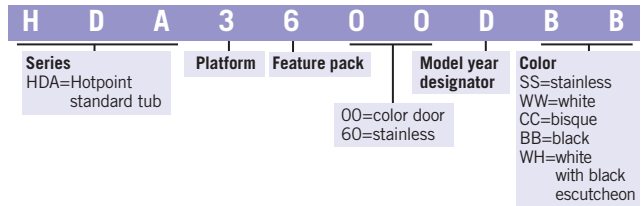

## Side-by-side refrigerator nomenclature

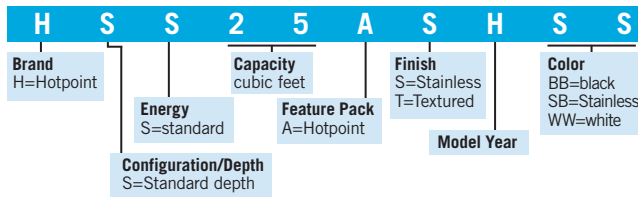

## Washer nomenclature

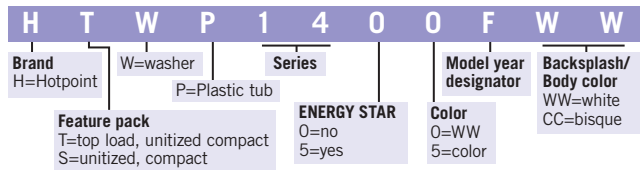

## Cooking products nomenclature

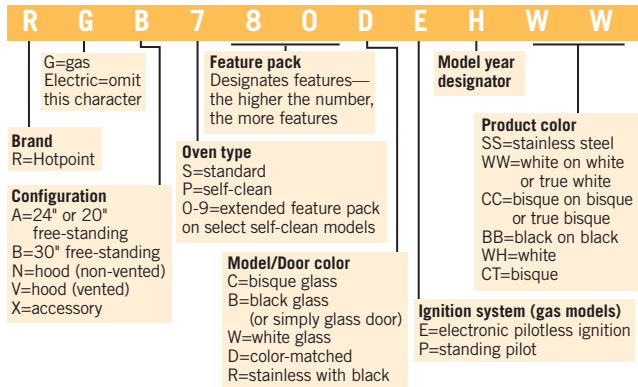

## Dryer nomenclature

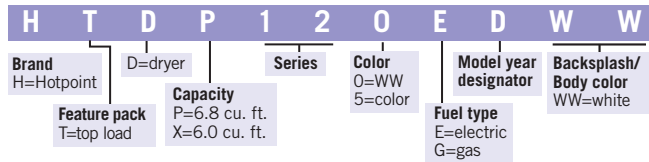

## Microwave oven nomenclature

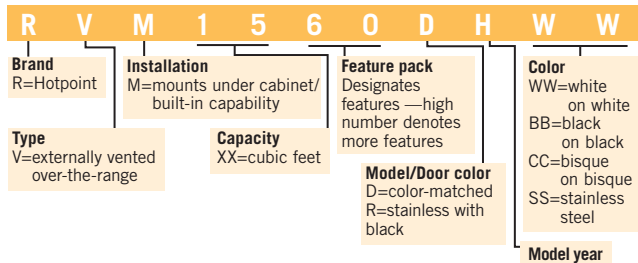



## PARTS AND ACCESSORIES

### STAINLESS STEEL MAINTENANCE

Citrushine™ stainless steel wipes	WX10X10007
Citrushine stainless steel spray	WX10X10008
Cerama Bryte® microfiber cleaning cloths	WX10X306

### REFRIGERATION

GE® premium replacement water filter	MWF
Ice machine cleaner	WX08X42870
Freezer utility shelf	WR71X2086
GE icemaker kit	IM6D
GE SmartConnect™ tubing for icemakers— 6' length	WX08X10006G
GE SmartConnect tubing for icemakers— 15' length	WX08X10015
15' copper water line	PM8X1
Appliance brush set	PM14X10056
Cerama Bryte® refrigerator cleaner	WX10X10206
Cerama Bryte touchup spray	WX10X391
40-watt appliance light bulb	40A15RVL

### COOKING

Cerama Bryte complete cooktop kit	WX10X10020
Cerama Bryte gas grate cleaning kit	WX10X10021
48" universal gas range install kit	PM15X103
Cerama Bryte cooktop scraper	WX10X302
Cerama Bryte microfiber cleaning cloths	WX10X306
Cerama Bryte burnt-on grease remover	WX10X320
Cerama Bryte cleaning pads	WX10X350
Cerama Bryte touchup spray	WX10X391
Broiler pan/rack set (12-3/4" x 16-1/2")	WB48X10056G
4' 3-wire 40-amp electrical range cord	WX09X10006
4' 4-wire 40-amp electrical range cord	WX09X10035
Cerama Bryte glass-ceramic cooktop cleaner	WX10X300
Cerama Bryte ceramic cooktop scraper and pad	PM10X304

### MICROWAVE OVENS

Micro Bryte® microwave/appliance cleaner	WX10X3092
--	-----------

### DISHWASHERS

12' dishwasher connector kit with adapter	WX28X327
Universal 6' dishwasher connector kit with adapter	PM28X326
10' drain hose and universal connector kit (tall tub)	WX28X320
10' drain hose and universal connector kit (standard tub)	WX28X321
Citric acid cleaner	WD35X151
Lemi Shine® cleaner and deodorizer	WX10X10019
Dishwasher power cord	WD06X10020

Citrushine is a trademark of Bryson Industries, Inc. Cerama Bryte is a registered trademark of Cerama Bryte, Inc. Micro Bryte is a registered trademark of Golden Ventures, Inc. Lemi Shine is a registered trademark of Envirocan Technologies, Inc. Washer Magic is a registered trademark of Summit Brands.

### CLOTHES CARE

4' rubber washer hose, 2-pack	PM14X10002
4' stainless steel washer hose, 2-pack	PM14X10005
Appliance brush set	PM14X10056
Universal flexible metal dryer duct kit	PM08X10085
Universal 48" gas dryer installation kit	PM15X104
6' 4-wire 30-amp electrical dryer cord	WX09X10020
6' 3-wire 30-amp electrical dryer cord	WX09X10004
Washer Magic® cleaner	WX10X10208
Anti-vibration pads	WX17X10001CA
Dryer rack	WE1M1038 WE1M396 WE01X10410
Low-profile universal washer floor tray	PM7X2-White PM7X3-Metallic carbon



### Warranty Information

All parts and accessories have a limited one-year warranty, with the exception of water filters, which have a 30-day warranty.

#### Limited One-Year Warranty

If your GE part fails because of a manufacturing defect within one year from the date of original purchase, we will provide a new or, at our option, rebuilt part without charge. Return the defective part to the vendor from whom it was purchased with a copy of the "proof of purchase." If the part is defective it will be exchanged. This warranty does not cover parts which are improperly installed, damaged, abused or used for other than the intended purpose. It does not include cost of returning the part to the vendor from which it was purchased, labor to remove, install or diagnose the failure, parts used in commercial applications, incidental or consequential damage caused by possible defects with the parts.



What's the point of  
a good product if  
you don't have support  
when you  
need it?

If you need us, we're here. Our goal is to ensure your satisfaction, while offering the highest levels of professional service at affordable and competitive rates.

#### ONLINE RESOURCES

**Hotpoint.com** – Schedule service, get model information or browse our products

**BuildWithGE.com** – Support, resources and innovative products for builders

**GEAppliances.com** – Check out GE's entire appliance selection

**GECustomerNet.com** – Place orders and check pricing, availability, product specifications and more

#### BY PHONE

**GE Cares** – A nationwide network of sales professionals and service technicians wholly dedicated to the builder community. 1-800-GEcares (1-800-432-2737)

**GE Answer Center®** – Save time by getting answers on product features. 1-800-626-2005

# Hotpoint®

Hotpoint has a policy of continuous improvement on its products and reserves the right to change materials and specifications without notice.