

# HOTPOINT®

## HTS17BCM – Hotpoint 16.9 Cu. Ft. Top-Freezer Refrigerator

Front View

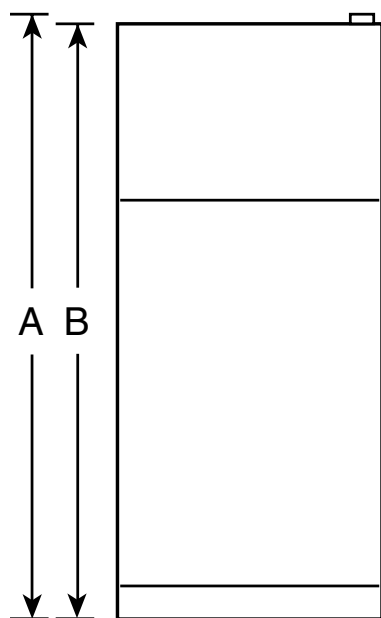

Top View

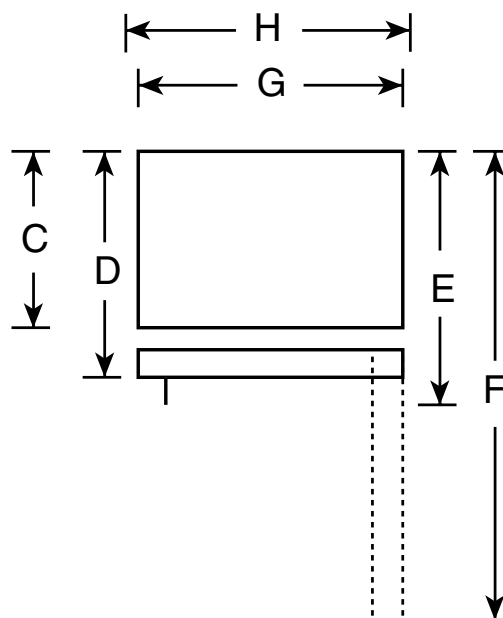

Overall Dimensions	Height with hinge (in.) <b>A</b>	<b>67-3/8</b>
	Height without hinge (in.) <b>B</b>	<b>66-7/8</b>
	Depth without doors (in.) <b>C</b>	<b>26-3/4</b>
	Depth with doors (in.) <b>D</b>	<b>30</b>
	Depth plus handle with doors closed (in.) <b>E</b>	<b>31-7/8</b>
	Depth with doors open 90° (in.) <b>F</b>	<b>55-3/4</b>
	Width with doors closed (in.) <b>G</b>	<b>28</b>
	Width with door open 90° less door handle (in.) <b>H</b>	<b>28-5/8</b>
Air Clearances	Each side (in.)	<b>3/4</b>
	Top (in.)	<b>1</b>
	Back (in.)	<b>1</b>

**Note:** Before installing, consult installation instructions packed with product for current dimensional data.



# HOTPOINT®

## HTS17BCM – Hotpoint 16.9 Cu. Ft. Top-Freezer Refrigerator

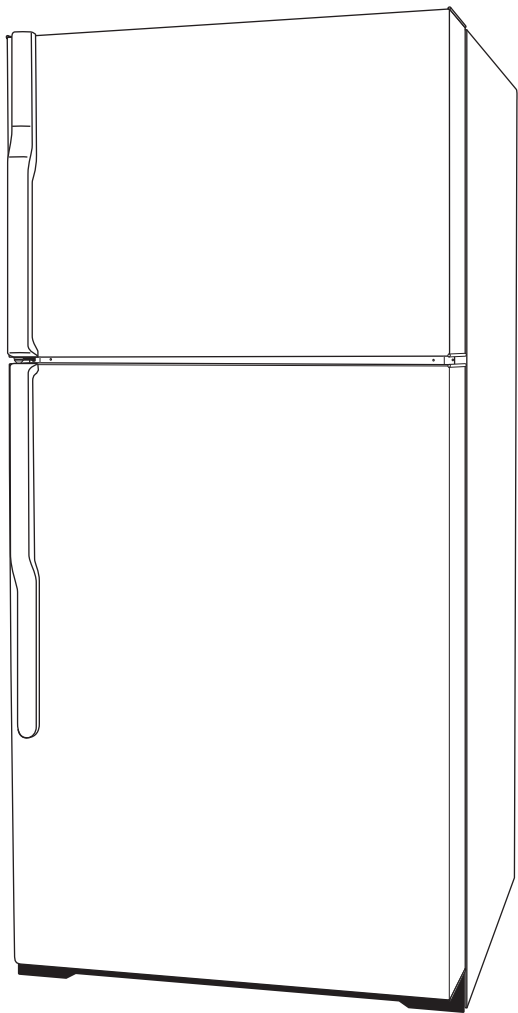

### Features and Benefits

- 16.9 cu. ft. Capacity (Fresh Food 13.05 cu. ft./Freezer 3.86 cu. ft.)
- Equipped with Factory-Installed Automatic Icemaker
- 2 Vegetable/Fruit Crispers
- 2 Adjustable Full-Width Wire Everwhite Fresh Food Cabinet Shelves
- 2 Fresh Food Door Shelves with Tall Bottle Storage
- Dairy Compartment
- 2 Fixed Freezer Door Shelves
- Ice Storage Bin
- Deluxe Quiet Design Quiet Package
- Color-Matched Door Handles
- Model HTS17BCMWW – White on white
- Model HTS17BCMCC – Bisque on bisque