

HOTPOINT®

HTS18JBN – Hotpoint 17.9 Cu. Ft. Top-Freezer Refrigerator

Front View

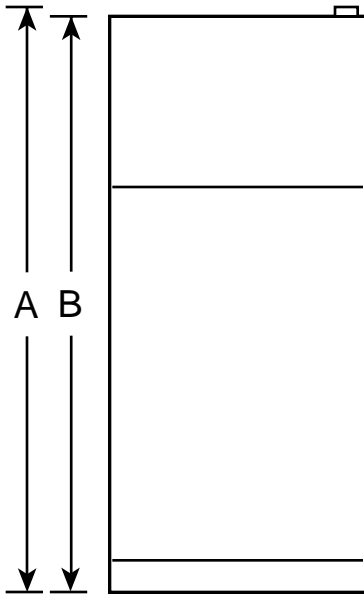

Top View

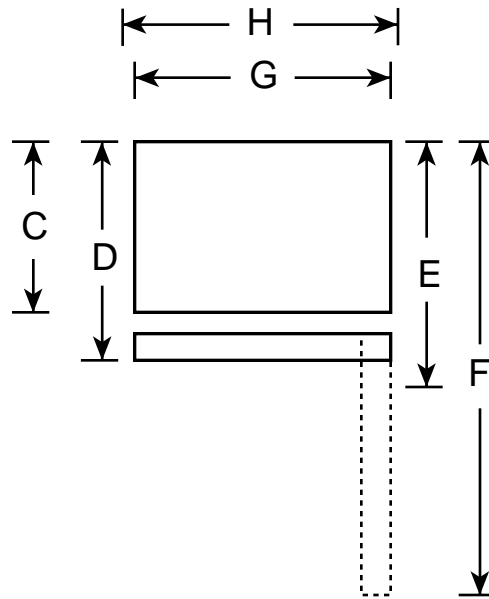

Overall Dimensions	Height to top of hinge (in.) A	66-5/8
	Height to top of case (in.) B	66-1/8
	Case depth without door (in.) C	27-1/2
	Case depth less door handle (in.) D	30-1/4
	Case depth with door handle (in.) E	32-1/8
	Depth with fresh food door open 90° (in.) F	58-1/8
	Width (in.) G	29-1/2
	Width with door open 90° less door handle (in.) H	30
Air Clearances	Each side (in.)	1/8
	Top (in.)	1
	Back (in.)	1

Note: Before installing, consult installation instructions packed with product for current dimensional data.



Total volume and shelf area are calculated by the Association of Home Appliance Manufacturers' standards.



Listed by Underwriters Laboratories



HTS18JBN – Hotpoint 17.9 Cu. Ft. Top-Freezer Refrigerator

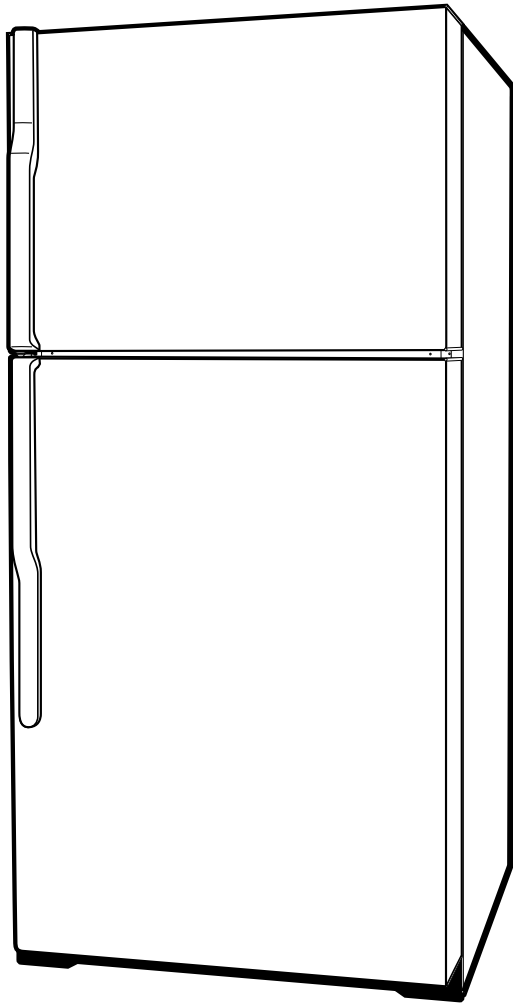

Features and Benefits

- 17.9 cu. ft. Capacity (Fresh Food 12.89 cu. ft./Freezer 5.03 cu. ft.)
- 2 Adjustable Full-Width Glass Fresh Food Cabinet Shelves
- Illuminated Upfront Temperature Controls
- 3 Fresh Food Door Shelves (2 Fixed – 1 with Gallon Storage; 1 Split with Gallon Storage)
- 2 Fruit/Vegetable Crispers
- Equipped for Optional Automatic Icemaker
- 1 Adjustable, Full-Width Wire Everwhite Freezer Compartment Shelf
- Model HTS18JBNCC – Bisque on bisque
- Model HTS18JBNWW – White on white