

HOTPOINT®

HTS16BBM – Hotpoint 15.6 Cu. Ft. Top-Freezer Refrigerator

Front View

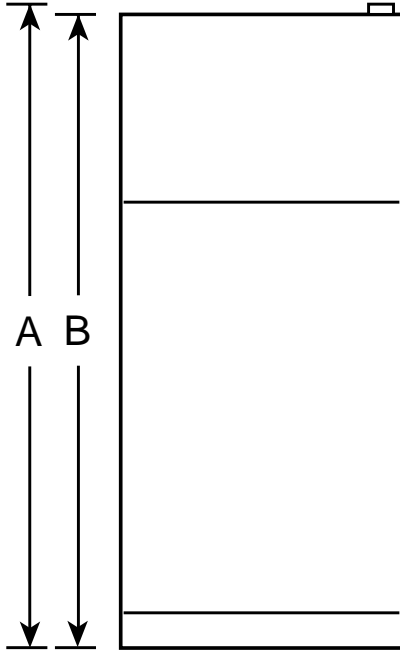

Top View

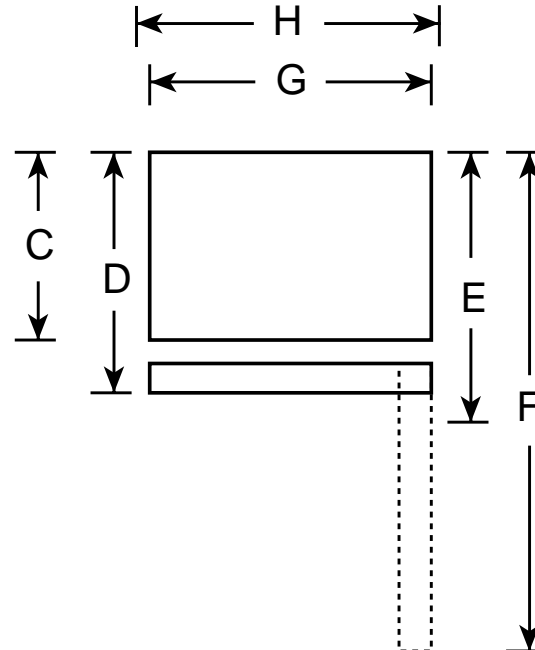

Overall Dimensions	Height with hinge (in.) A	64-3/4
	Height without hinge (in.) B	64-1/4
	Depth without doors (in.) C	25-7/8
	Depth with doors (in.) D	29-1/8
	Depth plus handle with doors closed (in.) E	31
	Depth with doors open 90° (in.) F	63
	Width with doors closed (in.) G	28
Air Clearances	Width with doors open 90° less door handle (in.) H	28-5/8
	Each side (in.)	3/4
	Top (in.)	1
	Back (in.)	1

Note: Before installing, consult installation instructions packed with product for current dimensional data.



HOTPOINT®

HTS16BBM – Hotpoint 15.6 Cu. Ft. Top-Freezer Refrigerator

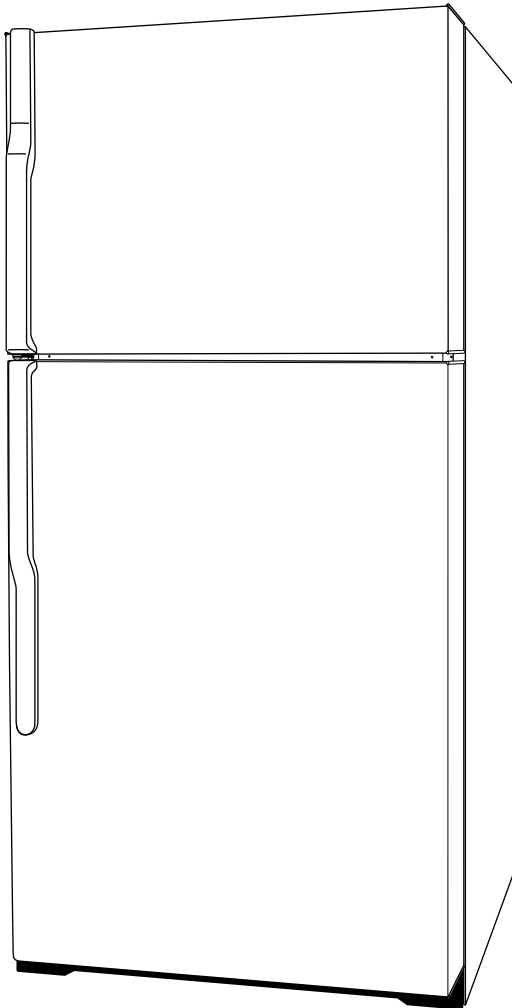

Features and Benefits

- 15.6 cu. ft. Capacity (Fresh Food 11.69 cu. ft./Freezer 3.86 cu. ft.)
- Equipped for Optional Automatic Icemaker
- 2 Vegetable/Fruit Crispers
- 2 Adjustable Full-Width Wire Everwhite Fresh Food Cabinet Shelves
- 2 Fresh Food Door Shelves with Tall Bottle Storage
- Dairy Compartment
- 2 Fixed Freezer Door Shelves
- 2 Ice 'N Easy Trays with Ice Tray Shelf
- Deluxe Quiet Design Quiet Package
- Color-Matched Door Handles
- Model HTS16BBMWW – White on white
- Model HTS16BBMCC – Bisque on bisque