

36" Island Vent

HCH6500ALS



Product image does not represent final photography.

Signature Features

580 CFM Motor

Helps with the removal of smoke, grease, and odors

LED Display

Provide the convenience of knowing the fan status at a glance

Five-Layer Washable Grease Filter

Draws out fumes and vapors, with easy detachment for safe, simple cleaning

Halogen Lighting

Distributes bright, clear light across the cooking surface

Available

Unit Specifications

Width	35 3/8"
Depth	23 5/8 "
Height	26 3/8" - 46 5/8"
Weight	68.36 lb.
UPC	688057374499

More Easy-To-Use Features

- Four Speeds
- 4 Halogen Lamps
- Aluminum Motor
- LED Display
- Electronic Controls
- Tempered Glass
- 304 Stainless Steel
- 120V, 60Hz

Warranty

- 2 Year Warranty (Parts and Labor)

Available Finishes



Stainless

Overall Packaging Details

Packaging	lb./in.	
Gross Weight	82.69 lb.	
Dimensions	W	37.25"
	D	18.72"
	H	25.35"

Power Requirements

Electrical Rating	120V, 60Hz
-------------------	------------

Product Technical Illustration

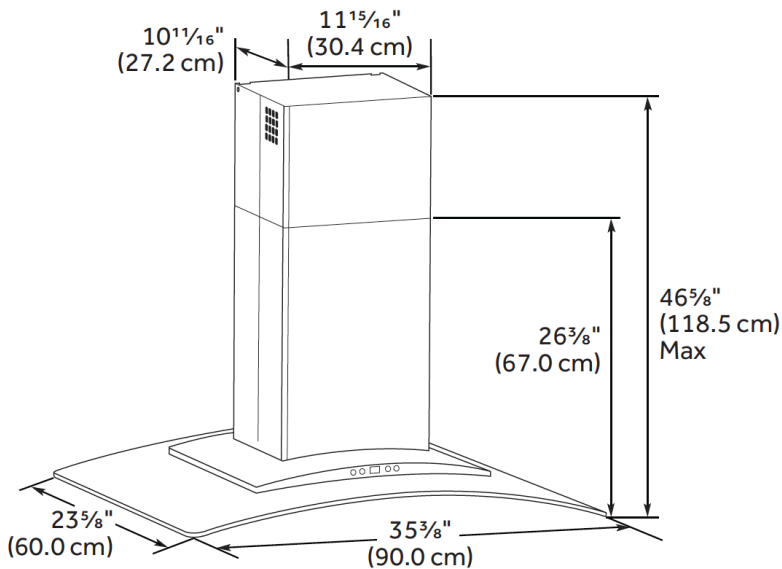

Note: The vent hood must be installed 24" min. above electric cooktop surface and 30" min. above gas cooktop surface.

The hood installation height, from the cooking surface to the bottom of the hood, depends upon ceiling height.

General Appliance Information

Please read all installation details and instructions before use.

Contact Us

For questions regarding this product please refer to our website at haieramerica.com or call our customer service center at 877-337-3639.

