

# HOTPOINT®

## RB800WJ/CJ/BJ– Hotpoint 30" Free-Standing Electric Range

### Dimensions (in inches)

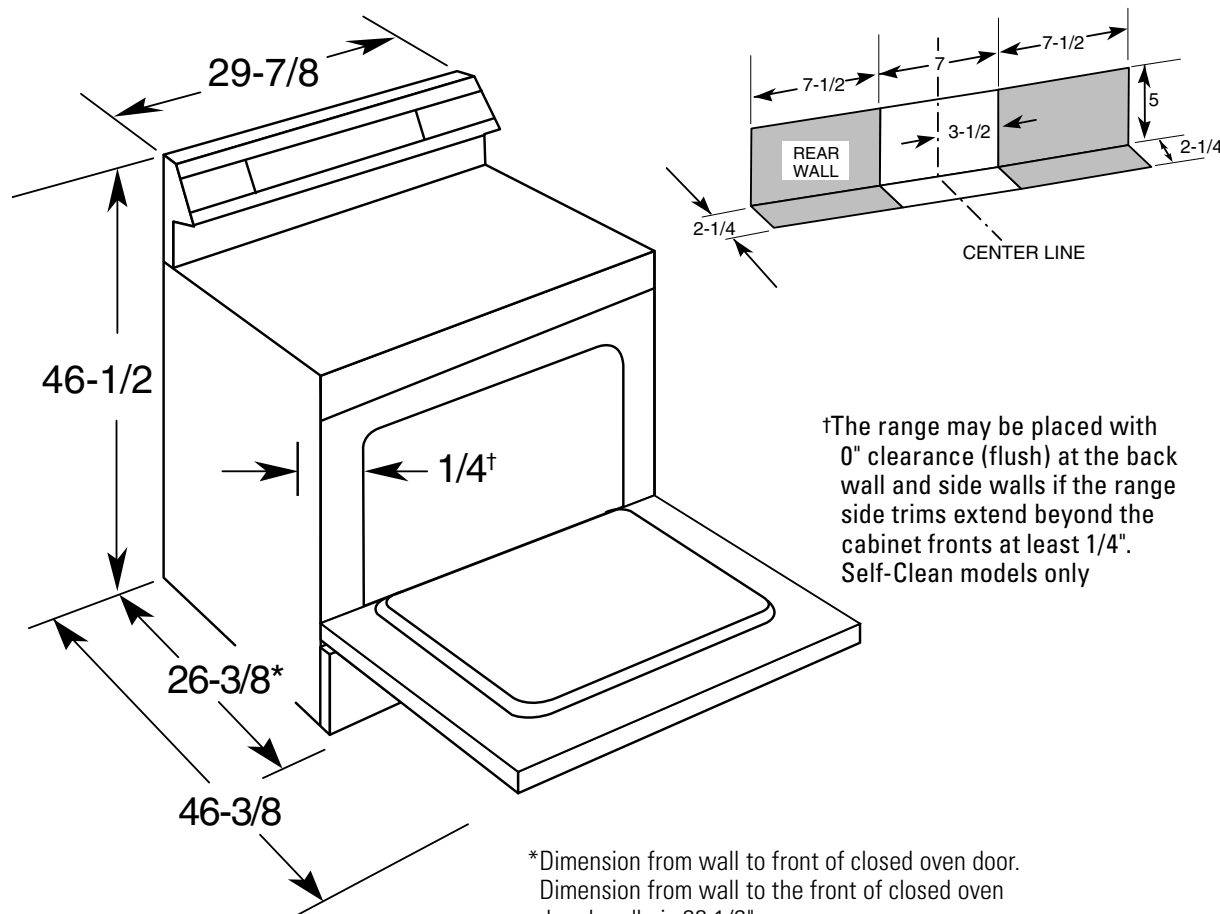

\*Dimension from wall to front of closed oven door.  
Dimension from wall to the front of closed oven door handle is 28-1/2".

Amp Rating	
240V	10.5
208V	7.9
Breaker Size	
40 Amps†	

†**Note:** Check local codes for required breaker size.

Effective January 1, 1996, the National Electrical Code requires that new construction (not existing) utilize a 4-conductor connection to an electric range.

**Note:** 30" Electric Ranges conform to U.L. requirements for 0" spacing from walls below countertops. Allow 1-1/2" spacing from the side of the range to adjacent vertical walls above the cooktop surface.

**Receptacle Locations:** Locally approved flexible service cord or conduit must be used because terminals are not accessible after range installation. See shaded area in drawing for location of electrical outlet box. Recommended outlet locations allow range to be installed directly against rear wall.

**Installation Information:** Before installing, consult installation instructions packed with product for current dimensional data.



All Hotpoint ranges are equipped with an Anti-Tip device. The installation of this device is an important, required step in the installation of the range.



Listed by Underwriters Laboratories

# HOTPOINT®

## RB800WJ/CJ/BJ– Hotpoint 30" Free-Standing Electric Range

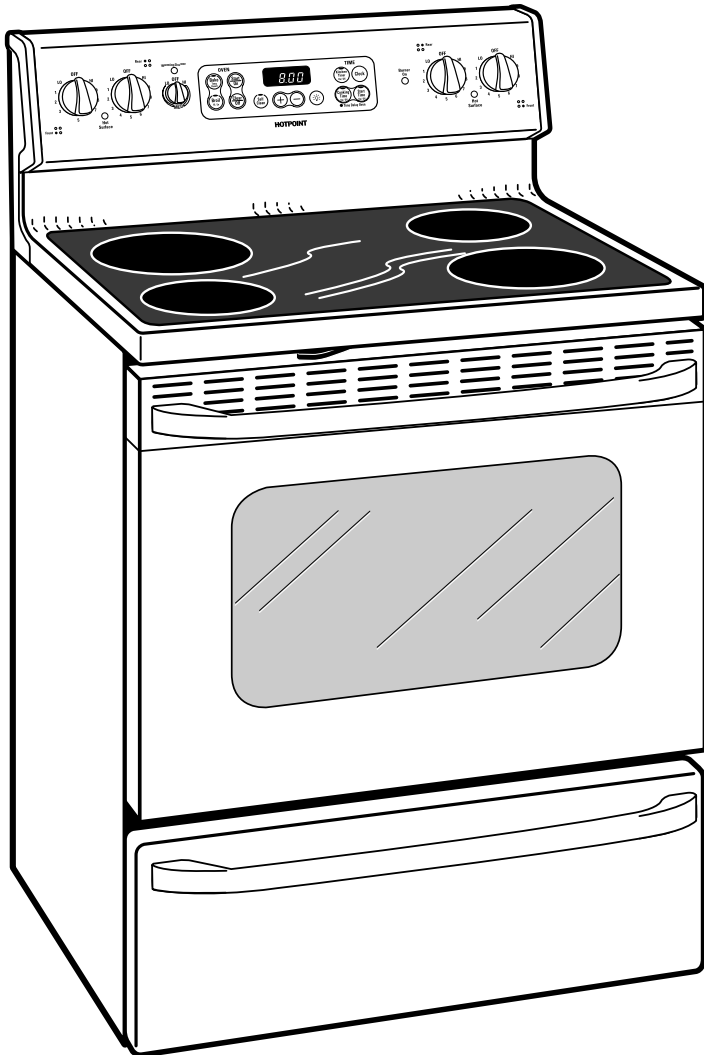

### Features and Benefits

- Self clean oven – Conveniently cleans the oven cavity without need of scrubbing
- Ceramic glass cooktop – A smooth cooktop surface makes cleaning quick and easy
- Ribbon heating elements – Provide powerful heat beneath a smooth glass surface to ensure even heat and fast warm-up times
- Super-large oven capacity – Provides an impressively large oven interior for cooking more dishes and large meals at one time
- Warming drawer – Convenient drawer keeps breads, desserts or just-cooked foods warm and ready-to-serve
- Electronic oven controls – One-touch electronic pads are easy-to-use and allow for simple oven operation
- Big View Window – Provides a large, convenient viewing area to check the progress of food
- Two oven racks – Features a durable construction to help accommodate any size or type of cookware
- Model RB800WJWW – White on white (white glass door and white patterned cooktop)
- Model RB800CJCC – Bisque on bisque (bisque glass door and bisque patterned cooktop)
- Model RB800BJBB – Black on black (black glass door and black patterned cooktop)

Specification Revised 11/05

420492