

HOTPOINT

HTS16HBM - Hotpoint 15.6 Cu. Ft. Top-Freezer Refrigerator

Front View

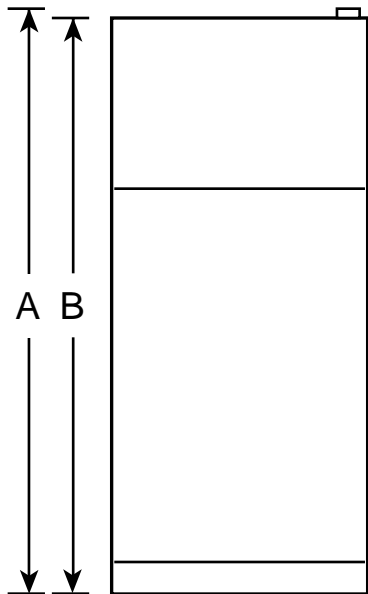

Top View

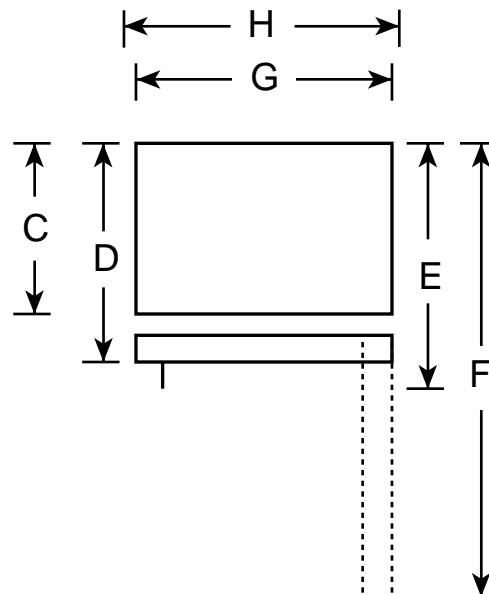

Overall Dimensions	Height with hinge (in.) A	64-3/4
	Height without hinge (in.) B	64-1/4
	Depth without Doors (in.) C	25-7/8
	Depth with Doors (in.) D	29-1/8
	Depth plus Handle with Doors Closed (in.) E	31
	Depth with Doors open 90° (in.) F	54-7/8
	Width with Doors Closed (in.) G	28
	Width with Doors open 90° Less Door Handles (in.) H	28-5/8
Air Clearances	Each side (in.)	3/4
	Top (in.)	1
	Back (in.)	1

Note: Before installing, consult installation instructions packed with product for current dimensional data.



Total volume and shelf area are calculated by the Association of Home Appliance Manufacturers' standards.



Listed by Underwriters Laboratories

HOTPOINT

HTS16HBM - Hotpoint 15.6 Cu. Ft. Top-Freezer Refrigerator

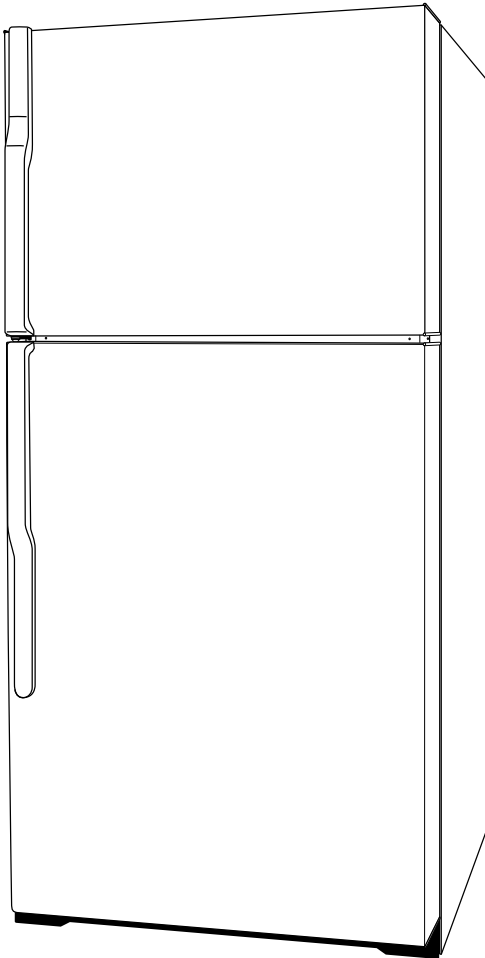

Features and Benefits

- 15.6 cu ft Capacity (Fresh Food 11.69 cu ft / Freezer 3.86 cu ft)
- Equipped for Optional Automatic Icemaker
- 2 Vegetable/Fruit Crispers
- Snack Pan
- 2 Split, 1 Full-Width (Adjustable) Glass Fresh Food Cabinet Shelves
- 2 Fixed Fresh Food Door Shelves with Gallon Storage
- Dairy Compartment
- Utility Bin
- Step Shelf
- 2 Fixed Freezer Door Shelves
- 2 Ice 'n Easy Trays
- Deluxe Quiet Design
- Color-Matched Door Handles
- Model HTS16HBMWW - White on white
- Model HTS16HBMAA - Almond on almond