

GE Apartment Appliance Guide



Featuring GE® and Hotpoint® appliances



We bring good things to life.

GE gives you the industry's best service

Professional Sales Support and Authorized Distributors

Knowledgeable and responsive inside and outside sales teams know your market and understand your needs, giving unmatched support in the industry. For customers who want local support and showrooms, GE authorized distributors are an excellent resource. They serve the property management industry and offer custom services to fit almost any special need.



Get connected to GE support with GE CustomerNet

GECustomerNet.com

GECustomerNet.com is more efficient and easier than ever. Our online network gives you fast, reliable access to GE products and services 24/7. It's a complete online ordering and marketing system that interfaces with GE to serve you better.

- *Appliance Orders*

GE CustomerNet allows you to order appliances quickly and efficiently. Orders can be placed any time.

- *Parts Orders*

GE CustomerNet puts ordering parts and scheduling service calls at the tip of your fingers. It also enables you to check availability and track your order status.

- *Productivity Solution*

ICR—No computer system? Use our ICR (intelligent character recognition) program for faxing efficiency in placing orders.

IVR—Check price availability, order status and conduct business any time with the immediate response of IVR (intelligent voice recognition).

GE Answer Center®

800.626.2000

A free call to the GE Answer Center can answer all your questions about any GE® and Hotpoint® appliances. Everything from product specifications and installation, to feature and benefit information, and more. Call any time. We never close!

GE Appliances Online

BuildwithGE.com

Get immediate access to installation instructions, manuals and information on all GE products, parts, service contracts and more at our easy-to-use Web site—24 hours a day!

GE Power Buyer Service

powerbuyerservice.com

800.432.2847

Access many national vendors who provide exclusive services to the property management industry. Benefits include money back performance guarantees, free inspections/surveys, extended warranties and more. National vendors include York International—HVAC, GE Silicons—roofing, ICI Dulux Paint Centers—paints, Shaw—carpentry, American Water—water management plus many more.



and support right at hand.

Availability and delivery you can count on.

Get the appliances you want, whenever and wherever you want with our efficient computerized Availability Management System. We'll ship directly to our customers and distributors or to a network of more than 100 scheduled delivery service locations which will provide local delivery to you.

GE Genuine Parts

800.851.6200

Depend on GE for quality parts and accessories. See the back of this publication for details on our complete parts program.

GE makes servicing appliances our job—not yours.

800.GE.CARES

If you need repairs, you'll get a quick response from the largest manufacturer-owned and -authorized service organization in the appliance industry. And now you can schedule repair service online (GEAppliances.com)—more than one thousand highly trained technicians are just one click away!

GE Commercial Property Program

800.626.8690

If you manage properties, a maintenance problem in one or two of your units is critical! With our Commercial Service Program, GE's expert service is available to help at your convenience.

- Flat rate commercial pricing
- Authorized wholesale parts pricing
- Factory-trained GE service technicians
- General Electric quality and reputation
- A personal representative for your service requests
- Only local estimate fee charged on unreparable units

Maintenance and repair training

Learn how to maintain and repair your on-site GE appliances. Call your GE Area Sales Manager to find out about potential maintenance training opportunities in your area.

- Use and care
- Maintenance
- Minor repair work
- Troubleshooting
- Teardown and reassembly



Designed specifically for your properties,



#1 Start with the highest quality refrigerator in America!*

We're so confident about the quality of our refrigerators that we surveyed the toughest customers. Several hundred maintenance managers randomly selected from a national list of property management firms were asked to rate 13 to 17 cu. ft. refrigerators for quality. GE® was mentioned as the brand with the highest quality by more than a two-to-one margin over every other brand.

GE refrigerators satisfy the most demanding customers.

Maintenance managers prefer GE refrigerators because these quality appliances make their jobs easier. They can count on GE refrigerators for reliable, long-lasting performance.

Inside and out, GE refrigerators are built to last.

- The galvanized finish stands up to the most humid environments, providing protection from rust.
- Recessed pocket handles and encased NeverClean™ condenser offer convenience and allow the refrigerator to fit through most passageways.
- The heavy-duty center hinge system is factory-set for proper door alignment and helps support heavier door loads.
- The fresh food door cross-bracing provides extra support and eliminates door sagging under heavy loads.
- Evaporator elements ensure quiet operation.
- Convenient features make them easy to maintain.
- An easy-to-set temperature control ensures temperature stability in the fresh food and freezer compartments.

All top-freezer models are built to comply with 2001 energy-use guidelines and 2003 clean air requirements.

*Results (among 13 to 17 cu. ft. models) based on a 1999 survey of property management maintenance personnel.

GE appliances are attractively styled and easy to coordinate. GE has earned a reputation for quality by consistently providing products and services that satisfy consumers. Choose GE and offer your customers the features they want.

GE appliances are the perfect choice.

Maintenance managers aren't the only people who give GE rave reviews. Builders, remodelers and property managers like you rate GE #1 in overall customer satisfaction. And tenants prefer GE, too. According to the 2000 Louis Harris poll, GE is the appliance brand most often mentioned among the brands rated as offering the best products and services in America. And while our refrigerators serve as excellent examples of GE quality, we offer a full line of appliances with a host of exclusive, apartment-friendly features.

The GE Nautilus™ dishwasher quietly delivers superclean dishes.

In most apartments, the kitchen is in close proximity to the family room, so quiet operation is a must. The new GE Nautilus dishwasher meets this demand. This innovative dishwasher operates with the exclusive:

- GE QuietPower™ motor—GE's quietest motor ever.
- QuietPower I sound package—"All you'll notice is the clean."™
- HotStart™ option delivers hot water for cleaner dishes.



GE ranges satisfy the demands of the heartiest appetites!

The GE oven is designed with a full 5.0 cubic feet. That means users no longer have to take an a la carte approach to cooking—the oven's capacity is spacious enough to handle a large quantity of food.

- GE's exclusive six-rack capability accommodates a variety of cookware.



The Spacemaker® laundry pair makes the most of a tight situation.

The GE stackable washer and dryer pair has a unique configuration that eases its way into any situation. And wherever it is—out of the way or out of sight—this stackable laundry pair works wonders with:

- GE's sturdy Stack Rack provides more space between the washer and dryer.
- A built-in fluorescent light shines down from the Stack Rack to illuminate the wash tub.
- The enlarged 2.7 cu. ft. capacity can handle almost any load.
- Digital controls allow programming convenience with loading-sensing capabilities.



These new appliances are just some of the ways you can make life easier for yourself and your tenants (and let's not forget your maintenance managers). To learn more, call the GE Answer Center® day or night at 1.800.626.2000. Or visit our Web site: GEpropertymanagement.com.

GE® Refrigerators: Side-By-Side Model



Deluxe Quiet Design—quiet components and insulation allow for quiet operation.



GSS20DBM

- 19.8 cu. ft. capacity • Upfront electronic temperature controls
- FrostGuard™ technology • Deluxe quiet design • Equipped for optional electronic automatic icemaker • One sealed crisper • One sealed deli pan
- Four fresh food door bins, two with gallon storage • Four wire freezer shelves, three adjustable • NeverClean™ condenser

GE Refrigerators: Top-Freezer No-Frost Models



Deluxe Quiet Design—quiet components and insulation allow for quiet operation.



Fresh food door cross-bracing provides extra support, eliminates door sagging under heavy loads.



NeverClean condenser coils are rolled up and encased, so they never require cleaning in normal operating environments.



GTS18EBM

- 17.6 cu. ft. capacity • Three cabinet shelves, one full-width wire, one split wire and one split glass • Two classic white vegetable/fruit crispers • Snack pan • Two door shelves with tall bottle storage • Deluxe quiet design • Equipped for optional electronic icemaker
- NeverClean condenser

Not all features available on all models.

For additional features, specifications and color availability, refer to pages 33 and 34.

GE Refrigerators: Top-Freezer No-Frost Models



GTS18DCM

- 17.9 cu. ft. capacity • Upfront illuminated temperature controls • Three wire shelves, two adjustable split and one full-width
- Two classic white vegetable/fruit crispers
- Snack pan • Three door shelves, two with gallon storage • Deluxe quiet design
- Upfront fresh food lighting • Spill-proof freezer floor • Color-matched handles
- Equipped with factory-installed electronic icemaker • NeverClean condenser

GTS18DBM (not shown)

- Similar features and appearance as GTS18DCM, but equipped for optional electronic icemaker

GTH18DBM (not shown)

- Similar features and appearance as GTS18DCM, except equipped for optional electronic icemaker



As an ENERGY STAR® partner, GE has determined that this product meets the ENERGY STAR® guidelines for energy efficiency.

(Model GTH18DBM)



GTR18BBM

- 17.6 cu. ft. capacity • Recessed handles
- Two fixed freezer door shelves • Upfront temperature controls • Two adjustable wire full-width shelves • Deluxe quiet design
- Equipped for optional electronic icemaker • NeverClean condenser

GTS17BBM (not shown)

- 16.9 cu. ft. capacity • Color-matched handles • Equipped for optional electronic icemaker

GTR17BBM (not shown)

- 16.9 cu. ft. capacity • Recessed handles
- Equipped for optional electronic icemaker

GTS15BBM (not shown)

- 14.6 cu. ft. capacity • Color-matched handles • Equipped for optional electronic icemaker

GTH15BBM (not shown)

- 14.6 cu. ft. capacity • Color-matched handles • Equipped for optional electronic icemaker

GTR15BBM (not shown)

- 14.6 cu. ft. capacity • Recessed handles
- Equipped for optional electronic icemaker



As an ENERGY STAR® partner, GE has determined that this product meets the ENERGY STAR® guidelines for energy efficiency.

(Model GTH15BBM)

GTS12BBM (not shown)

- 11.7 cu. ft. capacity • One full-width, white divided crisper • Two and one-half fixed door shelves • Equipped for optional electronic icemaker

GTS17BCM (not shown)

- 16.9 cu. ft. capacity • Two classic white vegetable/fruit crispers • Two fixed door shelves with tall bottle storage • Two fixed freezer door shelves • Color-matched handles • Equipped with factory-installed electronic icemaker • NeverClean condenser

GTS16BBM (not shown)

- 15.6 cu. ft. capacity • Two fixed door shelves with tall bottle storage • Color-matched handles • Deluxe quiet design

GTS15BCM (not shown)

- 14.6 cu. ft. capacity • Color-matched handles • NeverClean condenser

GTS10AAM (not shown)

- 10.3 cu. ft. capacity • One wire full-width freezer shelf • Two wire full-width shelves
- One full-width white vegetable/fruit crisper • Color-matched handles • Deluxe quiet design

Not all features available on all models.

For additional features, specifications and color availability, refer to page 33.

GE® Refrigerators: Cycle and Manual Defrost Models



GFR12AAM

- 11.7 cu. ft. capacity
- Three door shelves • Two clear vegetable/fruit crispers



GMS10AAM

- 9.7 cu. ft. capacity • Full-width vegetable/fruit crisper • Tall bottle storage
- Two adjustable wire cabinet shelves

GE Refrigerators: GE Spacemaker™ Compact Models



GMR06AAM

- 6.0 cu. ft. capacity • Two adjustable cabinet shelves • Three full-width door shelves • Interior light • Optional black panel and door handle available with TK6 trim kit

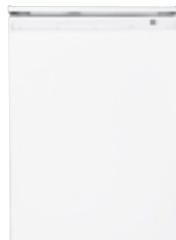

GMR04BAN (not shown)

- 4.3 cu. ft. capacity • Two and one-half wire cabinet shelves • One full-width, two half-width door shelves • Can rack

GMR02BAN

- 1.7 cu. ft. capacity • One slide-out wire cabinet shelf
- One full-width, one half-width door shelf

Not all features available on all models.

For additional features, specifications and color availability, refer to page 34.

GE Profile Advantium™ 120 Speedcook Oven



The flexible, above-the-cooktop configuration makes the most of your kitchen space and installs with ease. Just mount it over a counter, range or cooktop and plug it into any standard 120-volt power outlet.



SCA100DWW White on white

- Four cooking modes: Speedcook, traditional oven, microwave and warming
- More than 100 preprogrammed menu items
- Complete cooking reminder
- Child lockout
- Full-view halogen cooktop lighting

SCA100DBB

Black on black (not shown)

SCA100DCC

Bisque on bisque (not shown)

Compact Built-In Cooktops



JP201CB Stainless steel

- One 8" and one 6" plug-in heating element
- Infinite heat rotary controls
- Removable one-piece chrome drip bowls
- Heating element "ON" indicator light

JP202D White on white (not shown)

Not all features available on all models.

For additional features, specifications and color availability, refer to page 35.

GE® Free-Standing Electric Ranges: 30" QuickClean™ Self-Clean Models



Lift-up cooktop locks into place for easy cleaning.



Clean-Well™ cooktop system on most free-standing ranges is designed with a combination of features for total cleaning simplicity. Includes upswept cooktop, spill containment system, seamless subtop with spill wells, one-piece drip bowls and lift-up cooktop on some models.



JBP26WB

- Self-cleaning • TrueTemp™ system
- Super-large 5.0 cu. ft. capacity oven
- SmartLogic™ electronic controls
- Six-pass power bake element • Standard window • QuickSet III controls



JBP24BB

- Self-cleaning • Super-large 5.0 cu. ft. capacity oven • Auto self-clean
- Clean-Well cooktop system
- Lift-up cooktop • Standard window
- QuickSet II oven controls • Available in white or bisque

JBP24WB (not shown)

- White on White



Calrod® heating elements provide even heat distribution for better cooking performance.



JBP21WC

- Self-cleaning • Auto self-clean • Clean-Well cooktop system • Lift-up cooktop • QuickSet II oven controls • Frameless solid white glass oven door • Designer-style handle



JBP21BC

- Self-cleaning • Auto self-clean • Clean-Well cooktop system • Lift-up cooktop • QuickSet II oven controls • Frameless solid black glass oven door • Designer-style handle



QuickSet oven controls provide an easy, two-step self-cleaning oven operation. Simply latch the oven door and turn oven knob to "Auto Self-Clean."

Not all features available on all models.

For additional features, specifications and color availability, refer to page 36.

GE Free-Standing Electric Ranges: 30" QuickClean Standard-Clean Models



JBS27BC

- Super-large 5.0 cu. ft. capacity oven
- Standard clean oven • Lift-up cooktop
- Plug-in Calrod heating elements, two 8" and two 6" • Electronic clock and minute timer
- Heating element "ON" indicator light • Frameless black glass oven door with window • Designer-style handle
- Removable full-width storage drawer



JBS26C

- Super-large 5.0 cu. ft. capacity oven
- Standard clean oven • Clean-Well cooktop system • Electronic clock and minute timer
- Plug-in Calrod heating elements, two 8" and two 6" • Removable one-piece chrome drip bowls • Heating element "ON" indicator light • Color-matched oven door with window
- Designer-style handle • Removable full-width storage drawer



JBS07C

- Super-large 5.0 cu. ft. capacity oven
- White on white • Standard clean oven
- Plug-in Calrod heating elements, one 8" and three 6" • Oven door with window • Designer-style handle
- Interior oven light switch

30" Front Control Model



JBS03BC

- Super-large 5.0 cu. ft. capacity oven
- Standard clean oven • Plug-in Calrod heating elements, one 8" and three 6" • Frameless solid black glass oven door • Designer-style handle
- Removable full-width storage drawer



JBS03C

- Similar features and appearance as JBS03BC, except has solid color-matched oven door and chrome visor handle.



JBS05Y

- Standard clean oven • Upfront controls
- Plug-in heating elements, one 8" and three 6" • Removable one-piece chrome drip bowls • Two oven shelves
- Color-matched oven door with window
- Chrome visor handle • Storage drawer

Not all features available on all models.

Note: Range cord kit sold separately.

For additional features, specifications and color availability, refer to page 36.

GE® Electric Ranges: 30" Slide-In Models



JSP26BD

- Lift-up overhanging porcelain-enameled cooktop
- Two 8" and two 6" plug-in Calrod® heating elements
- Electronic clock and kitchen timer • SmartSet electronic controls • Self-cleaning oven with Delay Clean option • Frameless glass oven door with designer-style handle • Control lock capability
- Available in white or bisque

JSS16PD (not shown)

- Standard clean oven • Color-matched oven door
- Visor handle • Available in white or bisque

GE Electric Range: 27" Drop-In Model



JMS08BD

- Standard clean oven • White or bisque cooktop
- Rotary oven controls • Lift-up overhanging porcelain-enameled cooktop • One 8" and three 6" plug-in Calrod heating elements • Frameless glass oven door • Big View window • Chrome drip bowls
- Available in white or bisque

GE 30" Standard Hoods



JV327X

- Vented • 30" width • 7" round duct • Easy-to-use rocker switches • Two-speed fan • Cooktop light
- Available in white, bisque or almond

JXDA22 round damper accessory available at additional cost.



JN327X

- Non-vented • 30" width • Easy-to-use rocker switches • Two-speed fan • Cooktop light
- Available in white, bisque or almond

Not all features available on all models.

For additional features, specifications and color availability, refer to pages 36 and 37.

GE Gas Ranges: 30" XL44™ Free-Standing Models



One-piece upswept cooktop raised edge helps contain spills; has no cracks or crevices to trap dirt or food particles.



Extra-large XL44 oven capacity is large enough to prepare an entire holiday dinner at once.



JGBP24BEA

- Extra-large self-cleaning oven • Standard burners • Square, standard porcelain-steel, grates • Lift-up cooktop • QuickSet II oven controls • Frameless black glass oven door with designer-style handle • Certified Sabbath mode



JGBS20BEA

- Extra-large standard clean oven • Standard burners • Square, standard porcelain-steel grates • Lift-up cooktop • Electronic clock and minute timer • Frameless black glass oven door with designer-style handle • Slide-out broiler drawer

JGBS17PEA (not shown)

- Similar features and appearance as JGBS20BEA, except has color-matched porcelain-enameled oven door with window.



JGBS04PEA

- Extra-large standard clean oven • Standard burners • Black standard porcelain-steel grates • Solid porcelain-enameled oven door with chrome visor handle • Electronic pilotless ignition

JGBS04PPA (not shown)

- Similar features and appearance as JGBS04PEA, except has standing pilot ignition.



JGBS04BEA

- Extra-large standard clean oven • Frameless solid black glass oven door with designer-style handle • Electronic pilotless ignition

JGBS04BPA (not shown)

- Similar features and appearance as JGBS04BEA, except has standing pilot ignition.



JGBS03PPA

- Solid porcelain-enameled oven door with chrome visor handle • Standing pilot ignition • Drop-down broiler drawer

Not all features available on all models.

Note: Range cord kit sold separately.

For additional features, specifications and color availability, refer to page 37.

GE Spacemaker® Over-the-Range Microwave Ovens



This powerful 300-CFM venting system quickly removes smoke and steam from your cooktop.



Convenience cooking controls allow you to defrost, cook or reheat at the touch of a pad.

Recirculating Charcoal Filter Kit available at additional cost. Order JX81, JX81A or JX81B.



JVM1630BB Black on black
 • 1.6 cu. ft. oven cavity • 1000 watts* • CircuWave™ cooking system
 • Convenience cooking controls • Turntable • Auto/Time Defrost
 • Express Cook • Add 30 seconds



JVM1631BB Black on black (not shown)
 • Non-vented model
JVM1630WB White on white (not shown)
JVM1631WB White on white (not shown)
 • Non-vented model
JVM1631CD Bisque on bisque (not shown)
 • Non-vented model



JVM1441WD White on white
 • 1.4 cu. ft. oven cavity • 950 watts* • CircuWave cooking system
 • Turntable On/Off • Removable rack • Non-vented model



JVM1441BD Black on black (not shown)
 • Non-vented model

GE Spacemaker II™ Microwave Oven



Undercabinet Mounting Kit allows you to install a countertop microwave oven under your cabinetry, freeing up valuable counter space.

Not all features available on all models.

For additional features, specifications and color availability, refer to page 38.



JEM25WY White on white
 • Mid-size .9 cu. ft. oven cavity • 800 watts* • Convenience cooking controls
 • Auto/Time Defrost • Sound on/off • Optional trim kit available**
 • Optional undercabinet mounting kit available†



JEM25GY Black with greystone case (not shown)

*IEC-705 Test Procedure

**Optional trim kit—Custom trim kits available in both 27" and 30" configurations at additional cost.

†Undercabinet mounting kit—Noted microwave ovens can easily be mounted below your cabinetry, freeing up valuable counter space. A mounting template provides all the necessary measurements for installation on practically any wood or metal cabinets.

GE® Microwave Oven with Convenience Cooking



JE740GY
Black with greystone case
(not shown)

- JE740WY** White on white
- Compact .7 cu. ft. cavity • 700 watts* • Electronic digital display with clock
 - Optional undercabinet mounting kit available†

GE Compact Microwave Oven



JE520WC
White on white
(not shown)

- JE520BW** Black on black
- .5 cu. ft. cavity • 600 watts* • Electronic touch controls • Electronic digital display with clock • Turntable • Time Defrost • Optional undercabinet mounting kit available†

*IEC-705 Test Procedure

†Undercabinet mounting kit—Noted microwave ovens can easily be mounted below your cabinetry, freeing up valuable counter space. A mounting template provides all the necessary measurements for installation on practically any wood or metal cabinets. Pub. No. 4-A019 is available at an additional cost.

Not all features available on all models.

For additional features, specifications and color availability, refer to page 38.

GE® Clothes Care: Washer and Dryer Models



Auto Balance Suspension System is designed to virtually eliminate off-balanced loads. This system is designed to operate on wood floors as well as concrete.



PermaTuf II™ Basket resists peeling, chipping, rusting or flaking for long-term durability.

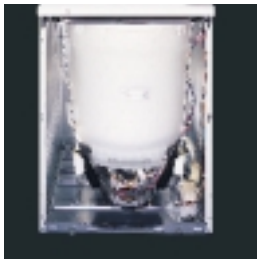

100% front serviceable for easy access to operational parts without moving the unit.



Reverse-A-Door is the ultimate in flexibility. Change door swing to accommodate your laundry area.



WCSE4160B Washer

- 3.2 cu. ft. super capacity plus • 4 wash/spin speed combinations • 16 wash cycles • 3 water levels • 3 wash/rinse temperatures • Power Rinse • Fabric softener dispenser • Bleach dispenser • Quiet-By-Design™ • 100% front serviceable

WSCR2080B Washer (not shown)

- 3.2 cu. ft. super capacity • 2 wash/spin speed combinations • 8 wash cycles • 3 water levels • 3 wash/rinse temperatures



DBL333EB Electric Dryer

DBL333GB Gas Dryer

- 5.7 cu. ft. extra-large capacity • Automatic Dry Control • 3 drying cycles • 3 heat selections • Reverse-A-Door • Upfront lint filter • 100% front serviceable

DBXR463EB Electric Dryer (not shown)

DBXR463GB Gas Dryer (not shown)

- 6.0 cu. ft. extra-large capacity • Automatic Dry Control • 6 drying cycles • 4 heat selections • Reverse-A-Door • Quiet-By-Design • 100% front serviceable

GE Clothes Care: Front-Loading Models



WSXH208A*

- ENERGY STAR model • 2.7 cu. ft./3.1 IEC extra-large capacity • High-efficiency washer • 8 wash cycles • 4 wash/rinse temperatures • Automatic water level adjustment • Extra-Rinse Cycle/Auto Option, 3 standard rinse cycles • Fabric softener dispenser • Bleach dispenser • Available in White on white

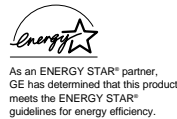

DSXH43EA/GA 240V*

- 5.7 cu. ft. extra-large capacity • Tumble drying • Timed Dry cycle • 2 Auto Dry cycles (Cottons, Easy Care) • 4 temperature options • End-of-cycle signal • Dryer interior light • Reverse-A-Door • Dryer rack • Available in White on white

*Units can be stacked or built in. Undercounter kits required for undercounter use.

Not all features available on all models.

For additional features, specifications and color availability, refer to pages 39 and 41.

GE Clothes Care: Spacemaker® Portable/Stationary Models

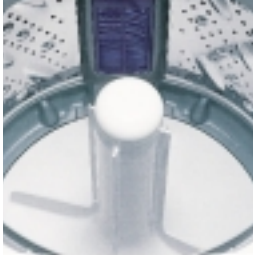

Extra-large 2.7 cu. ft. stainless steel tub with lint filter.

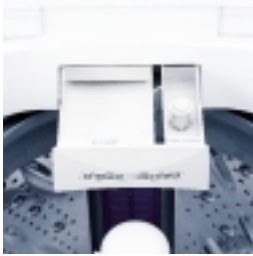

Easily accessible detergent/fabric softener dispenser.



DSLR24AW shown with WSLP1100A Washer and DSKS433EB Dryer



WSLP1100A 120V
Portable/Topload Washer
 • 24", 2.7 cu. ft. extra-large capacity • 1 wash/spin speed
 • 10 cycles • 4 wash/rinse temperatures • 4 water levels
 • Load sensing • Electronic controls • Digital countdown
 • Bifold lid • Bleach dispenser
 • Fabric softener dispenser
 • Lint filters • Easy-roll rollers
 • Unicouple connector quickly attaches to a faucet adaptor
 • Available in White on white or white with black controls

WSLS1100A 120V
Stationary/Topload Washer (not shown)
 • Available in White on white



DSKS433EB 240V
240V Stationary Dryer
 • 3 drying cycles
 • 4 heat selections
 • Available in White on white



WSKP2060W 120V
Portable Washer
 • 2 wash/spin speeds • 6 cycles
 • 3 wash/rinse temperatures
 • 4 water levels • Unicouple connector quickly attaches to a faucet adaptor
 • Available in white with granite-look top

WSKS2060W 120V
Stationary Washer (not shown)
 • Available in white with granite-look top



DSKP233EW 120V
Portable/Stationary Dryer
 • 3 drying cycles
 • 2 heat selections
 • 15-amp dryer cord attached
 • Available in white with black control panel

DSLR24AW Stack Rack with Light (available at additional cost)
 • For use with Portable or Stationary Washers and Dryers

GE Clothes Care: Unitized Washer/Dryer Models



WSM2700W Electric
WSM2780W Gas
 • Full size 27" wide • Extra-large capacity Washer features 3 cycles (Regular, Permanent Press and Delicate), 3 wash temperature options, 3 water level selections
 • Dryer features Automatic Dry Control, 4 cycles: Automatic Regular Dry (Medium Heat), Timed Dry (High Heat), Delicate (Low Heat), Air Fluff (No Heat)
 • Available in White on white (electric model also available in Bisque on bisque)



WSM2420T Electric
WSM2480T Gas
 • 24" wide • Washer features 3 cycles (Regular, Permanent Press and Delicates), 3 wash/rinse temperatures, 3 water levels
 • Dryer features Automatic Dry Control, 4 cycles: Automatic Regular, Automatic Permanent Press, Timed Dry, and Air Fluff
 • Available in White on white (electric model also available in Bisque on bisque)

Unitized models ideal for closet installations, unitized washer/dryer combinations fit in space as small as 24" wide.

For additional features, specifications, color availability and special dryer installation requirements and exhausting information, refer to pages 40 and 41.

Not all features available on all models.

GE® Commercial Washers and Dryers



Washer is 100% front serviceable with all operational parts. Dryer is serviceable without moving the unit.



Unique upswept design provides a contemporary look and makes cleaning easy.



The GentlePower™ agitator adapts to the clothes load, providing gentle and effective washing action.



ArmorGuard protection provides a rust-resistant, durable finish to the washer top and lid.



WCCD2050B Two-Speed Washer

- Cycle countback • 2.7 cu. ft. extra-large capacity
- 5 wash cycles • 3 water levels (adjustable)
- 18.5 minute wash cycle • 2 wash/spin speed combinations • 3 wash/rinse temperatures
- Self-cleaning filter • 100% front serviceable

WCCB1030B Single-Speed Washer (not shown)

- 3 wash cycles • 1 wash/spin speed combination



DCD330EB/GB

- 5.7 cu. ft. extra-large capacity • Cycle countdown
- 3 cycles • 3 heat selections • Upfront lint filter
- 100% front serviceable • Reverse-A-Door

DCB330EB/GB (not shown)

- Automatic Dry Control • 3 cycles • 3 heat selections • Upfront lint filter • 100% front serviceable • Reverse-A-Door



WNCD2050A

- 3.2 cu. ft. super capacity plus • GE's Exclusive Auto Balance Suspension System • 4 water levels • 3 wash/spin speed combinations • 3 wash/rinse temperatures
- 5 wash cycles • Spin only • Digital cycle countdown • LED indicators for fill, wash, rinse and final spin • Bleach dispenser
- Fabric softener dispenser • Deluxe Quiet Plus

DNCD450EA/GA (not shown)

- 7.0 cu. ft. super capacity • 5 dry cycles
- 4 temperatures • Air dry • Cycle countdown
- Hush Quiet package • LED indicators for door open, drying, cool down, clean lint filter
- Lockable lint filters • Reverse-A-Door • Dryer interior light

Modular Commercial Dryers



DDC4400S Electric Dryer

DDC4500S Gas Dryer

- 5.4 cu. ft. extra-large capacity • Stacked pair
- 3 cycles • 3 heat selections
- "ON" indicator light
- 100% front serviceable
- Shipped preassembled
- Available in White only

Not all features available on all models.

For additional features, specifications and color availability, refer to pages 42 and 43.

Commercial Coin Front-Loading Washer and Dryer



Automatic water fill eliminates guesswork and water waste. Automatically adjusts to the load type by adding water. Water fill level remains below the door.



GE Commercial Coin Front-Loading Washer **WCCH404V** White

- 2.7 cu. ft. extra-large capacity • ENERGY STAR® • 3/wash, 1/rinse temperatures • Automatic water level adjustment • 4 wash cycles (Color Cottons, Permanent Press, White Cottons, Delicates)
- Stainless steel wash drum • Detergent dispenser • Fabric softener dispenser • Bleach dispenser

Commercial Coin Front-Loading Matching Dryer **DCCH43EA/GA** (not shown)

- 5.7 cu. ft. extra-large capacity • 4 dry cycles • 3 heat selections



As an ENERGY STAR® partner, GE has determined that this product meets the ENERGY STAR® guidelines for energy efficiency.

Commercial Smart Card Washers and Dryers

Increase income with pricing flexibility, upfront revenues, property image and more usage due to convenient payment. Lower operating costs with reduced collection costs, reduced vandalism and audit ability.



BridgePoint Smart Laundry™ card reader.



GE Commercial BridgePoint Smart Card Washer **WNCJ2050A** White

- 2.7 cu. ft. extra-large capacity • 3 wash/spin speed combinations
- 3 wash/rinse temperatures • 2-speed motor • 5 wash cycles • 4 water levels • Digital countdown cycle • Color Cottons • Bright Colors
- Permanent Press • White Cottons • Delicates • Bleach dispenser • Quiet Package • Lid instructions • LED indicators • BridgePoint Smart Laundry reader • Alphanumeric display • Control card

GE Commercial ESD Smart Card Washer **WNCK2050A** White (not shown)

- 2.7 cu. ft. extra-large capacity • 3 wash/spin speed combinations
- 3 wash/rinse temperatures • 2-speed motor • 5 wash cycles • 4 water levels (adj.) • Digital countdown cycle • Color Cottons • Bright Colors
- Permanent Press • White Cottons • Delicates • Bleach dispenser • Quiet Package • Lid instructions • LED indicators • ESD Smart Card reader
- Alphanumeric display • Control card



An extra-wide opening provides easy access to our 7.0 cu. ft. of total dryer capacity.



GE Commercial BridgePoint Smart Card Dryer **DNCJ440EA/GA** White

- 7.0 cu. ft. super capacity • 4 dry cycles • 4 heat selections
- Digital cycle countdown • Quiet Package • Lockable lint filter
- Reverse-A-Door • LED indicators • BridgePoint Smart Laundry reader • Alphanumeric display • Control card

GE Commercial ESD Smart Card Dryer **DNCK440EA/GA** White (not shown)

- 7.0 cu. ft. super capacity • 4 dry cycles • 4 heat selections
- Digital cycle countdown • Quiet Package • Lockable lint filter
- Reverse-A-Door • LED indicators • ESD Smart Card reader
- Alphanumeric display • Control card

Not all features available on all models.

For additional features, specifications and color availability, refer to page 43.

GE Nautilus™ Built-In Dishwashers



QuietPower™ motor is quieter and more energy efficient.



GSD3200GBB Black on black

- 5 cycles/22 options • PowerScrub™ wash system • Piranha™ hard food disposer
- Pots & Pans cycle • Plate Warmer cycle • Hi-Temp Wash option • HotStart option • Deluxe upper rack • Deluxe lower rack • Deluxe silverware basket
- QuietPower I sound package • Steel door

GSD3200GWW

White on white (not shown)

GSD3200GCC

Bisque on bisque (not shown)



HotStart™ option preheats prior to main wash for great performance every time.



GSD2200GWW White on white

- ENERGY STAR®-qualified • 5 cycles/12 options • Pots & Pans cycle
- HotStart option • Deluxe lower rack • Deluxe silverware basket
- QuietDesign™ sound package • Steel door

GSD2200GCC

Bisque on bisque (not shown)

GSD2200GBB

Black on black (not shown)

GSD2201GWW

White on white (not shown)

- Power cord attached



As an ENERGY STAR® partner, GE has determined that this product meets the ENERGY STAR® guidelines for energy efficiency.



GSD2000GCC Bisque on bisque

- 4 cycles/9 options • HotStart option • Deluxe lower rack • Deluxe silverware basket • Standard sound package • Steel door

GSD1900GWH White with black control panel

GSD2000GWW

White on white (not shown)

GSD2000GAA

Almond on almond (not shown)

GSD2000GBB

Black on black (not shown)

GSD2001GWW

White on white (not shown)

- Power cord attached

GE Disposall®—Food Waste Disposers

Food disposer minimizes plumbing maintenance; good cleaning results without pre-rinsing dishes.



GFC520F

- Continuous feed disposer features • Heavy duty 1/2 HP motor • 2600 RPM grinding action • Large capacity • EZ-Mount installation • Standard sound insulation package
- Removable splash guard

GFC525F

- Similar features and appearance as GFC520F, except has attached line cord.



GFC320F

- Continuous feed disposer features • 1/3 HP motor • 1900 RPM grinding action • Large capacity • EZ-Mount installation • Standard sound insulation package
- Removable splash guard

GFC325F

- Similar features and appearance as GFC320F, except has attached line cord.

GFC329G

- Three-bolt mount adaptable disposer features • 1/3 HP motor • 1900 RPM grinding action • Large capacity
- Standard sound insulation package

Not all features available on all models.

For additional features, specifications and color availability, refer to page 44.

GE Spacemaker® Under-the-Sink Dishwashers

120° F. inlet water capability gives good cleaning results even when water temperature is turned down for safety and energy savings.



Installed under a single sink



Installed under a cooktop

GSM2100GWW White on white

GSM2100GCC Bisque on bisque

- ENERGY STAR®-qualified • 5 cycles/12 options • Two wash levels • Pots & Pans cycle • Normal Wash cycle • Short Wash cycle (on dial) • Plate Warmer cycle (on dial) • Rinse Only cycle (on dial) • HotStart™ option • PermaTuf® tub
- Spacemaker upper rack • Deluxe lower rack • Deluxe silverware basket
- QuietPower™ motor

Note: Under-the-Sink dishwashers can be installed under GE cooktop models JP200V and JP201CV. Refer to cooktop installation instructions.

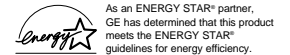

GE Spacemaker® 18" Built-In Dishwasher



GSS1800Z

- 4 cycles/7 options • Two wash levels • Pots & Pans cycle (on dial) • Normal Wash cycle (on dial) • Light Wash cycle (on dial) • Standard silverware basket
- Heated Dry option • Reversible color panels Black, Almond, White

Not all features available on all models.

For additional features, specifications and color availability, refer to page 45.

GE SmartWater™ Water Filtration



SmartWater Faucet—Separate faucet is used only when filtered water is needed, extending filter life.



Simple installation means system can be installed easily under a counter, in a basement, or other convenient location.

Undersink Dual Stage Carbon Drinking Water Filtration



GNSV30C/GNSV25C

- Chemical/VOC lead and cyst reduction filters included (FXSVC dual pack)

Reduces

Chemicals/VOC	Lead	Cysts
Asbestos	Mercury	Chlorine
Taste & Odor	Sediment	Rust



GNSL05C

- Lead and cyst reduction filters included (FXSLC dual pack)

Reduces

Lead	Cysts	Asbestos
Mercury	Chlorine	Taste & Odor
Sediment	Rust	Atrazine

GE SmartWater Softening Systems



Towels are 45% whiter using 1/3 less detergent. Clothes are softer, cleaner and last longer.



Dishes are cleaner, with less soap and hard water spotting.



GXSF27E

- 27,000-grain large capacity helps assure an ample supply of soft water for most moderate use situations.
- Large 200 lb. salt storage helps reduce the need for frequent salt replenishment.
- Extra-wide opening allows easier salt loading.
- Flexible demand-initiated regeneration system assures there's always soft water when you need it. The softener actually "learns" your family's water usage patterns.
- 24-volt electric system is easy to install and maintain.
- Standard-flow 3/4" valve allows simple installation.
- Clear water iron removal removes up to 4 ppm.

Not all features available on all models.

For additional features, specifications and color availability, refer to page 45.

GE® Vertical Packaged Terminal Air Conditioners



All Zonline Vertical and Packaged Terminal Air Conditioners are compatible with GE wall-mounted thermostats for remote operation.

Exclusive GE Features:

- Unique sleeve design makes units easier to install.
- Three-way, slide-out chassis with specially designed case makes maintenance and service quick and easy.
- Electronic Temperature Limiting prevents expensive overheating and overcooling (requires RAVRMS accessory).

Standard Features Include:

- Freeze Sentinel™ guards against freeze damage in unoccupied rooms (requires RAVRMS accessory).
- Central Desk Control capability can reduce operating costs.
- Full Corrosion Treatment on outside coils and other components is standard.
- Ideal for hotels, motels, office buildings, schools and apartments.
- Vertical design to optimize floor space.
- Unit is concealed in a closet with exterior wall, no need to decorate around wall-mounted unit.
- Room appears much more homelike due to the ducted unit.
- Single unit can be used to cool multiple rooms.
- Each unit controlled by a remote wall thermostat.
- Quiet operation further muffled by surrounding walls with insulation and drywall.

Built-In “J” Series: Slope-Top Chassis Only Models



Cool Only Units



Models	BTUH Cooling	Volts	EER	BTUH Electric Resistance Heating	Wall Case
AJCS06LCA	6000	115	9.5	–	RAB46/47/48
AJCS08ACA	8000	115	9.2	–	RAB46/47/48
AJCS10ACA	9900	115	9.2	–	RAB46/47/48
AJCS09DCA	8900/8700	230/208	9.5/9.5	–	RAB46/47/48
AJCS10DCA	9900/9700	230/208	9.2/9.2	–	RAB46/47/48
AJCS12DCA	11,600/11,400	230/208	9.0/9.0	–	RAB46/47/48

Cool Only Units

Offer a variety of capacities to cool many applications.

Heat/Cool Unit

Provides summer cooling, plus supplemental heat for cold weather—units combine air conditioning with electric resistance heat.

Units include attractive room-side grille of high-impact polystyrene.

These units are chassis-only models and require a separately purchased solid-sided wall case (RAB46, RAB47 or RAB48) and exterior grille (RAG13 or RAG14) for installation. Heat Pump models are also available.

Heat/Cool Unit



Models	BTUH Cooling	Volts	EER	BTUH Electric Resistance Heating	Wall Case
AJES12DCA	11,600/11,400	230/208	9.0/9.0	11,600/9,480	RAB46/47/48

Not all features available on all models.

For additional features, specifications and color availability, refer to pages 46 and 47.

Built-In “J” Series: Hi-Mount Chassis Only Models



Cool Only Units



For high-mount installations where control accessibility is difficult, GE offers “J” Series models with controls located in the lower corner of the room-side cabinet.

Units include attractive room-side grille of high-impact polystyrene. Each unit requires a solid-sided wall case (RAB46, RAB47 or RAB48) and exterior grille (RAG13 or RAG14) for installation.

Models	BTUH Cooling	Volts	EER	BTUH Electric Resistance Heating	Wall Case
AJCH10ACA	9900	115	9.2	—	RAB46/47/48
AJCH10DCA	9900/9700	230/208	9.2/9.2	—	RAB46/47/48
AJCH12DCA	11,600/11,400	230/208	9.0/9.0	—	RAB46/47/48

Zoneline®: Heat Pump and Heat/Cool Models

Resistance Heat Models

GE Zoneline packaged terminal units with resistance heat are especially suited for installations where heating demands are moderate.

Heat Pump Models

Zoneline units with heat pump operation offer economical year-round comfort for zonal comfort conditioning, for most temperatures. Heating is provided by a high efficiency heat pump. The heat pump operation is backed up with resistance heat for those times when outdoor temperatures fall below the heat pump capacity.

Deluxe Line

The Deluxe Line is a high efficiency, two fan motors, microcomputer controlled line of cooling with resistance heat, and cooling with heat pump operation and resistance heat backup. Energy savings, plus standard features make these units an excellent value.

Premium Line

The Premium Line features high efficiency, two fan motors, full featured, microcomputer controlled line, cooling with heat pump and resistance heat backup. The microprocessor, with solid state sensors, offers a variety of features for energy savings and reliable operation.

Easy Installation

Zoneline models are designed for easy installation, whether in new construction, renovation or for replacement of old units. Unless specified by code, they require no sub-base and may be installed flush with the finished floor.

All models are adaptable to remote and central desk control. Zoneline units may even be placed in unusual locations, such as transom or common area installations.

Compatibility with existing Zoneline wall cases simplifies retrofit installations. A new chassis simply slides into the already installed wall case. A new matching rear grille should be used.

And the exclusive, Quick Connect power supply kit for Premium Line models, allows the unit to be installed on various amperage circuits.

2500 Series Deluxe Resistance Heat Standard Microcomputer Controls



3500 Series Deluxe Heat Pumps Standard Microcomputer Controls



5500 Series Premium Heat Pumps Highly Featured Microcomputer Controls



Not all features available on all models.

For additional features, specifications and color availability, refer to pages 46 and 47.

Zonline®: Heat Pump and Heat/Cool Models



Note:
230/208 Volt model numbers shown—also available in 265 Volt units.
If you are located in an area close to the seacoast, a special corrosion treated unit (10th character of model number is "C") is available in the 2200 and 3200 Series units. Not available on 5200 Series units.
It is the responsibility of the property owner/manager to determine if any special applications exist, i.e., special ducting or unit closures, that would prevent the unit from operating properly.

2500 Series Deluxe Resistance Heat Standard Microcomputer Controls



Models	Cooling Cap BTUH	EER	Dehumidification pints/hr.	CFM High/Low	Watts
AZ25E07D	7,100/6,900	11.8/11.8	1.7	240/210	610/595
AZ25E07E	7,100	11.8	1.7	240/210	610
AZ25E09D	9,000/8,800	11.5/11.5	2.7	260/230	795/780
AZ25E09E	9,000	11.5	2.7	260/230	795
AZ25E12D	11,700/11,500	10.9/10.9	3.6	270/240	1095/1075
AZ25E12E	11,700	10.9	3.6	270/240	1095
AZ25E15D	14,600/14,300	9.6/9.6	4.5	310/280	1520/1490
AZ25E15E	14,600	9.6	4.5	310/280	1520

Corrosion protection and Dry Air 25 models (except 15,000 BTUH) are also available.

2500 and 3500 Series Deluxe Line

Models are manufactured with fixed heater wattages with the appropriate power cord attached (all 265 volt models are permanently connected). 5.0 KW heaters are not available on 7,000 BTUH models.

Heater Table

Voltage	Heater Amps	Heater Designator	Watts	KWH	Minimum Capacity	BTUH
230/208	11.0/10.0	2	2550/2090	2.55/2.09	15	8,600/7,100
230/208	15.0/13.6	3	3450/2820	3.45/2.82	20	11,700/9,600
230/208	21.7/19.7	5	5000/4090	5.00/4.09	30	17,000/13,900
265	9.6	3	2550	2.55	15	8,600
265	14.0	4	3700	3.7	20	12,600
265	18.9	5	5000	5.0	30	17,000

Heater BTUH	Minimum Circuit Amps	Line Cord Type
All Premium Series units require a Connection Kit determined by available electrical circuit amperage.		
Available Circuit Amp	Kit #	Heater Watts @ 230V
15 Amp circuit	RAK3152	2550
20 Amp circuit	RAK3202	3450
30 Amp circuit	RAK3302	5000

3500 Series Deluxe Heat Pumps Standard Microcomputer Controls



Models	Cooling Cap BTUH	EER	COP	Dehumidification pints/hr.	Watts
AZ35H07D	7,100/6,900	11.8/11.8	3.5/3.5	1.7	610/595
AZ35H07E	7,100	11.8	3.5	1.7	610
AZ35H09D	9,000/8,800	11.5/11.5	3.5/3.5	2.7	795/780
AZ35H09E	9,000	11.5	3.5	2.7	795
AZ35H12D	11,700/11,500	10.9/10.9	3.3/3.3	3.6	1095/1075
AZ35H12E	11,700	10.9	3.3	3.6	1095
AZ35H15D	14,600/14,300	9.6/9.6	3.1/3.1	4.5	1520/1490
AZ35H15E	14,600	9.6	3.1	4.5	1520

Corrosion protection and internal condensate removal models are also available.

5500 Series Premium Heat Pumps Highly Featured Microcomputer Controls



Models	Cooling Cap BTUH	EER	COP	Dehumidification pints/hr.	Watts
AZ55H07D	7,100/6,800	12.0/12.0	3.5/3.5	1.7	590/565
AZ55H07E*	7,100	12.0	3.5	1.7	590
AZ55H09D	9,000/8,800	11.5/11.5	3.5/3.5	2.8	795/780
AZ55H09E*	9,000/8,800	11.5	3.5	2.8	795
AZ55H12D	11,800/11,600	10.9/10.9	3.3/3.3	3.6	1105/1085
AZ55H12E*	11,800/11,600	10.9	3.3	3.6	1105
AZ55H15D	14,700/14,400	10.0/10.0	3.1/3.1	4.8	1470/1440
AZ55H15E*	14,700/14,400	10.0	3.1	4.8	1470

*Indicates unit with ICR to minimize heat pump condensate draining from unit.
Also available on 3200 Series Heat Pump units.

Internal condensate removal models are also available.

Not all features available on all models.

For additional features, specifications and color availability, refer to page 46.



Deluxe quiet design
New design and enhanced components ensure quiet operation.



HTS18BCM



HTS17BCM

HTS18BCM

- 17.9 cubic foot capacity
- Upfront temperature controls
- Two full-width, adjustable wire shelves
- Three fixed door shelves with gallon storage
- Two classic white vegetable/fruit crispers
- Equipped with factory-installed electronic icemaker
- Spill-proof freezer floor
- Deluxe quiet design
- NeverClean™ condenser

HTS18BBM (not shown)

- Similar features and appearance as HTS18BCM without factory-installed electronic icemaker.

HTS17BCM

- 16.9 cubic foot capacity
- Upfront temperature controls
- Two full-width, adjustable wire cabinet shelves
- Two fixed door shelves with tall bottle storage
- Two classic white vegetable/fruit crispers
- Equipped with factory-installed electronic icemaker
- Deluxe quiet design
- NeverClean condenser

HTS17BBM (not shown)

- Similar features and appearance as HTS17BCM without factory-installed electronic icemaker.

Not all features available on all models.
See pages 6 and 7 in GE section for top-freezer refrigerator models.
For detailed features and specifications, refer to page 49.

Hotpoint Top-Freezer Refrigerators

HTR17BBM

- 16.9 cubic foot capacity
- Upfront temperature controls
- Two full-width, adjustable wire shelves
- Two fixed door shelves with tall bottle storage
- Two classic white, vegetable/fruit crispers
- Recessed door handles
- Equipped for optional electronic icemaker
- Deluxe quiet design
- NeverClean condenser

HTS16BCM (not shown)

- 15.6 cubic foot capacity
- Upfront temperature controls
- Two full-width, adjustable wire shelves
- Two fixed door shelves with tall bottle storage
- Two classic white vegetable/fruit crispers
- Equipped with factory-installed electronic icemaker
- Deluxe quiet design
- NeverClean condenser

HTR16BBM (not shown)

- Similar features and appearance as HTR17BBM, except 15.6 cu. ft. capacity.

HTS15BCM (not shown)

- Similar features and appearance as HTS16BCM, except 14.6 cubic foot capacity.

HTS15BBM (not shown)

- Similar features and appearance as HTS16BBM, except 14.6 cubic foot capacity.

HTR15BBM (not shown)

- Similar features as HTS15BBM, except recessed door handles.

HTH15BBM (not shown)

- Similar features as HTR15BBM, except no recessed door handles.

HTR15ABM

- 14.6 cubic foot capacity
- Two full-width, adjustable wire cabinet shelves
- Two fixed door shelves with tall bottle storage
- One full-width, white vegetable/fruit crisper
- Equipped for optional electronic icemaker
- Deluxe quiet design
- NeverClean condenser



HTR17BBM



As an ENERGY STAR® partner, GE has determined that this product meets the ENERGY STAR® guidelines for energy efficiency.

(Model HTH15BBM)



HTR15ABM

Not all features available on all models.

See pages 6 and 7 in GE section for top-freezer refrigerator models.

For detailed features and specifications, refer to page 49.

Hotpoint® Electric Ranges



Lift-up cooktop
Cooktop lifts up to allow easy cleanup of hard-to-reach spots underneath.



Calrod® surface elements
Surface elements simply unplug and remove for easy cleaning of drip bowls.



One-piece upswept cooktop
No cracks or crevices to trap dirt! The porcelain enamel-on-steel surface wipes clean easily.



Easy level system
Design provides an easily accessible leveling system. Simply slide-out storage drawer. Located in the front of each front leg is its leveling adjustment. Upfront adjustment makes leveling range easy and convenient. (Available on model RB525C.)

30" electric ranges with standard and self-cleaning ovens

RB757BC

- White or Bisque model
- Black control panel
- Auto oven shut-off
- Two-step self-clean
- Two 8" and two 6" plug-in Calrod heating elements with one-piece porcelain-enameled drip bowls
- Lift-up cooktop
- Frameless black glass oven door with window
- Designer-style handle

RB753BC (not shown)

- White or Bisque model
- Two 8" and two 6" plug-in Calrod heating elements with one-piece chrome drip bowls
- Frameless black glass oven door
- Designer-style handle

RB525BC

- White or Bisque model
- One 8" and three 6" plug-in heating elements
- Frameless solid black glass oven door
- Chrome visor door handle

RB525C (not shown)

- White or Almond model
- Same features and appearance as RB525BC, except has color-matched painted oven door.



RB757BC
Self-Clean Oven



RB525BC

24" free-standing electric range

RA524W

- Standard clean oven
- One 8" and three 6" plug-in heating elements with chrome drip bowls
- Lift-up cooktop with porcelain-enameled subtop
- Two heating element "ON" indicator lights



RA524W

20" free-standing electric range

RA520W

- Standard clean oven
- One 8" and three 6" plug-in heating elements with chrome drip bowls
- Lift-up cooktop with porcelain-enameled subtop
- Two heating element "ON" indicator lights



RA520W

Not all features available on all models.
See pages 10 and 11 in GE section for electric range models.
For detailed features and specifications, refer to page 49.

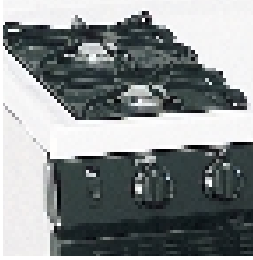

Square grates

Burner grates feature durable porcelain-enameled finish; square design creates a continuous cooking platform.



Lift-up cooktop with easy-clean subtop

Standard burner models have a cooktop that lifts up for easy access to porcelain-enameled subtop. Twin rod supports allow cooktop to lift and lock into place. No pipes or wires to interfere with cleanup.



Extra-large broiler pan/grid

Porcelain-enameled broiler pan and grid are extra large. Allows for extra broiling space.

30" free-standing gas ranges

RGB745WEA (not shown)

- White on white model
- Extra-large, self-clean oven
- Sealed cooktop burners
- Simmer 600 burner
- Performance Plus burner
- Heavy steel grates
- In-oven broiling
- Frameless white glass oven door with window
- EasySet III clock and oven timer
- Removable black porcelain-enameled drip pans
- Storage drawer

RGB745BEA

- White or Bisque model
- Same features as RGB745WEA, except has black control panel and black glass oven door.

RGB528BEA

- White or Bisque model
- Extra-large standard-clean oven
- Frameless black glass oven door with window
- Electronic clock/timer
- Twin cooktop burners
- Lift-up cooktop

RGB524PEA

- Extra-large standard oven
- Solid color-matched porcelain-enameled oven door
- Twin cooktop burners
- Lift-up cooktop
- Slide-out broiler drawer
- Electronic pilotless ignition system

RGB524PPA

- Same features as RGB524PEA, except with standing pilot ignition system.

RGB508PEA

- Extra-large standard oven
- Solid color-matched porcelain-enameled oven door
- Twin cooktop burners
- Lift-up cooktop
- Drop-down broiler drawer
- Electronic pilotless ignition system

RGB508PPA

- Same features as RGB508PEA, except with standing pilot ignition system.



**RGB745BEA
CAPACITY PLUS™**



**RGB528BEA
CAPACITY PLUS™**



RGB524PEA/PPA



RGB508PEA/PPA

Not all features available on all models.
See page 13 in GE section for gas range models.
For detailed features and specifications, refer to page 50.

Hotpoint® Gas Ranges

24" compact gas ranges with standard oven

RGA524EW

- Standard oven
- Electronic pilotless ignition
- Porcelain-enameled oven door
- Recessed, lift-up cooktop
- Round burner grates
- Push-to-turn controls

RGA524PW (not shown)

- Same features as RGA524EW, except with standing pilot ignition system.

20" compact gas ranges with standard oven

RGA520EW

- Standard oven
- Electronic pilotless ignition system
- Porcelain-enameled oven door
- Recessed, lift-up cooktop
- Round burner grates
- Push-to-turn controls

RGA520PW (not shown)

- Same features as RGA520EW, except with standing pilot ignition system.



RGA524EW



RGA520EW/PW

Not all features available on all models.
See page 13 in GE section for gas range models.
For detailed features and specifications, refer to page 50.

Hotpoint Over-the-Range Microwave



The design of the Counter Saver Plus microwave oven complements any kitchen. In the place of a range hood, enjoy the convenience of microwave cooking with eye-level controls directly above your range or cooktop, increasing the livability of your apartment.

Counter Saver Plus™ over-the-range microwave oven

RVM1435BD

- Black on black
- 1.4 cu. ft. oven cavity
- 950 watts*
- Electronic scrolling display with clock and AM/PM pad
- Variable scroll speed
- Concurrent programming
- Turntable
- Instant On controls
- Time Defrost/Auto Defrost
- 10 power levels
- Child lockout
- Full-view cooktop lighting

RVM1435WD (not shown)

- White on white

*IEC-705 Test Procedure



RVM1435BD

Not all features available on all models.
See pages 14 and 15 in GE section for over-the-range microwave oven models.
For detailed features and specifications, refer to page 50.



Balance Pro™ Suspension System

An innovative rod and spring floating suspension system designed to handle off-balanced loads on any type of floor. All Hotpoint washers are 100% front serviceable.



Double-coated drum interior
Provides long-lasting dependability and durability.

Washer and dryer pairs

VBSR3100B

- 3.2 cu. ft. Super capacity washer
- 3 water levels
- 10 cycles
- 3 wash/spin speed combinations
- 3 wash/rinse temperature settings
- FlexCare™ agitator
- Bleach dispenser
- Fabric softener dispenser

VBXR1090B

- 2.7 cu. ft. Extra-large capacity washer
- 3 water levels
- 9 cycles
- 1 wash/spin speed combination
- 3 wash/rinse temperature settings
- FlexCare agitator
- Bleach dispenser

VVSR1070B

- 3.2 cu. ft. Super capacity washer
- 3 water levels
- 7 cycles
- 1 wash/spin speed combination
- 3 wash/rinse temperature settings
- FlexCare agitator

NBXR463EB (Electric) NBXR463GB (Gas)

- 6.0 cu. ft. Extra-large capacity dryer
- Automatic dry control
- 5 cycles
- 4 heat selections
- Up-front lint filter
- Reversible door

NVL333EB (Electric) NVL333GB (Gas)

- 5.7 cu. ft. Extra-large capacity dryer
- Automatic dry control
- 3 cycles
- 3 heat selections
- Up-front lint filter



VBSR3100B



VBXR1090B



VVSR1070B



NBXR463EB/GB



NVL333EB/GB

Hotpoint® Dishwashers

Hotpoint dishwashers offer new features for today's customers



Durable tub and door liner
Guaranteed for ten years against leakage from cracking, peeling, chipping or rusting.

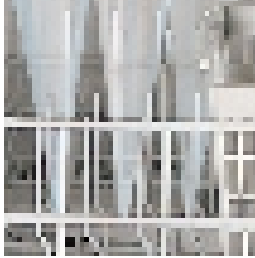

3-Level "Wall of Water"
Completely covers any item in dishwasher, providing excellent wash performance.



Toe kick and access panel insulation
Fiberglass insulation in toe kick and access panel minimizes operating noise.



QuietPower™ motor
A quieter, cooler, more energy efficient motor than previous motors.



Hot Prewash Option
Preheats water prior to main wash for great wash performance every time.



HDA2000GBB
ENERGY STAR® Model

- 4 cycles/9 options
- Heavy Wash cycle (on dial)
- Water Saver cycle (on dial)
- Rinse Only cycle (on dial)
- Heated Dry (on rocker)
- Hot PreWash option (on dial)
- Standard upper rack
- Deluxe silverware basket

HDA2000GWW – White on white
HDA2000GCC – Bisque on bisque
HDA2000GAA – Almond on almond

Available for contract sales only.



As an ENERGY STAR® partner, GE has determined that this product meets the ENERGY STAR® guidelines for energy efficiency.



HDA1000GWH

- 1 cycle/4 options
- Normal Wash cycle (on dial)
- Heated Dry (on rocker)
- Hot Prewash option (on dial)
- Standard upper rack
- Deluxe silverware basket

White body with black control panel.

Not all features available on all models.
See pages 20 and 21 in GE section for dishwasher models.
For detailed features and specifications, refer to page 50.

Top-Freezer No-Frost Refrigerators

	GE "E" Series			GE "D" Series			GE "B" Series			GE "A" Series		
	GTS18EBM	GTH18DBM GTS18DBM	GTS18DCM	GTR18BBM	GTS17BBM GTS17BCM	GTR17BBM	GTS16BBM	GTH15BBM GTS15BBM GTS15BCM	GTR15BBM	GTS12BBM	GTS10AAM	
Capacity												
Total (cu. ft.)	17.6	17.9	17.9	17.6	16.9	16.9	15.6	14.6	14.6	11.7	10.3	
Fresh food (cu. ft.)	13.62	12.89	12.89	13.62	13.05	13.05	11.69	10.77	10.77	8.80	7.95	
Freezer (cu. ft.)	4.01	5.03	5.03	4.01	3.86	3.86	3.86	3.86	3.86	2.90	2.37	
Shelf area (sq. ft.)	20.3	22.6	22.2	18.0	17.5/16.7	17.5	17.2	17.2/17.2/16.4	17.2	13.6	14.0	
Features												
Upfront temperature controls	●	●	●	●	●	●	●	●	●	●	●	
Cabinet shelves (adjustable)	3 (1 F/W wire, 1 split wire, 1 split glass)	3 wire	3 wire	2 wire	2 wire	2 wire	2 wire	2 wire	2 wire	2 wire	2 wire	
Vegetable/fruit crisper(s)	2	2 split, 1 F/W	2 split, 1 F/W	2 F/W	2 F/W	2 F/W	2 F/W	2 F/W	2 F/W	2 F/W	2 F/W	
Snack pan	●	●	●							1 F/W/Divided	1 F/W	
Door shelves	2 (Tall Bottle)	3 w/ gallon storage	3 w/ gallon storage	2 (Tall Bottle)	2 (Tall Bottle)	2 (Tall Bottle)	2 (Tall Bottle)	2 (Tall Bottle)	2 (Tall Bottle)	2 F/W, 1 split	4 (1 Tall Bottle)	
Dairy compartment	●	●	●	●	●	●	●	●	●	●	●	
Interior light system	Single	Single	Single	Single	Single	Single	Single	Single	Single	Single	Single	
Quiet Design	Deluxe	Deluxe	Deluxe	Deluxe	Deluxe	Deluxe	Deluxe	Deluxe	Deluxe	Deluxe	Deluxe	
Automatic moisture control	●	●	●	●	●	●	●	●	●	●	●	
NeverClean™ condenser	●	●	●	●	●	●	●	●	●	●	●	
ENERGY STAR®		● / -						● / - / -			●	
Freezer Features												
Factory-installed electronic icemaker	Opt. (IM4)	Opt. (IM4)	●	Opt. (IM4)	Opt. (IM4) / ●	Opt. (IM4)	Opt. (IM4)	Opt. (IM4) / ●	Opt. (IM4)	Opt. (IM4)	Opt. (IM4)	
Ice 'N Easy trays	2	2		2	2 / -	2	2	2 / 2 / -	2	1	2	
Ice storage bin			Ice Bucket		- / Ice Bucket			- / - / Ice Bucket				
Ice shelf				●	● / -	●	●	● / ● / -	●			
Wire freezer compartment shelves	Step	1 F/W (2 pos.)	1 F/W (2 pos.)								1 F/W	
Fixed door shelves	2	2	2	2	2	2	2	2	2	2	1	
Exterior												
Color(s) available*	WW, CC	WW, CC, BB** WW, CC, AA	WW, CC	WW, CC	WW, CC, AA WW, CC	WW, CC	WW, CC, AA	WW, CC, AA WW, CC	WW, CC	WW, CC	WW	
Door handle(s)	CM	CM	CM	Recessed	CM	Recessed	CM	CM	Recessed	CM	Recessed	
Customer installed handles	●	●	●									
Exterior design	Square Doors	Rounded Doors	Rounded Doors	Square Doors	Square Doors	Square Doors	Square Doors	Square Doors	Square Doors	Rounded Doors	Rounded Doors	
Reversible doors	●	●	●	●	●	●	●	●	●	●	●	
Choose right or left door opening	●	●	●	●	●	●	●	●	●	●	●	
Adjustable rollers	Front	Front	Front	Front	Front	Front	Front	Front	Front	Front	Front	
Weights & Dimensions												
Height to top of hinge (in.) A	67-3/8	66-5/8	66-5/8	67-3/8	67-3/8	67-3/8	64-3/4	61-3/4	61-3/4	60-5/8	58-3/4	
Height to top of case (in.) B	66-7/8	66-1/8	66-1/8	66-7/8	66-7/8	66-7/8	64-1/4	61-1/4	61-1/4	60-1/4	58-1/4	
Case depth without door (in.) C	26-3/4	27-1/2	27-1/2	26-3/4	26-3/4	26-3/4	25-7/8	25-7/8	25-7/8	27-1/2	25	
Case depth less door handle (in.) D	30-1/2	30-1/4	30-1/4	30-1/2	30	30	29-1/8	29-1/8	29-1/8	30-1/4	27	
Case depth with door handle (in.) E	32-3/8	32-1/8	32-1/8	30-1/2	31-7/8	30	31	31	29-1/8	32	27	
Depth w/fresh food door open 90° (in.) F	56-3/8	58-1/8	58-1/8	56-3/8	55-3/4	55-3/4	54-7/8	54-7/8	54-7/8	51-5/8	48-3/4	
Width (in.) G	28	29-1/2	29-1/2	28	28	28	28	28	28	23-3/8	23-5/8	
Width w/door open 90° less door handle (in.) H	28-7/8	30	30	28-7/8	28-5/8	28-5/8	28-5/8	28-5/8	28-5/8	24-1/8	24-1/8	
Air clearances Each side (in.)	3/4	1/8	1/8	3/4	3/4	3/4	3/4	3/4	3/4	3/4	1	
Top (in.)	1	1	1	1	1	1	1	1	1	2	3	
Back (in.)	1	1	1	1	1	1	1	1	1	3/4	1	
Approx. shipping wt. (lbs.)	187	223	228	178	179 / 184	178	166	166 / 166 / 171	165	155	158	

*Color(s) available: WW = White on white, CC = Bisque on bisque, AA = Almond on almond, BB = Black on black, CM = Color-Matched.

**GTS18DBMBB only available with right door opening.

ALL MODELS AVAILABLE IN U.S. AND CANADA.

Top-Freezer No-Frost Refrigerator

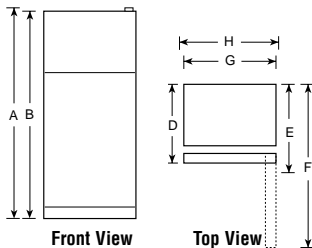

Note: All Top-Freezer No-Frost Right-Hand Refrigerator Doors: As you face the front of the refrigerator, the handle is on your left and the hinges are on your right. All Top-Freezer No-Frost Left-Hand Refrigerator Doors: As you face the front of the refrigerator, the handle is on your right and the hinges are on your left.

Side-By-Side Refrigerator

GE "D" Series	
GSS20DBM	
Capacity	
Total (cu. ft.)	19.8
Fresh food (cu. ft.)	12.75
Freezer (cu. ft.)	7.04
Shelf area (sq. ft.)	18.2
Fresh Food Features	
Upfront electronic temperature controls	●
Cabinet shelves	3 Wire Everwhite
Adjustable	3
Deli pan	1 Sealed
Vegetable/fruit crisper	1 Sealed
Fixed door bins	4 (2 w/ gallon storage)
Dairy compartment	●
Interior light system	Single-level
Quiet Design	Deluxe
Automatic moisture control	●
NeverClean™ condenser	●
Freezer Features	
FrostGuard™ technology	●
Factory-installed electronic icemaker and bin	Opt. (IM5SS)
Wire cabinet shelves	4 (3 Adj.)
Storage bin(s)	1
Door shelves	6
Interior light	●
Appearance	
Color(s) available*	WW, CC
Deluxe door handle(s)	CM
Textured steel door and case	●
Adjustable rollers	Front
Weights & Dimensions	
Height to top of hinge (in.) A	67-1/2
Height to top of case (in.) B	66-1/2
Case depth without door (in.) C	28
Case depth less door handle (in.) D	30-3/4
Case depth with door handle (in.) E	33
Depth with fresh food door open 90° (in.) F	46-9/16
Width (in.) G	31-1/2
Width w/door open 90° less door handle (in.) H	31-1/2
Air clearances Each side (in.)	1/8
Top (in.)	1
Back (in.)	1
Approx. shipping wt. (lbs.)	300

*Color(s) available: WW = White on white, CC = Bisque on bisque, CM = Color-Matched.

Add 9/16" for water hook-up. Hook-up fits in 5/8" back air clearance when calculating installation depth. If installed against a wall, allow clearance of 10-3/4" on 20 cu. ft. models.

To remove fresh food pans, remove door bins.

Clearances required to remove fresh food full-size pan without disassembling: 13-1/2" on 20 cu. ft.

Allow additional space for any necessary leveling adjustments.

ALL MODELS AVAILABLE IN U.S. AND CANADA.

Side-By-Side Refrigerator

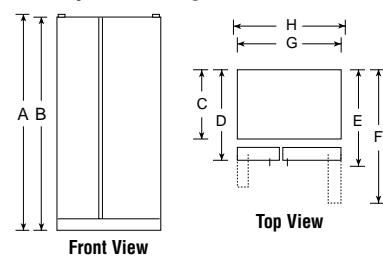

Spacemaker Refrigerator

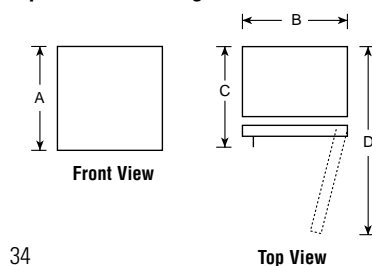

Cycle and Manual Defrost Refrigerators

	GE	
	Cycle Defrost	Manual Defrost
	GFR12AAM	GMS10AAM
Capacity		
Total (cu. ft.)	11.7	9.7
Fresh food (cu. ft.)	9.04	8.74
Freezer (cu. ft.)	2.61	.97*
Shelf area (sq. ft.)	13.9	9.88
Features		
Ice 'N Easy trays	2	2
Freezer chiller tray with baffle	●	●
Cabinet shelves	2 Adj.	2 Adj.
Vegetable/fruit crisper	2	1 F/W
Door shelves	3	5 (2 Egg w/pockets)
Tall bottle storage on door	●	●
Dairy compartment(s)	1 F/W	1
Freezer compartment shelf(s)	1 F/W	1 F/W
Economical/Quiet		
Cabinet/door insulation	Foam	Foam
Cabinet/door liner	Plastic	Plastic
Appearance		
Color(s) available	White	White
Door handle(s)	White Recessed	Black
Reversible doors	●	●
Right or left door opening		●
Weights & Dimensions		
Height to top of hinge (in.) A	59-1/2	58
Height to top of case (in.) B	59-5/16	57-9/16
Case depth without door (in.) C	26	21-3/8
Case depth with door less handle (in.) D	28	23-1/2
Case depth with door handle (in.) E	28	24-13/16
Depth with door open 90° less door handle (in.) F	50-1/8	44-13/16
Width (in.) G	23-1/2	23
Width w/door open 90° less door handle (in.) H	23-1/2	23-1/2
Air clearances Each side (in.)	1/4	5/8
Top (in.)	1	2
Back (in.)	2	1
Approx. shipping wt. (lbs.)	139	135

*Compartment for short-term storage of frozen food. The frozen food compartment of this refrigerator will make ice, and pre-frozen foods can be stored for about **two weeks**. It will not effectively freeze fresh foods or provide long-term storage for meats, poultry, or fish.

Cycle Defrost Refrigerator

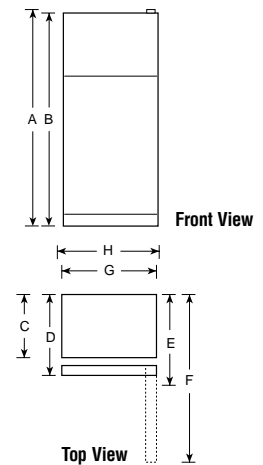

Manual Defrost Refrigerator

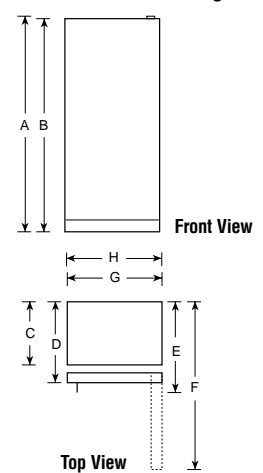

GE Spacemaker™ Compact Refrigerators

	GE		
	GMR06AAM	GMR04BAN	GMR02BAN
Capacity			
Total (cu. ft.)	6.0	4.3	1.7
Fresh food (cu. ft.)	5.51	3.89	1.51
Freezer (cu. ft.)	.49**	.42**	.21**
Shelf area (sq. ft.)	8.8	6.0	2.9
Features			
Ice 'N Easy trays	2 Mini	1 Mini	1 Mini
Manual defrost	●	●	●
Cabinet shelves (wire)	2 Adj.	2-1/2 Adj.	1
Can rack	●	●	●
Door shelves	3 F/W	1 F/W, 2 half-width	1 F/W, 1 half-width
Interior light	●		
Economical/Quiet			
Cabinet/door insulation	Foam	Foam	Foam
Cabinet/door liner	HIPS	ABS	ABS
Appearance			
Color(s) available*	WW	WW, BB	WW, BB
Door handles	White Visor	Color-Matched Recessed	Color-Matched Recessed
Rounded doors	●	●	●
Reversible doors	●		
Weights & Dimensions			
Height (in.) A	34-1/4	33-1/4	18-15/16
Width (in.) B	23-5/8	20-11/16	17-1/2
Depth with handle (in.) C	25-7/8	21-3/4	19-1/4
Depth with door open 90° (in.) D	47-1/2	40-1/4	35-1/2
Air clearances Each side (in.)	0†	1/2	1/2
Top (in.)	1-1/2	2	2
Back (in.)	3/4	2	2
Approx. shipping wt. (lbs.)	88	79	51
Accessories			
Custom trim and black panel	TK6 Optional		

*Color(s) available: WW = White on white, BB = Black on black.

**Compartment for short-term storage of frozen food. The frozen food compartment of this refrigerator will make ice, and pre-frozen foods can be stored for about two weeks. It will not effectively freeze fresh foods or provide long-term storage for meats, poultry, or fish.

†If installed against a wall, allow 1-1/4" on hinge side to allow for proper door opening.

Advantium™ 120 Above-the-Cooktop Ovens

	GE Profile
	SCA1000DWW SCA1000DCC SCA1000DBB
Features	
Stainless steel oven interior	●
Family size oven	●
Cooking modes:	
Speedcook	●
Traditional oven	●
Microwave oven	●
Warming	●
E-Z installation	●
Oven controls:	
Electronic scrolling display	●
Over 100 preprogrammed menu items	●
Repeat last	●
Help mode	●
Demo mode	●
Interior oven light	●
Beeper sound level control	●
Variable scroll speed	●
Custom recipe saver	●
Cooking complete reminder	●
Child lockout	●
Two-speed high-capacity exhaust fan	●
Intake air/grease filter	●
Full-view cooktop lighting	●
Programmable night light	●
Frameless glass oven door w/window	●
Microwave oven features:	
Sensor	●
Defrost - Auto/Time	●
Microwave power output watts	900
Appearance	
Color appearance	White on white Bisque on bisque Black on black
Weights & Dimensions	
Approx. shipping wt. (lbs.)	95
Overall oven interior dimensions (in inches)	
Height	8-7/32
Width	21-3/32
Depth	14-3/32
Overall dimensions (in inches)	
Exterior height (front)	15-21/32
Exterior height (rear)	16-3/32
Exterior width	29-7/8
Exterior depth (not including handle)	14-13/16
Power/Ratings	
Input volt/hertz	120/60
Input amps/watts (max)	15/1800
Accessories	
Cookbook	●
Cooking guide	●
Cooking tray	●
Recirculating charcoal filter kit (optional)	JX81A
Warranty	
Full one-year in-home warranty*	●
Full three-year lamp warranty*	●
Limited ten-year magnetron warranty*	●

*See written warranty for details.

Advantium 120 Above-the-Cooktop Oven Dimensions (in inches)

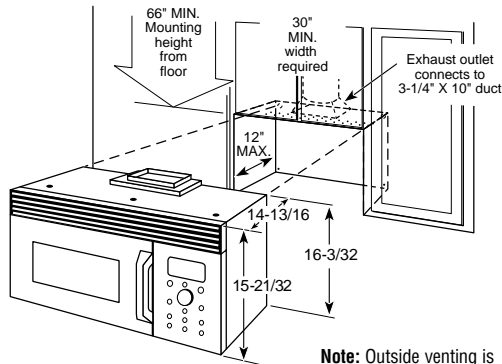

Note: Outside venting is optional. Vent (duct) can be horizontal or vertical.

Built-In Electric Cooktops

Features	GE	
	JP201CB	JP202D
Cooktop surface	Stainless Steel	Porcelain-Enameled
8" heating elements	1 Plug-in	1 Plug-in
6" heating elements	1 Plug-in	1 Plug-in
One-piece removable drip bowls	Chrome	Chrome
Infinite heat rotary controls	●	●
Control panel location	Upfront	Upfront
Surface element "ON" indicator light	●	●
Appearance		
Color appearance*	SS	WW
Weights & Dimensions		
Cooktop width (in inches)	21-1/4	21-1/4
Approx. shipping wt. (lbs.)	18	18
Power/Ratings		
KW rating @ 240V	3.4	3.4
208V	2.5	2.5
Amps @ 240V	20	20
208V	20	20

*SS = Stainless Steel, WW = White on white.

Counter Installation Dimensions (in inches)



Built-In Cooktop Dimensions (in inches)

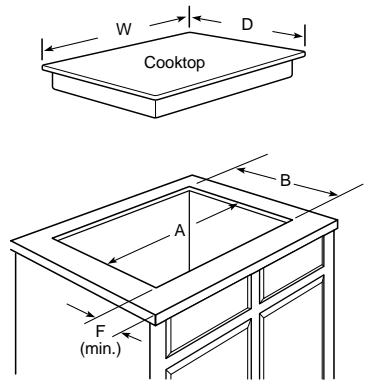

Dimensions (in inches)

Model	Overall		Cutout				Minimum Spacing To Nearest Combustible Wall			To Edge of Front Counter (Min.)
	W	D	A	B	C	R	L	F		
JP202	21-1/4	16-5/8	20-1/8	16-1/8	2	2	2	2-3/4		
JP201	21-1/4	16-5/8	20-1/8	16-1/8	2	2	2	2-3/4		

30" Free-Standing QuickClean™ Electric Ranges

Features	GE									
	JBP26WB	JBP24WB JBP24BB	JBP21BC	JPB21WC	JBS27BC	JBS26C	JBS07C	JBS05Y	JBS03BC JBS03C	
Oven cleaning	Self-Clean	Self-Clean	Self-Clean	Self-Clean	Standard-Clean	Standard-Clean	Standard-Clean	Standard-Clean	Standard-Clean	
Oven capacity (cu. ft.)	5.0	5.0	5.0	5.0	5.0	5.0	5.0	3.7	5.0	
Oven shelves	2	2	2	2	2	2	2	2	2	
Upswept porcelain-enameled cooktop	●	●	●	●	●	●	●		●	
Clean-Well™ cooktop system	●	●	●	●	●	●	●		●	
Lift-up cooktop with dual support rods	●	●	●	●	●	●	●		●	
8" heating elements	2 (5 turns)	2 (5 turns)	2 (5 turns)	2 (5 turns)	2 (5 turns)	2 (4 turns)	1 (5 turns)	1 (4 turns)	1 (5 turns)	
6" heating elements	2 (4 turns)	2 (4 turns)	2 (4 turns)	2 (4 turns)	2 (4 turns)	2 (3 turns)	3 (4 turns)	3 (3 turns)	3 (4 turns)	
Infinite heat controls	●	●	●	●	●	●	●	●	●	
Plug-in Calrod® heating elements	●	●	●	●	●	●	●	●	●	
Removable 1-piece drip bowls	Chrome	Chrome	Chrome	Chrome	Chrome	Chrome	Chrome	Chrome	Chrome	
TrueTemp™ system	●									
SmartLogic™ controls	●									
Six-pass power bake element	●									
Convenience controls		●	●	●						
QuickSet oven controls	QuickSet III	QuickSet II	QuickSet II	QuickSet II						
Digital temperature display	●	●	●	●						
Auto oven shut-off	w/override	w/override	w/override	w/override						
Delay clean option	●									
Auto self-clean	●	●	●	●						
Self-clean cool down display	●	●	●	●						
Audible preheat signal	●	●	●	●						
Clock and minute timer	●	●	●	●	●	●				
Dual element bake	●	●	●	●	●	●	●	●	●	
Heating element "ON" indicator light	●	●	●	●	●	●	●	●	●	
Interior oven light	Switch	Switch	Switch	Switch	Switch	Switch	Switch	Switch		
Preheated oven light	●	●	●	●						
Removable full-width storage drawer	White	White CM**	CM**	CM**	CM**	CM**	White	CM**	CM**	
Broiler pan with grid	●	●	●	●	●	●	●	●	●	
Appearance										
Color appearance*	WW	WW WH/CT White	WH/CT/AD	WW	WH/CT	WH/CT	WW	WH/AD	WH/CT WH/CT/AD Black CM	
Frameless glass oven door*	White	●	Black	White	Black	CM	White	CM	●	
Oven door with window	●	●	●	●	●	●	●	●	●	
Removable oven door	●	●	●	●	●	●	●	●	●	
Designer-style handle	●	●	●	●	●	●	●	Visor	Visor	
Textured steel side panels	●	●	●	●	●	●	●	●	●	
Weights & Dimensions										
Overall oven interior dimensions (WxHxD in inches)	← 24-1/4 x 19 x 19 →		← 23-3/4 x 19 x 18-1/2 →					22-3/4 x 15-3/4 x 17	23-3/4 x 19 x 18-1/2	
Approx. shipping wt. (lbs.)	172	170	144	144	158	159	141	157	154	
Power/Ratings										
KW rating @ 240V	11.7	11.7	11.7	11.7	12.6	11.1	11.5	9.3	11.4	
208V	8.8	8.8	8.1	8.1	9.9	8.8	9.1	6.9	9.0	

*WW = White on White, WH = White, CT = Bisque, AD = Almond, CM = Color-Matched—indicates color oven door or storage drawer matches range cooktop (either Almond or White).

30" Range Hoods

Features	GE	
	JV327X	JN327X
Two-speed fan control	●	●
Vertical exhaust (CFM)	160	
Optional damper accessory (round)	JXDA22	
Sones rating: Top exhaust	8.0	
Removable grease filters	1*	Disposable 1-Pc. Filter*
Filter size (sq. in.)	90	90
Cooktop light(s)**	1	1
7" round duct	●	
Non-vented		●
Appearance		
Color appearance	White, Bisque, Almond White, Bisque, Almond	
Weights & Dimensions		
Approx. shipping wt. (lbs.)	14	19
Power/Ratings		
Current rating amps @ 120V	2.5	2.5

*WB02X9381 replacement grease filter and WB02X10700 replacement charcoal filter are available at additional cost. Call toll-free 800-626-2002.

**Light bulbs not furnished.

30" Slide-In Electric Ranges Spacemaker™ 27" Drop-In Electric Range

Features	GE	
	JSP26BD	JSS16PD
Self-clean oven with Delay Clean option	●	Standard-Clean
Variable cleaning time	●	
Oven shelves	2	2
Lift-up cooktop	White/Bisque	White/Bisque
Overhanging cooktop	●	●
Removable one-piece drip bowls	Chrome	Chrome
Plug-in Calrod™ heating elements	●	●
8" heating elements	2	2
6" heating elements	2	2
Infinite heat controls	●	●
SmartSet Controls	●	●
Temperature display	●	●
Start pad	●	●
Delay Bake option w/Cook & Hold	●	●
C° or F° programmable	●	●
Audible preheat signal	●	●
Auto oven shut-off w/override	●	●
Control lock capability	●	●
Electronic clock and kitchen timer	●	●
Heating element "ON" indicator light	●	●
Interior oven light	●	●
Storage drawer	CM*	CM*
Broiler pan with grid	●	●
Appearance		
Color appearance*	WH/CT	WH/CT
Frameless glass oven door	CM*	Painted
Oven door with window	●	●
Lift-off oven door	●	●
Designer-style handle	●	Visor
Weights & Dimensions		
Overall oven interior dimensions (WxHxD in inches)	← 22-3/4 x 15-3/4 x 17 →	
Approx. shipping wt. (lbs.)	175	160
Power/Ratings		
KW rating @240V	10.8	10.8
208V	8.1	8.1
Amps @ 240V	40	40
208V	40	40
Accessories		
Optional backguard (available at additional cost)	JXS33/31	JXS33/31

*WH = White, CT = Bisque, CM = Color-matched indicates color of the oven door matches range cooktop and drawer face (either almond or white).

Features	GE	
	JMS08BD	
Oven cleaning	Standard-Clean	
Oven shelves	2	
Lift-up overhanging cooktop	White or Bisque Porc.-Enam.	
8" heating elements	1	
6" heating elements	3	
Plug-in Calrod® heating elements	●	
Infinite heat controls	●	
Removable one-piece drip bowls	Chrome	
Heating element "ON" indicator light	●	
Interior oven light	●	
Broiler pan with grid	●	
Appearance		
Color appearance*	WH/CT	
Frameless oven door	Black Glass	
Oven door with window	Big View	
Lift-off oven door	●	
Designer-style handle	●	
Weights & Dimensions		
Overall oven interior dimensions (WxHxD in inches)	19 x 15 x 18	
Approx. shipping wt. (lbs.)	119	
Power/Ratings		
KW rating @240V	10.1	
208V	7.6	
Amps @ 240V	40	
208V	40	

*WH = White, CT = Bisque. Optional backguard in white or black is available at additional cost for all models. JX27RWH = White, JX27RBK = Black.

30" Free-Standing Standard Burner Gas Ranges

Capacity	GE					
	JGBP24BEA	JGBS20BEA	JGBS17PEA	JGBS04BEA JGBS04BPA	JGBS04PEA JGBS04PPA	JGBS03PPA
Extra-large oven	●	●	●	●	●	●
Features						
Oven cleaning	Self-Clean	Standard-Clean	Standard-Clean	Standard-Clean	Standard-Clean	Standard-Clean
Cooktop burners	Std./Twin	Std./Twin	Std./Twin	Std./Twin	Std./Twin	Std./Twin
Valves (degree of turn)	270	140	140	140	140	140
QuickSet oven controls	QuickSet II					
Auto self-clean	●					
Electronic clock and timer	●	●	●			
Audible preheat signal	●					
Auto oven shut-off	●					
Porcelain-enameled cooktop	One-Piece Upswept	One-Piece Upswept	One-Piece Upswept	●	●	●
Lift-up cooktop	●	●	●	●	●	●
Easy-clean porcelain-enameled subtop	●	●	●	●	●	●
Porc.-enam. one-piece drip pans	Opt. Access.	Opt. Access.	Opt. Access.	Opt. Access.	Opt. Access.	Opt. Access.
Removable square grates	Black Standard Porcelain Steel	Black Standard Porcelain Steel	Black Standard Porcelain Steel	Black Standard Porcelain Steel	Black Standard Porcelain Steel	1-Piece Wire
Ignition system	Electronic	Electronic	Electronic	Electronic Standing Pilot	Electronic Standing Pilot	Electronic Standing Pilot
Oven racks	2	2	2	2	2	2
Six embossed rack positions	●	●	●	●	●	●
Extra-large broiler pan/grid	●	●	●	●	●	●
Porcelain-enameled backguard	●	●	●	●	●	●
Interior oven light	●	●	●	●	●	●
In-oven broiling	●					
Slide-out broiler drawer		●	●	●	●	Drop Down
Certified Sabbath mode	●					
Appearance						
Color appearance*	WH/CT	WH/AD	WH/CT	WH/CT	WH/CT	WH/AD
Frameless removable oven door*	Solid Black Glass	Black Glass	CM Porc.-Enam.	Solid Black Glass	CM Porc.-Enam.	CM Porc.-Enam.
Oven door with window		●	●			
Designer-style handle	●	●	●	●	Chrome Visor	Chrome Visor
Four leveling legs	●	●	●	●	●	●
Weights & Dimensions						
Overall oven interior dimensions (WxHxD in inches)	← 24 x 17 x 19 →					
Approx. shipping wt. (lbs.)	200	175	175	165	165	160
Power/Ratings						
Top burners (000's BTU's) Nat/LP	← (4) 9.0/8.0 →					
Oven/broiler burners (000's BTU's) Nat/LP	16.0/16.0 Oven 13.5/12.0 Broil	← 18.0/16.5 →				
Gas range electrical rating **	← 120V, 60Hz., 5A →					
LP conversion kit (included)	●	●	●	●	●	●

*WH = White, CT = Bisque, AD = Almond, CM = Color-Matched indicates color of oven door matches cooktop (either White or Almond). **Electrical rating not applicable to standing pilot models.

Factory set for Natural Gas. A set of LP orifices is included with each XL44™ range for LP conversion.

Spacemaker® Over-The-Range Microwave Ovens

	GE	
	JVM1630WB JVM1631WB* JVM1631CD* JVM1630BB JVM1631BB*	JVM1441WD* JVM1441BD*
Capacity		
Oven cavity (cu. ft.)	1.6	1.4
Features		
Watts (IEC-705 Test Procedure)	1000	950
Electronic touch controls	●	●
SmartControl system w/interactive display	●	●
Scrolling display	1 Line	1 Line
Clock and AM/PM pad	●	●
Variable scroll speed	●	●
Help pad	●	●
Concurrent programming	●	●
Display On/Off	●	●
Convenience controls		
Beverage	●	●
Popcorn	●	●
Reheat	●	●
Express Cook (1-6 min.)	●	●
Instant On controls	●	●
Time Cook	I & II	I & II
Add 30 seconds	●	●
Auto/Time Defrost	●/●	●/●
Power levels	10	10
Delay Start	●	●
Reminder	●	●
CircuWave™ cooking system	●	●
Racks		1
Turntable	●	●
Turntable On/Off	●	●
Full-View cooktop lighting	●	●
Night light	●	●
Timer On/Off	●	●
Cooking complete reminder	●	●
Child lockout	●	●
300-CFM exhaust fan	●	2-Speed
Easy mount installation	●	●
Appearance		
Color appearance**	WW/CC/BB	WW/BB
Case color	White/Bisque/Black	White/Black
Designer-style handle	●	●
Big View window	●	●
Weights & Dimensions		
WxHxD (in inches) Cavity	20-1/4 x 9-9/32 x 14-13/32	19-5/16 x 9-5/16 x 13-3/16
Exterior †	29-7/8 x 16-15/32 (rear) x 15-1/16	29-7/8 x 16-1/2 (rear) x 14-15/16
Approx. shipping wt. (lbs.)	67	67
Power/Ratings		
Frequency (MHz)	2450	2450
Electrical input Watts @ 120V	1480	1480
Amperage	15	15

*Non-vented model.
**Colors available: WW = White on white, CC = Bisque on bisque, BB = Black on black.
†Exterior dimensions: depth excludes handle.

Spacemaker II™ Countertop Microwave Ovens

	GE	
	JEM25WY	JEM25GY
Capacity		
Oven cavity (cu. ft.)	.9	.9
Features		
Watts (IEC-705 Test Procedure)	800	800
Electronic touch controls	●	●
Electronic digital display w/clock	●	●
Beverage/Cook/Popcorn/Reheat/Snacks	●	●
Express Cook	●	●
Instant On controls	●	●
Time Cook I & II	●	●
Add 30 Seconds	●	●
Auto/Time Defrost	●	●
Power levels	10	10
Kitchen timer	99-M./99-S.	99-M./99-S.
Sound On/Off	●	●
Cooking complete reminder	●	●
Delay Start/reminder	●	●
Child lockout	●	●
Appearance		
Door color	White	Black
Case color	White	Greystone
Weights & Dimensions		
Approx. shipping wt. (lbs.)	41	41
WxHxD (in inches) Cavity	16-1/2 x 7-7/16 x 11-1/4	
Exterior †	23-25/32 x 11-3/16 x 12-9/32	
Power/Ratings		
Frequency (MHz)	2450	2450
Electrical input Watts @ 120V	1300	1300
Amperage	11.5	11.5
Accessories		
Hanging kit (Pub. No. 4-A019)*	Optional	Optional
Optional built-in kit	JX827WN	JX827BN/JX827SS

*Pub. No. 4-A019 is available at additional cost.
†Exterior dimensions: height includes feet.

Compact Microwave Ovens

	GE	
	JE740WY/GY	JE520WC/BW
Capacity		
Oven cavity (cu. ft.)	.7	.5
Features		
Watts (IEC-705 Test Procedure)	700	600
Electronic touch controls	●	●
Electronic digital display w/clock	●	●
Beverage/Cook/Popcorn/Reheat/Snacks	●	●
Express Cook	●	●
Instant On controls	●	●
Time Cook	I & II	●
Add 30 seconds	●	●
Auto/Time Defrost	●	-/●
Power levels	10	10
Turntable	●	●
Kitchen timer	99-M./99-S.	
Sound On/Off	●	
Cooking complete reminder	●	
Delay Start/reminder	●	
Child lockout	●	
Appearance		
Color appearance*	WW/BB	WW/BB
Door color	White/Black	White/Black
Case color	White/Greystone	White/Black
Weights & Dimensions		
WxHxD (in inches) Cavity	12-1/16 x 7-11/16 x 12-1/16	11-3/32 x 6-11/16 x 11-7/32
Exterior **	19-1/4 x 10-13/16 x 13-9/16	18-5/32 x 9-19/32 x 12-11/16
Approx. shipping wt. (lbs.)	33	29
Power/Ratings		
Frequency (MHz)	2450	2450
Electrical input Watts @ 120V	1150	950
Amperage	10.5	8.5
Accessories		
Hanging kit (Pub. No. 4-A019) †	Optional	Optional

*WW = White on white, BB = Black on black.
**Exterior dimensions: height includes feet.
†Pub. No. 4-A019 is available at additional cost.

Washers

	GE	
	WCSE4160B	WCSR2080B
Capacity		
Capacity	Super Plus	Super
Cubic feet	3.2	3.2
Features		
Wash/rinse temperatures	3	3
Wash/spin speed combinations	4	2
Water levels	3	3
Fabric softener dispenser	●	
Bleach dispenser	●	●
GentlePower™ Agitator	●	
FlexCare™ Agitator		●
Number of wash cycles	16	8
Cottons Regular		Whites
Extra Heavy Soil	●	
Heavy Soil	●	●
Medium Soil	●	●
Light Soil	●	●
Extra Light	●	●
Auto Soak (15 Min.)	●	
Auto Soak (30 Min.)	●	
Casuals – Pulsed		
Heavy Soil		●
Medium Soil		●
Light Soil		●
Easy Care		
Extra Heavy Soil	●	
Heavy Soil	●	
Medium Soil	●	
Light Soil	●	
Auto Soak (15 Min.)	●	
Delicates		
Medium Soil	●	
Light Soil	●	
Quiet		
Quiet-By-Design™	●	●
Appearance		
Colors available*	WW, CC	WW, CC
Weights		
Approx. shipping wt. (lbs.)	160	160

*Colors available: WW = White on white, CC = Bisque on bisque.

Washer Specifications

Circuit Requirements:

An individual, properly-grounded branch circuit, with a three-prong grounding-type receptacle, protected by a 15- or 20-amp circuit breaker or time-delay fuse is required.

Electrical Rating:

115V, 60Hz, 10A

Washer Note: Washer wall outlet must be located within 36" of service cord entry. Wall outlet must not be located behind dryer.

Dryers

	Electric Gas	GE	
		DBXR463EB DBXR463GB	DBL333EB DBL333GB
Capacity			
Capacity		Extra-large	Extra-large
Cubic feet		6.0	5.7
Features			
Rotary controls		●	●
Automatic Dry control		●	●
Heat selections		4	3
Number of cycles		6	3
Auto Cottons			
Auto Cottons Cycle		●	●
Easy Care			
Auto Easy Care		●	●
Timed Dry			
Actual minutes on timer		80	80
Damp Dry		●	
Dewrinkle		●	
Quick Fluff (no heat)		●	
Dryer interior light		●	
DuraDrum™ interior		●	
Painted steel interior		●	
Quiet			
Quiet-By-Design™		●	●
Appearance			
Colors available*		WW, CC	WW, CC
Weights			
Approx. shipping wt. (lbs.)	Electric	112	125
	Gas	115	130

*Colors available: WW = White on white, CC = Bisque on bisque.
GE electric dryers are available with long-ducting capability.

Dryer Specifications

Exhaust options:

Electric: 4-way via rear, right, left and bottom

Gas: For 6.0 cu. ft. dryers, when viewed from the front of the unit, exhaust 3-way via rear, left and bottom. For 5.7 cu. ft. dryers, when viewed from the front of the unit, exhaust 3-way via rear, right and bottom. Dryer is shipped exhausted to the rear. Alternate exhausting knockouts are supplied.

Circuit Requirements:

Electric: An individual, properly-grounded branch circuit, protected by a 30-amp circuit breaker or a time-delay fuse is required.

Electric Dryer Rating:

208/240V, 5600W, 24A, 60Hz
208V, 4400W, 22A, 60Hz

Gas: An individual, properly-grounded branch circuit, with a three-prong grounding-type receptacle, protected by a 15- or 20-amp circuit breaker or time-delay fuse is required.

Gas Dryer Electric Rating:

120V, 60Hz, 6A

Gas (BTU/HR): 22,000. Factory-equipped for natural gas. Tested for LP gas. LP gas supply requires an optional conversion kit, 5.7 cu. ft. model kit is WE25X10003, 6.0 and 7.0 cu. ft. model kit is WE25X0217. Have a qualified gas technician install a conversion kit. See dryer ducting information for proper installation.

Dryer Note: Dryer wall outlet must be located within 36" of service cord entry and accessible when dryer is mounted in position.

Spacemaker® Portable/Stationary Washer and Dryers

Individual Spacemaker Washers	GE			
	Stationary WLS1100A	Portable WSLP1100A	Stationary WSKS2060W	Portable WSKP2060W
Capacity				
Capacity	Extra-large	Extra-large	Compact	Compact
Features				
Wash/spin speed combinations	1	1	2	2
Wash/rinse temperatures	4	4	3	3
Water levels	4	4	4	4
Number of cycles	10	10	6	6
Cycle countdown	Digital	Digital		
Regular				
Heavy Soil	●	●	●	●
Medium Soil	●	●	●	●
Perm. Press				
Medium Soil	●	●	●	●
Light Soil	●	●	●	●
Delicates	●	●	●	●
Spin only	●	●	●	●
One touch load sensing	●	●		
Automatic cool down	●	●		
Bleach dispenser	●	●		●
Fabric softener dispenser	●	●		
Automatic detergent dispenser	●	●		
Lint filter	2 Removable	2 Removable	●	●
Quiet pump	●	●	●	●
Easy-roll rollers		●		●
Unicouple connector		●		●
Basket material	Stainless Steel	Stainless Steel	PermaTuf II™	PermaTuf II
Appearance				
Colors available*	WW	WW, WH	White with granite-look top	White with granite-look top
Weights & Dimensions				
Circuit requirements	120V, 60 Hertz, 15 or 20 Amps			
Dimensions (HxWxD in inches)**	37-1/2† x 23-5/8 x 26	38 x 23-5/8 x 26	34-1/4 x 22-1/4 x 24	34 x 22-1/4 x 24
Approx. shipping wt. (lbs.)	114	116	109	109

*Colors available: WW = White on white, WH = White with black controls.
 **Depth measured from front of control knob.
 †With leveling legs extended.

Individual Spacemaker Dryers	GE	
	Stationary DSKS433EB	Portable/Stationary DSKP233EW*
Capacity		
Capacity	Compact	Compact
Features		
Dry control	Automatic	Automatic
Heat selections	4	2 (timer)
Number of dry cycles	3	3
Auto. Reg.–Perm. Press		●
Auto. Perm. Press & Delicate	●	
Auto. Reg.	●	
Timed Regular (min.)	140	105
Air Fluff (min.)	(Heat Selection)	10
Separate start switch	●	●
Control location	Mid-Band	Top
End-of-cycle signal		●
Lint filter	Uprfront	Back of Drum
Appearance		
Colors available**	WW	WH
Weight & Dimensions		
Exhaust options***	4-Way 240/208V†, 60 Hertz, 30 Amp	Rear 120V, 60 Hertz, 30 Amp
Circuit requirements	60 Hertz, 30 Amp	60 Hertz, 30 Amp
Power cord	No cord	6 feet
Dimensions (HxWxD in inches)	33-1/4 x 23-7/8 x 24-1/2	32 x 23-7/8 x 23-5/8
Approx. shipping wt. (lbs.)	108	100

*Dryer comes equipped with casters and stationary leveling legs. DSKP233EW is approved for DSR24RW only.
 **WW = White on white, WH = White with black controls.
 ***DSKS433EB shipped exhausted through the top. DSKP233EW exhausted to rear only.
 †240/208 volt outlet: Rear-mounted outlet on DSKS433EB approved for use with Washer/Dryer Stack Rack DSR24RW or DSLR24AW.
Circuit Requirements: An individual, properly-grounded branch circuit of the proper voltage and frequency as specified on the rating plate, with no other appliances or fixtures in circuit, is required.

Commercial Front-Loading Washer/Matching Dryer

Capacity	GE
	WCCH404VWW
Capacity (cu. ft.)	16 pound (2.7—3.1 per IPC)
Features	
Efficiency	ENERGY STAR Rated
Wash/Rinse Temp.	3/1
Automatic Water Levels	●
Wash Program	Std. Wash + 3 rinses (26 min. excl. fill times)
Wash Options	
Color Cottons	●
Permanent Press	●
White Cottons	●
Delicates	●
Extraction	850rpm/210 G's
Automatic Dispensing Opt.	Detergent, Liquid Bleach, Fabric Softener
Suspension	Soft Mount
Drain Pump	13 gpm @ 36 in head
Leveling System	Front Leveling Legs/ Rear Rollers
Wash Drum	Stainless Steel
Door Style	Glass
Appearance	
Color available	White
Control panel	Brushed alum./ black/burgundy
Weights & Dimensions	
Dimensions (HxWxD inches)	36 x 26-3/4 x 24-3/4 (without coin box)
Approx. shipping weight (lbs.)	217
Power Ratings	
Electrical Requirements	120v, 60hz, 12.0 amps

Note: Coin Box Requires assembly to washer, per enclosed Pub. No. 31-15484. Includes accumulator. Coin slides, drops, or smart card accessory must be ordered from supplier separately.

Washer Dimensions (in inches)

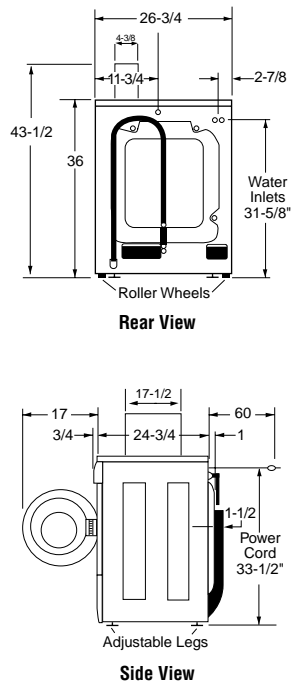

Capacity	GE
	DCCH43EA/GA
Cubic feet	Extra-large (5.7)
Features	
Heat selections	3
Dry cycles	3
High Heat	●
Medium Heat	●
Low Heat	●
Lockable lint filter	●
Door swing	Reversible
Drum finish	White DuraDrum™
Front serviceable	●
Appearance	
Colors available	White
Control panel	Brushed alum./ Black/Burgundy
Weights & Dimensions	
Approx. shipping weight (lbs.)	Electric 116 Gas 116

Dryer Dimensions (in inches)

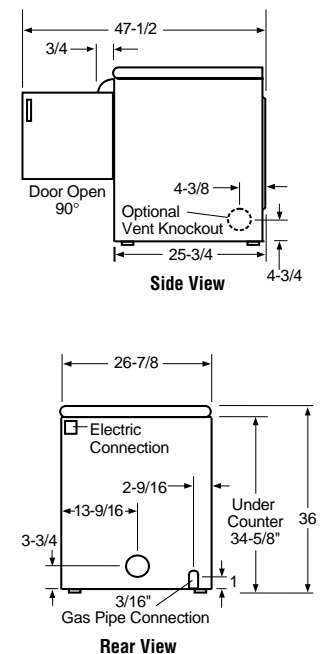

Front-Loading Washer/Matching Dryer

	GE
Washer	WSXH208A
Capacity	
Capacity	Extra-large
Cubic feet	2.7/3.1 IEC
Features	
Wash/rinse temperatures	4
Water levels	Automatic Adjustment
Standard rinse cycles	3
Motor speeds	Variable
Combinations*	HC, WW, WC, CC
Detergent dispenser (liquid/powder)	●
Bleach dispenser	●
Fabric softener dispenser	●
End-of-cycle signal	Adjustable
Final spin/speed selections	Automatic
Number of wash cycles	8
Cotton	
Heavy Soil	●
Medium Soil	●
Light Soil	●
Easy Care	
Medium Soil/Perm. Press	●
Delicates/Ultra Care	●
Pre-Wash	●
Extra-Rinse Cycle/Auto Option	2
Leveling legs	●
Rear rollers	●
Stainless steel wash drum	●
Appearance	
Color available	White on white
Weight	
Approx. shipping wt. (lbs.)	217
Flexible installation	Undercounter, Stacked, Side-by-Side

*HC = Hot-Cold, WW = Warm-Warm, WC = Warm-Cold, CC = Cold-Cold.

	GE
Dryer	DSXH43EA/GA
Capacity	
Capacity	Extra-large
Cubic feet	5.7
Features	
Tumble drying	●
Time Dry cycles	1
Auto Dry cycles	2
Temperature options	4
Regular/Cotton	●
Medium/Perm. Press	●
Low/Delicates	●
Air Fluff/No Heat (Cool Down)	●
Drying rack	●
Auto Dry cycles	
Cottons	●
Easy Care	●
Cool Down	●
Quick Clean lint screen	●
End-of-cycle signal	Adjustable
Drum light	●
Reverse-A-Door	●
Dura Finish top and drum	●
Spill-Saver top	●
Poly tumbling vanes	●
Leveling legs	●
Total front serviceability	●
Exhaust options (Electric/Gas)	4/3
Heavy-duty suspension system	●
Appearance	
Color available	White on white
Weights & Dimensions	
Dimensions (HxWxD in inches)	36 x 26-7/8 x 25-3/4
Approx. shipping wt. (Elec/Gas)	116
Flexible installation	Undercounter, Stacked, Side-by-Side

Electrical Requirements: 120/240V, 3 wire, 5600W, 24A
120/208V, 3 wire, 4400W, 22A

Gas Requirements: 120V, 60Hz, 6A

Front Loading Installation Information

Undercounter Installation

• Accessory mounting kits are required for undercounter installation. To order, call 1-800-848-7722.

Washer—Order Pub. No. 14-A037

Dryer—Order Pub. No. 14-A008

Stacked Installation

• Brackets for stacking dryer over washer are included with the dryer.

Dryer Exhausting Information —

Excluding DSXH43EA/GA

For complete information see installation instructions packed with dryer.

Ducting Materials

For best performance, this dryer should be vented with 4" diameter all rigid metal exhaust duct. If "all rigid metal" duct cannot be used, then "flexible all metal" venting can be used, but it will reduce the maximum recommended duct length. The following kit or parts are available from your local service organization.

Kit WX8X75—7" aluminum duct and 4' hood, short tail. (OR individual parts):

WX8X65 7" aluminum flex duct only

WX8X58 4" clamps (2)

WX8X67 4" exhaust hood

See installation instructions for complete information.

Exhaust length calculation:

1. Determine the number of 90° turns needed for your installation. If you exhaust to the side or bottom of dryer, add one turn.

2. The maximum length of 4' rigid (aluminum or galvanized) duct which can be tolerated is shown in the table. The maximum lengths for flexible ducts are less than for rigid duct. See table in installation instructions. A turn of 45° or less may be ignored. Two 45° turns within the duct length should be treated as a 90° elbow. A turn over 45° should be treated as a 90° elbow.

Dryer Specifications

Exhaust length calculation:

Undercounter Installation

• **Electric:** 4-way via rear, right, left and bottom.

Gas: 3-way via rear, right and bottom. Dryer is shipped exhausted to the rear.

Exhaust Elbow Kit: Order Pub. No. 14-A018.

See installation instructions for alcove, closet, bathroom or bedroom installations.

Exhausting the dryer to the outside is strongly recommended

to prevent large amounts of moisture and lint from being blown into the room. Gas dryers or any dryer located in a closet **must** be exhausted to the outside.

Caution: For personal safety do not terminate exhaust into a chimney, under any enclosed house floor (crawl space), or into an attic, since the accumulated lint could create a fire hazard or moisture could cause damage. Never terminate the exhaust into a common duct or plenum with a kitchen exhaust, since the combination of lint and grease could create a fire hazard.

Exhaust ducts should be terminated in a dampered wall cap to prevent back drafts, bird nesting, etc. The wall cap must also be located at least 12" above the ground or any other obstruction with the opening pointed down. Other terminations, such as louvered wall boxes, are acceptable provided they are equivalent to a 4" opening dampered wall cap.

Unitized Spacemaker® Washers and Dryers

	GE			
	Electric		Gas	
	WSM2700W	WSM2420T	WSM2780W	WSM2480T
Washer	Washer	Dryer	Washer	Dryer
Capacity				
Capacity	X-Large	X-Large	Compact	Compact
Features				
Wash/spin speed combinations	1		2	
Wash/rinse temperatures	3		3	
Water levels	3		3	
Number of wash cycles	3		3	
Regular	●		●	
Perm. Press	●		●	
Delicates	●		●	
Unbalanced load control	●		●	
Lint filter	●		●	
Dryer				
Features				
Automatic dry control		●		●
Number of dry cycles		4		4
Auto Regular		●		●
Auto Perm Press				●
Delicates		●		
Timed		●		●
Air Fluff		●		●
Control location		Mid-Band		Mid-Band
Exhaust options		Rear		Rear/Sides
Appearance				
Colors available*	WW, CC WW		WW, CC WW	
Weight & Dimensions				
Dimensions (HxWxD in inches)	75-1/2 x 27 x 30-13/16**		71-3/4 x 23-7/8 x 27-1/4**	
Approx. shipping wt. (lbs.)	300		238	

*WW = White on white, CC = Bisque on bisque.

**Depth dimension assumes water hook-up is recessed in the wall.

Note: The third prong on the WSM2780W plug configuration is a flat spade type rather than a typical round probe. It requires a matching wall outlet.

Electrical Requirements

WSM2700W: Electric Dryer—This appliance should be connected to an individual, properly-grounded branch circuit with 120/240V or 208V single-phase 60 Hz electrical service and should be protected by 30-amp time-delay fuses or circuit breakers. This appliance is manufactured with neutral connected to the frame. Power cord should be purchased separately.

WSM2420T: Electric Dryer—This appliance should be connected to an individual, properly-grounded branch circuit with 120/240V single-phase 60 Hz electrical service and should be protected by 30-amp time-delay fuses or circuit breakers. This appliance is manufactured with the neutral connected to the frame. Power cord should be purchased separately.

NOTE: THESE APPLIANCES ARE NOT APPROVED FOR 120-VOLT OPERATION.

WSM2480T: Gas Dryer—This appliance should be connected to an individual, properly-grounded branch circuit with a three-prong grounding-type receptacle and 120-volt single-phase 60 Hz electrical service and should be protected by 15- or 20-amp time-delay fuses or circuit breakers. This appliance is equipped with a 6-foot long flexible U.L. listed 20-amp power cord to match a 15-amp receptacle.

Gas Rated input 10,500 BTU/HR. Factory equipped for natural gas. Tested for LP gas.

WSM2780W: Gas Dryer—This appliance should be connected to an individual branch circuit with 120-volt single-phase 60 Hz electrical service and should be protected by 20-amp time-delay fuses or circuit breakers. This appliance is equipped with a 4-foot long flexible U.L. listed 20-amp power cord to match a 20-amp receptacle.

Gas Rated input 20,000 BTU/HR. Factory equipped for natural gas. **LP gas supply requires a conversion kit.**

Kits: WSM2780W – WE25X209

WSM2480T – WE25X0219

Have a qualified gas technician install a conversion kit before use.

For complete information see installation instructions packed with the product.

See installation instructions packed with product for alcove or closet installations.

Commercial Washers and Dryers

	GE Washers	
	WCCD2050B	WCCB1030B
Capacity		
Capacity (cu. ft.)	Extra-large (2.7)	Extra-large (2.7)
Features		
LED cycle countdown	●	
Wash/spin speed combinations	2	1
Wash/rinse temperatures	3	3
Water levels	3 adjustable	3 adjustable
GentlePower™ Agitator	●	●
Self-cleaning filter	●	●
PermaTuf II™ Basket	●	●
Number of wash cycles	5	3
Cottons White	●	●
Cottons Colored	●	●
Permanent Press	●	●
Delicates	●	●
Bright Colors	●	●
Color lid instructions	●	●
100% front serviceable	●	●
1/2 HP motor	●	●
Appearance		
Colors available*	WH, CC	WH, CC
Weight & Dimensions		
Approx. shipping wt. (lbs.)	174	174
Dimensions (HxWxD in inches)	42 x 27 x 25-1/2	42 x 27 x 25-1/2

*WH = White, CC = Bisque on bisque.

Energy Saving:

All wash cycles include energy-saving cold water rinse. Connector in backsplash can be joined for warm rinse. Total cycle time—18-1/2 minutes plus fill time. Actual wash time is 7 minutes with a final spin speed of approximately 630 RPM.

Circuit Requirement:

An individual, properly grounded 15- or 20-amp branch circuit is required.

Electrical Rating: 115V, 60Hz

See Pub. No. 31-15400 for installation instructions.

Note: Coin slide or coin drop, coin vault, and locks for cover and meter case access door are not provided with washer.

Low Water Consumption

Cycle Selection	Total
High Water Level	35 gallons
Medium Water Level	32 gallons
Low Water Level	29 gallons

	Electric Gas	GE Dryers	
		DCB330EB DCB330GB	DCD330EB DCD330GB
Capacity			
Capacity (cu. ft.)		Extra-large (5.7)	Extra-large (5.7)
Features			
LED cycle countdown		●	
Automatic dry control		●	●
Porcelain drum interior		●	●
Upfront lint filter		●	●
Reverse-A-Door		●	●
Heat selections		3	3
Number of cycles		3	3
Cottons		●	●
Permanent Press		●	●
Synthetic Knits		●	●
Front serviceable		●	●
100% front serviceable		●	●
Heavy-duty 1/4 HP motor		●	●
Appearance			
Colors available*		WH, CC	WH, CC
Weights & Dimensions			
Approx. shipping wt. (lbs.)	Electric	140	140
	Gas	155	155
Dimensions (HxWxD in inches)		42 x 27 x 25-1/2	42 x 27 x 25-1/2

*WH = White, CC = Bisque on bisque.

GE electric dryers are available with long-ducting capability.

Exhaust Options: Electric:

4-way venting: left, right, bottom and rear. Maximum recommended exhaust duct length is 45 feet of 4" rigid ducting with two 90° elbows and 4" dampered wall cap.

Gas: 3-way venting: left, bottom and rear. Maximum recommended exhaust duct length is 15 feet of 4" rigid ducting with two 90° elbows and a dampered wall cap.

Dryer is shipped with exhaust to the rear. (See Installation Instructions.)

See Pub. No. 31-1746 for installation instructions.

Circuit Requirements:

Electric An individual branch circuit fused for 30 amps is required for each dryer.

Electric Dryer Rating:

208/240V, 60Hz, 5600W, 24A

208V, 60Hz, 4400W, 22A

A special 208-volt heater, part number WE11X0101 is available to reduce drying time in 208 Volt installations.

Gas: An individual branch circuit fused for 15- or 20-amp is required for each dryer.

Gas Dryer Rating: 115V, 60Hz

Gas (BTU/Hr): 22,000. Factory equipped for natural gas. Tested for LP gas. A conversion kit is required for LP gas. Check installation instructions for correct kit number. Have a qualified technician install the conversion kit. Equipped with energy saving Glo-Bar ignition.

Dryer Note: Dryer wall outlet must be located within 36" of service cord entry and accessible when dryer is mounted in position.

Note: Dimensions and specifications shown here are correct at the time this sheet was printed. Before proceeding with construction or rough-in, check installation instructions that came with your unit. Specifications, dimensions and design are subject to change without notice.

Stackable Commercial Dryers

	GE Dryers	
	Electric	Gas
Capacity		
Capacity (cu. ft.)	Large (5.4)	
Features		
Automatic dry control	●	
Porcelain drum interior	●	
Upfront lint filter	●	
Heat selections	3	
Number of cycles	3	
Cottons	●	
Permanent Press	●	
Delicates/Synthetic/Knits	●	
100% front serviceable	●	
Reverse-A-Door	●	
Heavy-duty 1/4 HP motor	●	
Appearance		
Colors available	White	
Weight & Dimensions		
Approx. shipping wt. (lbs.)	Electric	275
	Gas	275
Stacked (HxWxD in inches)	77 x 27 x 27	

Exhaust Options:

Electric: 3-way venting: left, right, or rear. Maximum recommended exhaust duct length is 25 feet of 4" rigid ducting with two 90° elbows and 4" dampered wall cap.

Gas: 2-way venting: left, or rear. Maximum recommended exhaust duct length is 15 feet of 4" rigid ducting with two 90° elbows and a dampered wall cap.

Dryer is shipped with exhaust to the rear. (See Installation Instructions.)

Circuit Requirements:

Electric: An individual branch circuit fused for 30 amps is required for each dryer.

Electric Dryer Rating:

208/240V, 60Hz, 5600W, 24A

208V, 60Hz, 4400W, 22A

A special 208-volt heater, part number WE11X0101 is available to reduce drying time in 208-volt installations.

Gas: An individual branch circuit, properly grounded for a 3-prong outlet, fused for 15- or 20-amp is required for each dryer.

Gas Dryer Rating: 115V, 60Hz

Gas (BTU/Hr): Maintains thermostatically controlled heat flow to dry clothes gently. Longer cool down period on Permanent Press cycle helps prevent heat-set wrinkles. Separate thermostat controls lower temperatures for Knit cycle drying.

Factory equipped for natural gas. Tested for LP gas. A conversion kit is required for LP gas. Check installation instructions for correct kit number. Have a qualified technician install the conversion kit.

See Pub. No. 31-1723 for DDC4400S and Pub. No. 31-1724 for DDC4500S installation instructions.

Note: Dimensions and specifications shown here are correct at the time this sheet was printed. Before proceeding with construction or rough-in, check installation instructions that came with your unit. Specifications, dimensions and design are subject to change without notice.

Note: Wall anchor chain provided for gas models only.

Non-Coin-Op Commercial Washer and Dryer

	GE Washer	
	WNCD2050A	
Capacity		
Capacity (cu. ft.)	Super Plus (3.2)	
Features		
Wash/spin speed combinations	3	
Wash/rinse temperatures	3	
Water levels	4	
Digital cycle countdown	●	
Number of wash cycles	5	
White cottons	●	
Colored cottons	●	
Bright colors	●	
Permanent Press	●	
Delicate	●	
Spin only	●	
Bleach dispenser	●	
Fabric softener dispenser	●	
Quiet package	Deluxe Quiet Plus	
Lid instructions	●	
LED indicators	●	
Appearance		
Colors available	White	
Weights & Dimensions		
Approx. shipping wt. (lbs.)	160	

	GE Dryer	
	DNCD450EA/GA	
Capacity		
Capacity (cu. ft.)	Super (7.0)	
Features		
Dry cycles	5	
Cottons/high heat	●	
Mixed loads/high heat	●	
Perm press/medium heat	●	
Knits/low heat	●	
Delicates/extra low heat	●	
Temperatures	4	
Air Dry	●	
Digital cycle countdown	●	
Quiet package	Hush	
Lockable lint filter	●	
LED indicators	●	
Door swing	Reversible	
Drum lamp	●	
Drum material	White DuraDrum™	
Appearance		
Colors available	White	
Weights & Dimensions		
Approx. shipping wt. (lbs.)	125	

Commercial Smart Card Washers and Dryers

	GE Washers	
	WNCJ2050AWC	WNCK2050AWC
Capacity		
Capacity (cu. ft.)	Extra-large (2.7)	
Features		
Motor speed	2	
Wash/spin speed comb.	3	
Wash/rinse temperatures	3	
Water levels	4 Adjustable	
Digital cycle countdown	●	
Number of wash cycles	5	
White cottons	●	
Colored cottons	●	
Bright colors	●	
Permanent Press	●	
Delicate	●	
Quiet package	●	
Lid instructions	●	
LED indicators	●	
Smart Card Features		
SmartLaundry™ Reader	BridgePoint	
Alphanumeric display	●	
Control card	●	
Appearance		
Colors available	White	
Control panel	Brushed alum./ black/burgundy	
Weights & Dimensions		
Approx. shipping wt. (lbs.)	170	
Dimensions (HxWxD in inches)	← 42 x 27 x 25-1/2 →	

	GE Dryers	
	DNCJ440EA/GA	DNCK440EA/GA
Capacity		
Capacity (cu. ft.)	Super (7.0)	
Features		
Heat selections	4	
Dry cycles	4	
High Heat	●	
Medium Heat	●	
Low Heat	●	
Cool down	w/High Heat	
Digital cycle countdown	●	
Quiet package	●	
Lockable lint filter	●	
LED indicators	●	
Door swing	Reversible	
Drum finish	White DuraDrum™	
Smart Card Features		
SmartLaundry™ Reader	BridgePoint	
Alphanumeric display	●	
Control card	●	
Appearance		
Colors available	White	
Control panel	Brushed alum./ black/burgundy	
Weights & Dimensions		
Approx. shipping wt. (lbs.)	130	
Dimensions (HxWxD in inches)	← 42 x 27 x 25-1/2 →	

Built-In Dishwashers

GE				
	ENERGY STAR		ENERGY STAR	
	GSD3200GWW GSD3200GCC GSD3200GBB	GSD2200GWW* GSD2200GCC GSD2200GBB	GSD2000GWW* GSD2000GCC GSD2000GAA GSD2000GBB	GSD1900GWH
Features				
Wash system	PowerScrub™	Standard	Standard	Standard
Wash levels	5	2	2	2
Water filtration	Dual			
Food disposer	Piranha™	●	●	●
Cycles	5	5	4	4
Pots & Pans	●	●		
Heavy Wash			Dial	Dial
Normal Wash	●	●	Dial	Dial
Short Wash	Dial	Dial	Dial	Dial
Plate Warmer	Dial	Dial		
Rinse Only	Dial	Dial	Dial	Dial
Options	22	12	9	9
Heated Dry	●	●	Rocker	Rocker
Racks, shelf & basket				
Upper rack	Deluxe	Standard	Standard	Standard
Lower rack	Deluxe	Deluxe	Deluxe	Deluxe
Silverware basket	Deluxe	Deluxe	Deluxe	Deluxe
Control type	Turn-to-start	Turn-to-start	Turn-to-start	Turn-to-start
Cycle progress indicator(s)	Dial	Dial	Dial	Dial
Pushbuttons	6	4		
Rinse aid dispenser	●	●	●	●
Steel door	●	●	●	●
Center throw door latch	●	●	●	●
Quiet				
Quiet				
Sound insulation package	QuietPower I	QuietDesign™	Standard	Standard
PermaTur™ tub/door liner	●	●	●	●
QuietPower™ motor	●	●	●	●
Appearance				
Colors available*	WW, CC, BB	WW, CC, BB	WW, CC, AA, BB	WH
Color panels—door & access	Trimless	Trimless	Trimless	Trimless
Weights & Dimensions				
Approx. shipping wt. (lbs.)	80	80	80	80
Height w/legs retracted (in.)	34	34	34	34
Overall width (in.)	24	24	24	24
Overall depth (in.)	25-3/4	25-3/4	25-3/4	25-3/4
Accessories				
Requires kit for 1/4" panel capability with trim	GPF325W/C/B	GPF325W/C/B	GPF325W/C/A/B	GPF325W
Requires kit for trimless 3/4" panel capability	GPF375	GPF375	GPF375	GPF375

All GE dishwashers are equipped with the following: 120° inlet water capability, Easy-Glide roller system, convection drying, horizontal mechanism, leveling screws.

*GSD2201GWW and GSD2001GWW available with power card attached.

**Colors available: WW = White on white, CC = Bisque on bisque, AA = Almond on almond, BB = Black on black, WH = White body with black control panel.

Disposall® Food Waste Disposers

GE					
	Continuous Feed Models				Three-Bolt Adaptable
	GFC520F	GFC525F	GFC320F	GFC325F	GFC329G
Features					
Motor horsepower	1/2	1/2	1/3	1/3	1/3
Control method	Wall Switch	Wall Switch	Wall Switch	Wall Switch	Wall Switch
Feed type	Continuous	Continuous	Continuous	Continuous	Continuous
Power connection	Direct Wire	Line Cord	Direct Wire	Line Cord	Line Cord
Impellers	Dual swivel	●	●	●	●
Jam resistant	●	●	●	●	●
Stainless steel	●	●	●	●	●
Armature shaft material	Cold-rolled Carbon Steel	Cold-rolled Carbon Steel	Cold-rolled Carbon Steel	Cold-rolled Carbon Steel	Cold-rolled Carbon Steel
Grinding speed (RPM's)	2,600	2,600	1,900	1,900	1,900
Capacity	Large	Large	Large	Large	Large
Mounting type	EZ-Mount	EZ-Mount	EZ-Mount	EZ-Mount	3-Bolt Mount Adapter
Turntable material	Galv. Steel	Galv. Steel	Galv. Steel	Galv. Steel	Galv. Steel
2-level precutter	●	●	●	●	●
Stainless steel sink flange	●	●	●	●	●
Manual reset overload protector	●	●	●	●	●
Splash guard	●	●	●	●	●
Sink stopper	●	●	●	●	●
Dishwasher drain connector	●	●	●	●	●
Drain elbow	●	●	●	●	●
Quiet					
Sound insulation package	Standard	Standard	Standard	Standard	Standard
Weights & Dimensions					
Approx. shipping wt. (lbs.)	8.8	9.1	8.4	8.7	8.0
Net wt. (lbs.)	7.8	8.1	7.4	7.7	7.4
Dishwasher inlet diameter (in.)	3/4	3/4	3/4	3/4	3/4
Drain outlet diameter (in.)	1-1/2	1-1/2	1-1/2	1-1/2	1-1/2
Power Ratings					
Volts, Hertz, Amps	120, 60, 4.5	120, 60, 4.5	120, 60, 4.0	120, 60, 4.0	120, 60, 4.0

Spacemaker® Undersink Dishwasher

GE	
ENERGY STAR GSM2100GWW GSM2100GCC	
Features	
Wash levels	2
Food disposer	●
Cycles	5
Pots & Pans	●
Normal Wash	●
Short Wash	Dial
Plate Warmer	Dial
Rinse Only	Dial
Options	12
Heated Dry	●
HotStart™	Dial
Racks, shelf & basket	
Upper rack	Spacemaker
Lower rack	Deluxe
Silverware basket	Deluxe
Control type	Turn-to-start
Cycle progress indicator	Dial
Pushbuttons	4
Rinse aid dispenser	●
Steel door	●
Center throw door latch	●
Quiet	
PermaTuF™ tub and door liner	●
QuietPower™ motor	●
Appearance	
Colors available*	WW, CC
Color panels—door & access	Trimless
Weights & Dimensions	
Approx. shipping wt. (lbs.)	72
Height w/legs retracted (in.)	34
Overall width / Overall depth (in.)	24 / 25-3/4

*Colors available: WW = White on white, CC = Bisque on bisque, control panel/Bisque on bisque, front panels.

Stainless Steel Sinks Single and Double Compartment Models (Dimensions in Inches)

Model Number	Overall Size		Inside Each Compartment		
	L	W	L	W	D
GPF95 (Single Bowl, R)*	25	21-1/4	21	15-3/4	5-3/8
GPF96 (Single Bowl, L)*	25	21-1/4	21	15-3/4	5-3/8
GPF97 (Double Bowl)	33	21-1/4	14	15-3/4	5-3/8

Model Number	Cutout in Countertop 1-1/2" Radius Corners		No. of 1-1/2" Dia. Faucet Holes	Ship. Wt. Lbs.
	L	W		
GPF95 (Single Bowl, R)*	24-3/8	20-5/8	3 or 4**	10
GPF96 (Single Bowl, L)*	24-3/8	20-5/8	3 or 4**	10
GPF97 (Double Bowl)	32-3/8	20-5/8	3 or 4**	12-1/2

Note: Drain opening size is 3-1/2".
Above models are fully sound deadened.
*Suffix "L" or "R" means drain outlet is located in upper left or right corner of sink compartment.
**All have four holes, but one hole has a removable plug.

Spacemaker Built-In 18" Dishwasher

GE	
GSS1800Z	
Features	
Wash System	
Wash levels	2
Cycles	4
Pots & Pans	Dial
Normal Wash	Dial
Light Wash	Dial
Rinse Only/Hold	Dial
Options	7
Heated Dry	Rocker
Racks, shelf & basket (upper/lower)	Standard
Silverware basket	Standard
Control type	Turn-to-start
Cycle progress indicators	Dial
Rinse Aid dispenser	●
120°F @ inlet water capability	●
Leveling screws	●
Economical/Quiet	
Sound Insulation Package	Standard
Appearance	
Colors available	White/Almond/Black
Color panels	Black/Harvest, Almond/White
Door & Access (2 Reversible)	
Weights & Dimensions	
Approx. shipping wt. (lbs.)	70
Height w/legs retracted (in.)	34-1/8
Overall width / Overall depth (in.)	18 / 25-3/8

Note: For trim kit to install wood panel up to 3/16" thick on GSS1800Z model only, order Pub. No. 5-A007.

GE Specifications

GE SmartWater™ Filtration Systems

GE		
	GNSV30CWW GNSV30CCC GNSV25CBL	GNSL05C
Features		
SmartWater™ Faucet	Electronic Monitor	Electronic Monitor
Faucet color	White on white Bisque Chrome w/black	Chrome w/black
Feed water pressure (psi)	40 min-125 max.	40 min-125 max.
Feed water temperature	40-100°F	40-100°F
Filtered water flow (gpm)	0.6	0.6
Filter I	Filter Set-FXSVC	Filter Set-FXSVC
Filter cartridge	Block Act. Carbon	Polyspun Depth Filter
Filter II	Filter Set-FXSVC (VOC)	Filter Set-FXSVC
Filter cartridge	Gran. Act. Carbon	Block Act. Carbon
Particulate removal	0.5-1 micron	0.5-1 micron
Chlorine reduction (percent / gals.)	97/600	97/600
Filter life	6 months	6 months
Lead reduction (percent / gals.)	98/600	98/600
Cyst reduction (percent)	99.99	99.99
Turbidity reduction (percent)	99	99
Lindane reduction (percent / gals.) (A Pesticide)	●	91/600
Asbestos reduction (percent)	99	99
Mercury reduction (percent / gals.)	90/600	90/600
Atrazine reduction (percent / gals.)	●	89/600
Filter change indicator	Electronic	Electronic
Installation kit	●	●
Fittings	●	●
Optional basement installation (hardware not included)	●	●
Appearance		
Style	Bracket	Bracket
Unit color	White	White
Filter housing	White	White
Weights & Dimensions		
Approximate shipping wt. (lbs.)	7	7
Overall (WxHxD in inches)	12 x 13 x 4-5/8	12 x 13 x 4-5/8
Power/Ratings		
Faucet monitor power requirement	2 AA batteries (incl.)	2 AA batteries (incl.)
Accessories (available at additional cost)		
Icemaker connection kit	UCKIT	UCKIT
Replacement filter	FXSVC (dual pack)	FXSLC (dual pack)

Caution: Do not use with water that is microbiologically unsafe or of unknown quality, without adequate disinfection before or after the system. Systems certified for cyst reduction may be used on disinfected water that may contain filterable cysts.

GE SmartWater Softening System

GE	
GXSF27E	
Capacity	
Capacity (grains)	27,100*
Features	
Efficiency (grains per lb.-salt)	5060**
Max. hardness removal (gpg)	95
Max. clear water iron reduction (ppm)	4
Resin filter type	Std. mesh
Resin quantity (cu. ft.)	0.72
Resin tank size (in inches)	8 x 40
Salt capacity (lbs.)	200
Regeneration time (min.)	Approx. 118
Service flow rate (at 15 psi drop)	8
Installation pack	●
Electronic controls	●
Permanent settings memory	●
Valve size	3/4"
Plumbing connection	Up to 1"
Appearance	
Style	Sculpted
Unit color	Light Grey
Electronic-demand driven	●
Weights & Dimensions	
Approximate shipping wt. (lbs.)	80
Overall (WxHxD in inches)	51 x 20 x 20
Power/Ratings	
Electronic rating	24V, 60Hz

*GXSF27E-Test protocol @ 11.5 lbs. of salt.
**GXSF27E-Test protocol @ 2.2 lbs. of salt.
Important: All units must be installed according to local codes.
Note: Before installing, see installation instructions packed with product for complete details, or call GE QuickSpecs 800-432-3729.

Vertical Packaged Terminal Air Conditioning

GE Profile™						
Features	Electric Resistance Heat			Heat Pumps		
	AZ75E09DAC	AZ75E12DAC	AZ75E18DAC	AZ75H09DAC	AZ75H12DAC	AZ75H18DAC
BTUH	9,500/9,300	11,700/11,500	17,500/17,200	9,500/9,300	11,700/11,500	17,500/17,200
Voltage	230/208	230/208	230/208	230/208	230/208	230/208
E.E.R. (BTUH/Watt)	10.5/10.5	10.7/10.7	10.0/10.0	10.5/10.5	10.7/10.7	10.0/10.0
Universal heater (kW)	2.55/3.45/5.0	2.55/3.45/5.0	2.55/3.45/5.0	2.55/3.45/5.0	2.55/3.45/5.0	2.55/3.45/5.0
Dehumidification (pints/hr.)	2.7	3.6	5.0	2.7	3.6	5.0
Heating cap (BTUH)				8,400/8,200	10,900/10,700	15,700/15,500
COP @ 47°				3.6	3.3/3.3	3.1
Indoor CFM (Hi/Lo)	310/260	375/315	550/475	310/260	375/315	550/475
Case Dimensions						
Height (in inches)	32-1/4	32-1/4	32-1/4	32-1/4	32-1/4	32-1/4
Width (in inches)	23-1/8	23-1/8	23-1/8	23-1/8	23-1/8	23-1/8
Depth (in inches)	23-1/8	23-1/8	23-1/8	23-1/8	23-1/8	23-1/8
Net wt. (lbs.)	141	154	163	141	154	163
Approx. shipping wt. (lbs.)	152	165	174	152	165	174

Premium Line: 5500 Series and Vertical 7500 Series

Power Connection Kits are REQUIRED on Premium Zoneline Chassis. (See chart.)

The correct kit for the installation is determined by the voltage and amperage of the electrical circuit and the means of connecting the unit to the building wiring. If the unit is to be plugged into a receptacle, a line cord kit would be used; if the unit is to be permanently connected, a permanent connection kit would be used.

Note: 265-volt cord set units must be installed in compliance with National Electrical Code.*

230/208 Volt—Line Cord Connected Units

Power Connection Kit	RAK3152	RAK3202	RAK3302
Heater KW	2.55/2.09	3.45/2.82	5.00/4.09
Watts	2,550/2,090	3,450/2,820	5,000/4,090
BTUH	8,600/7,100	11,700/9,600	17,000/13,900
Amps	11.1/10.0	15.0/13.6	21.7/19.7
Min. Circuit Amps	15	20	30
Recommended Protective Device	15-Amp Time Delay Fuse or Breaker	20-Amp Time Delay Fuse or Breaker	30-Amp Time Delay Fuse or Breaker

Zoneline Packaged Terminal Unit Specifications

	GE											
	Deluxe Series—Cooling and Electric Heat				Deluxe Series—Heat Pump Units				Premium Series—Heat Pump Units			
	2500 Series Units				3500 Series Units				5500 Series Units			
230/208V Models	AZ25E07D	AZ25E09D	AZ25E12D	AZ25E15D	AZ35H07D	AZ35H09D	AZ35H12D	AZ35H15D	AZ55H07D	AZ55H09D	AZ55H12D	AZ55H15D
Capacity												
Cooling BTUH	7,100/6,900	9,000/8,800	11,700/11,500	14,600/14,300	7,100/6,900	9,000/8,800	11,700/11,500	14,600/14,300	7,100/6,800	9,000/8,800	11,800/11,600	14,700/14,400
EER (BTU/Watt)	11.8/11.8	11.5/11.5	10.9/10.9	9.6/9.6	11.8/11.8	11.5/11.5	10.9/10.9	9.6/9.6	12.0/12.0	11.5/11.5	10.9/10.9	10.0/10.0
Dehumidification pints/hr.	1.7	2.7	3.6	4.5	1.7	2.7	3.6	4.5	1.7	2.8	3.6	4.8
Features												
CFM, Indoor Fan High	240	260	270	310	250	260	280	310	240	290	330	350
CFM, Indoor Fan Low	210	230	240	280	220	230	250	280	220	270	310	330
Vent CFM	40/35	65/60	70/65	70/65	40/35	65/60	70/65	70/65	40/35	65/60	70/65	70/65
Power/Ratings												
Power Factor	95	96	97	94	95	96	97	94	95	96	94	95
Sensible Heat Ratio @ 230 Volts	75%	68%	67%	67%	75%	68%	67%	67%	75%	67%	68%	65%
Watts	600/585	785/765	1,075/1,055	1,520/1,490	600/585	785/765	1,075/1,055	1,520/1,490	590/565	785/765	1,085/1,065	1,470/1,440
Amperes, F.L.	2.8/3.0	3.6/3.9	4.9/5.3	7.0/7.5	2.8/3.0	3.6/3.9	4.9/5.3	7.0/7.5	2.7/2.9	3.6/3.9	5.1/5.5	6.7/7.3
Amperes, L.R.	19.0	21.0	33.0	38.0	19.0	21.0	33.0	38.0	19.0	21.0	33.0	38.0
Reverse Cycle Heat BTUH					6,400/6,200	8,400/8,200	10,900/10,700	13,400/13,200	6,400/6,200	8,400/8,200	10,900/10,700	13,400/13,200
COP					3.5/3.5	3.5/3.5	3.3/3.3	3.1/3.1	3.5/3.5	3.5/3.5	3.3/3.3	3.1/3.1
Watts					535/520	705/685	970/950	1,265/1,250	535/520	700/685	970/950	1,265/1,250
Amps					2.4/2.6	3.1/3.4	4.3/4.7	5.8/6.3	2.4/2.6	3.1/3.3	4.3/4.7	5.8/6.3
Wt. (Net/Ship)*	92/108	93/109	101/117	111/127	96/112	99/115	111/127	121/137	101/117	106/122	116/132	123/139
265V Models												
	AZ25E07E	AZ25E09E	AZ25E12E	AZ25E15E	AZ35H07E	AZ35H09E	AZ35H12E	AZ35H15E	AZ55H07E	AZ55H09E	AZ55H12E	AZ55H15E
Capacity												
Cooling BTUH	7,100	9,000	11,700	14,600	7,100	9,000	11,700	14,600	7,100	9,000	11,800	14,700
EER (BTU/Watt)	11.8	11.5	10.9	9.6	11.8	11.5	10.9	9.6	12.0	11.5	10.9	10.0
Dehumidification pints/hr.	1.7	2.7	3.6	4.5	1.7	2.7	3.6	4.5	1.7	2.8	3.6	4.8
Features												
CFM, Indoor Fan High	240	260	270	310	250	260	280	310	240	290	330	350
CFM, Indoor Fan Low	210	230	240	280	220	230	250	280	220	270	310	330
Vent CFM	40	65	70	70	40	65	70	70	40	65	70	70
Power/Ratings												
Power Factor	96	94	94	96	96	94	94	96	96	94	94	96
Sensible Heat Ratio @ 265 Volts	75%	68%	67%	67%	75%	68%	67%	67%	75%	67%	68%	65%
Watts	600	785	1,075	1,520	600	785	1,075	1,520	590	785	1,085	1,470
Amperes, F.L.	2.4	3.2	4.4	6.0	2.4	3.2	4.4	6.0	2.3	3.2	4.5	5.8
Amperes, L.R.	16.0	18.0	24.0	31.0	16.0	18.0	24.0	31.0	16.0	18.0	24.0	31.0
Reverse Cycle Heat BTUH					6,400	8,400	10,900	13,400	6,400	8,400	10,900	13,400
COP					3.5	3.5	3.3	3.1	3.5	3.5	3.3	3.1
Watts					535	700	970	1,265	535	705	970	1,265
Amps					2.2	2.8	3.9	5.0	2.2	2.8	3.9	5.0
Wt. (Net/Ship)*	92/108	93/109	100/117	111/127	96/112	99/115	111/127	121/137	101/117	106/122	116/132	123/139

*ICR adds 3 pounds to unit weight.

Built-In “J” Series Units and Heat Pumps

GE										
Models	Chassis/Cool Regular Mount						Chassis/Cool High Mount			Chassis/Heat/Cool Regular Mount
	AJCS06LCA	AJCS08ACA	AJCS10ACA	AJCS09DCA	AJCS10DCA	AJCS12DCA	AJCH10ACA	AJCH10DCA	AJCH12DCA	AJES12DCA
Capacity										
BTUH-AHAM	6,000	8,000	9,900	8,900/8,700	9,900/9,700	11,600/11,400	9,900	9,900/9,700	11,600/11,400	11,600/11,400
E.E.R.	9.5	9.2	9.2	9.5/9.5	9.2/9.2	9.0/9.0	9.2	9.2/9.2	9.0/9.0	9.0/9.0
Dehumidification (pints/hr.)	1.4	2.0	2.7	2.5	2.6	3.2	2.7	2.6	3.2	3.2
Features										
Fan speeds (cool/fan only)	2/2	2/2	2/2	2/2	2/2	2/2	2/2	2/2	2/2	2/2
Fan only speeds										2
Airflow (cfm) roomside hi/low	210/180	250/210	250/210	250/210	250/210	265/230	250/210	250/210	265/230	265/230
Air exchange exhaust	•	•	•	•	•	•	•	•	•	•
Variable setting thermostat	•	•	•	•	•	•	•	•	•	•
Filter type	Slide-Out	Slide-Out	Slide-Out	Slide-Out	Slide-Out	Slide-Out	Slide-Out	Slide-Out	Slide-Out	Slide-Out
Rotary compressor	•	•	•	•	•	•	•	•	•	•
Economical/Quiet										
Fan cycle switch	•	•	•	•	•	•	•	•	•	•
Appearance										
Slide-out chassis	•	•	•	•	•	•	•	•	•	•
Installation	Wall	Wall	Wall	Wall	Wall	Wall	Wall	Wall	Wall	Wall
Window installation kit										Optional
Wall case required	RAB46/47/48	RAB46/47/48	RAB46/47/48	RAB46/47/48	RAB46/47/48	RAB46/47/48	RAB46/47/48	RAB46/47/48	RAB46/47/48	RAB46/47/48
Weights & Dimensions										
Height (in inches)	←-----→ 15-5/8						←-----→			
Width (in inches)	←-----→ 26						←-----→			
Depth (in inches)	←-----→ 16-7/8						←-----→			
Approx. net wt. (lbs.)	62	67	75	69	76	79	75	76	79	80
Approx. shipping wt. (lbs.)	70	75	83	77	84	87	83	84	87	88
Power/Ratings										
Voltage	115	115	115	230/208	230/208	230/208	115	230/208	230/208	230/208
Amps-AHAM	5.7	7.9	9.7	4.2/4.6	4.9/5.3	5.8/5.3	9.7	4.9/5.3	5.8/6.3	5.8/6.3
Watts input	630	870	1,075	935/915	1,075/1,055	1,290/1,265	1,075	1,075/1,055	1,290/1,265	1,290/1,265
Line cord plug	Parallel	Parallel	Parallel	Tandem	Tandem	Tandem	Parallel	Tandem	Tandem	Perpendicular
Recommended circuit protection (time delay)	15 Amps	15 Amps	15 Amps	15 Amps	15 Amps	15 Amps	15 Amps	15 Amps	15 Amps	20 Amps
Electric Resistance Heating										
BTUH-AHAM										11,600/9,480
Amps (max. connected load)										16.0
Watts output										3,400/2,780

Wall Outlets

All wiring, including installation of receptacle, must be made in accordance with local electrical codes and regulations. Electrical outlet should be in reach of line cord.

Note: Aluminum wiring may pose special problems—consult a qualified electrician.



Parallel
115V.
15 Amp.



Tandem
230/208V.
15 Amp.



Perpendicular
230/208V.
20 Amp.



Large Tandem
230/208V.
30 Amp.

GE has a policy of continuous improvement on its products and reserves the right to change materials and specifications without notice.

GE Warranties

The condensed list below is a convenient overview of the written warranties offered on various GE appliances described in this catalog. For complete warranty details on a specific GE appliance model, contact your nearest GE appliance supplier, or call GE Factory Service, toll-free, 800-GE-CARES (800-432-2737).

Appliance	Length	Type	Warranty Covers	Parts Or Labor	Where Serviced*
Refrigerators (All models, except GMR02BAN, GMR04BAN, GMR06AAM)	1-Year	Full	Entire Appliance	Both	In-Home
	Additional 4-Year (5 years total)	Full	Sealed Refrigeration System, Compressor	Both	In-Home
GMR02BAN, GMR04BAN, GMR06AAM	1-Year	Limited	Entire Appliance	Parts	In-Home**
	Additional 4-Year (5 years total)	Limited	Compressor	Part	In-Home**
Washers	1-Year	Full	Entire Appliance	Both	In-Home
	Additional 4-Year (5 years total)	Limited	Auto Balance Suspension System, ArmorGuard Lid & Cover Protection, Steel Drive Transmission	Parts	In-Home***
	Additional 9-Year (10 years total)	Limited	Outer Tub	Parts	In-Home***
	Additional 19-Year (20 years total)	Limited	PermaTuf II™ Basket	Parts	In-Home***
Dryers (Large Capacity and Spacemaker®)	1-Year	Full	Entire Appliance	Both	In-Home
Dryers (Extra-Large and Super Capacity)	1-Year	Full	Entire Appliance	Both	In-Home
	Additional 4-Year (5 years total)	Limited	Dryer Drum	Parts	In-Home***
Advantium™ Oven	1-Year	Full	Entire Appliance	Both	In-Home
	3-Year	Full	Heating System	Both	In-Home
	Additional 9-Year (10 years total)	Limited	Magnetron Tube	Parts	In-Home*
Cooktop	1-Year	Full	Entire Appliance	Both	In-Home
Electric and Gas Ranges	1-Year	Full	Entire Appliance	Both	In-Home
Hoods	1-Year	Full	Entire Appliance	Both	In-Home
Microwave Ovens JVM1630BB/WB, JVM1631BB/WB/CD, JVM1441BD/WVD, JEM25WY/GY, JE740WY/GY	1-Year	Full	Entire Appliance	Both	In-Home
	Additional 9-Year (10 years total)	Limited	Magnetron Tube	Part	In-Home***
	1-Year	Limited	Entire Appliance	Both	Carry-In**
JE520BW/WC	Additional 9-Year (10 years total)	Limited	Magnetron Tube	Part	Carry-In**
	1-Year	Limited	Entire Appliance	Both	Carry-In**
Dishwashers GSD3200GWW/CC/BB, GSD2200GWW/CC/BB, GSD2000GWW/CC/AA/BB, GSD1900GWH, GSM2100GWW/CC	1-Year	Full	Entire Appliance	Both	In-Home
	Additional 1-Year (2 years total)	Limited	Water Distribution System	Parts	In-Home***
	Additional 9-Year (10 years total)	Full	PermaTuf® Tub and Door Liner	Both	In-Home
Disposers GFC520F, GFC525F, GFC320F, GFC325F, GFC329G	1-Year	Full	Entire Appliance	Both	In-Home*
	Additional 1-Year (2 years total)	Extended/Limited	Entire Appliance	Parts	In-Home*
GE SmartWater™ Filtration Systems	1-Year	Full	Entire Appliance (excludes filters)	Both	In-Home
GE SmartWater Softening Systems	1-Year	Full	Entire Appliance	Both	In-Home
	Additional 2-Year (3 years total)	Limited	Electronic Monitor	Parts	In-Home***
	Additional 9-Year (10 years total)	Limited	Brine Tank, Resin Tank	Parts	In-Home***
Air Conditioners (Vertical and Zoneline®)	1-Year	Full	Entire Appliance	Both	In-Home
	5-Year	Full	Sealed Refrigeration System	Both	In-Home
	Additional 4-Year (5 years total)—Zoneline only	Limited	Fan Motors, Switches, Thermostat, Heater, Heater Protectors, Compressor Overload, Solenoids, Circuit Boards, Auxiliary Controls, Thermistors, Frost Controls, ICR Pump, Capacitors, Varistors and Indoor Blower Bearing	Parts	In-Home*
	Additional 4-Year (5 years total)—Vertical Zoneline only	Limited	Fan Motors, Switches, Heater, Heater Protectors, Compressor Overload, Solenoids, Circuit Boards, Auxiliary Controls, Thermistors, Frost Controls, ICR Pump, Capacitors, Varistors and Indoor Blower Bearing	Parts	In-Home*
Air Conditioners (Built-In Units)	1-Year	Full	Entire Appliance	Both	In-Home
	Additional 4-Year (5 years total)	Full	Sealed Refrigeration System	Both	In-Home

*Except in Alaska. See warranty for details.

**In-Home service available at extra cost.

***Does not include service trip and labor charges.

Instant Dimensional & Installation Information

From the speed of a touchtone phone, order installation information to be delivered through your fax machine.



GE QuickSpecs
1-800-432-3729

This automated fax-on-demand system provides a quick reference to product dimensions for Monogram,® Profile,™ GE® and Hotpoint® appliances.

- **Touchtone Activated**

Simply follow the voice prompts to make your selection from any touchtone phone.

- **Model-Specific Installation Dimensions**

Select accurate installation dimensions by individual model numbers for virtually every model. Make your selection from the List of Available Documents (available by fax from GE QuickSpecs). Select up to 15 documents per call.

- **Feature and Appearances**

Feature information and product illustrations are included for most models.

- **Fax Information to Any Fax Telephone Number**

Once you make your selection, you will be asked to enter the fax telephone number where you wish your request to be faxed (your office, job site, customer). It will be faxed to the specified fax number within 15 minutes.

- **Available 24 Hours a Day, 7 Days a Week**

Top-Freezer Refrigerators	HTS18BCM HTS18BBM	HTS17BCM HTS17BBM	HTR17BBM	HTS16BCM	HTR16BBM	HTS15BCM HTS15BBM	HTH15BBM HTR15BBM	HTR15ABM
Capacity								
Total (cu. ft.)	17.9	16.9	16.9	15.6	15.6	14.6	14.6	14.6
Fresh food (cu. ft.)	12.89	13.05	13.05	11.69	11.69	10.77	10.68/10.77	10.72
Freezer (cu. ft.)	5.03	3.86	3.86	3.86	3.86	3.86	3.86	3.86
Shelf area (sq. ft.)	20.8	16.7/17.5	17.5	16.4	17.2	16.4/17.2	17.2	16.1
Features								
Upfront temperature controls	●	●	●	●	●	●	●	●
Cabinet shelves (adjustable)	2 Wire	2 Wire	2 Wire	2 Wire	2 Wire	2 Wire	2 Wire	2 Wire
Vegetable/fruit crisper(s)	2 Full-Width	2 Full-Width	2 Full-Width	2 Full-Width	2 Full-Width	2 Full-Width	2 Full-Width	2 Full-Width
Fixed door shelves	2	2	2	2	2	2	2	1 Full-Width
Dairy compartment	3 (with gallon storage)	2 tall bottle storage	2 tall bottle storage	2 tall bottle storage	2 tall bottle storage	2 tall bottle storage	2 tall bottle storage	2 tall bottle storage
Interior light system	●	●	●	●	●	●	●	●
Quiet Package—Quiet Design	Single	Single	Single	Single	Single	Single	Single	Single
Automatic moisture control	Deluxe	Deluxe	Deluxe	Deluxe	Deluxe	Deluxe	Deluxe	Deluxe
NeverClean™ condenser	●	●	●	●	●	●	●	●
Freezer Features								
Factory-installed electronic icemaker & bin	● / Opt. (IM4)	● / Opt. (IM4)	Opt. (IM4)	●	Opt. (IM4)	● / Opt. (IM4)	Opt. (IM4)	Opt. (IM4)
Ice 'N Easy trays	- / 2	- / 2	2		2	- / 2	2	1
Ice storage bin	Ice Bucket / -	Ice Bucket / -		Ice Bucket		Ice Bucket / -		
Ice shelf		- / ●	●		●	- / ●	●	
Spill-proof freezer floor	●							
Wire freezer compartment shelves	1 FW (2 pos.)							
Fixed door shelves	2	2	2	2	2	2	2	2
Exterior								
Color(s) available*	WW WW, CC	WW WW, CC	WW, CC	WW	WW, CC	WW WW, CC	WW, CC AA CM	WW, CC
Door handle(s)*	CM	CM	CM Recessed	CM	CM Recessed	CM	CM Recessed	CM Recessed
Customer installed handles	●							
Exterior design	Rounded Doors	Square Doors	Square Doors	Square Doors	Square Doors	Square Doors	Square Doors	Square Doors
Reversible doors	●	●	●	●	●	●	●	●
Choose right or left door opening	●	●	●	●	●	●	●	●
Adjustable rollers	Front	Front	Front	Front	Front	Front	Front	Front
Weights & Dimensions								
Height to top of hinge (in.) A	66-5/8	67-3/8	67-3/8	64-3/4	64-3/4	61-3/4	61-3/4	61-3/4
Height to top of case (in.) B	66-1/8	66-7/8	66-7/8	64-1/4	64-1/4	61-1/4	61-1/4	61-1/4
Case depth without door (in.) C	27-1/2	26-3/4	26-3/4	25-7/8	25-7/8	25-7/8	25-7/8	25-7/8
Case depth less door handle (in.) D	30-1/4	30	30	29-1/8	29-1/8	29-1/8	29-1/8	29-1/8
Case depth with door handle (in.) E	32-1/8	31-7/8	30	31	29-1/8	31	29-1/8	29-1/8
Depth w/fresh food door open 90° (in.) F	58-1/8	55-3/4	55-3/4	54-7/8	54-7/8	54-7/8	54-7/8	54-7/8
Width (in.) G	29-1/2	28	28	28	28	28	28	28
Width w/door open 90° less door handle (in.) H	30	28-5/8	28-5/8	28-5/8	28-5/8	28-5/8	28-5/8	28-5/8
Air clearances Each side (in.)								
Top (in.)	1/8	3/4	3/4	3/4	3/4	3/4	3/4	3/4
Back (in.)	1	1	1	1	1	1	1	1
Approx. shipping wt. (lbs.)	203/198	184/179	183	175	169	171/166	165	163

*Color(s) available: WW = White on white, CC = Bisque on bisque, AA = Almond on almond, CM = Color-Matched.

ALL MODELS AVAILABLE IN U.S. AND CANADA.

Top-Freezer No-Frost Refrigerator

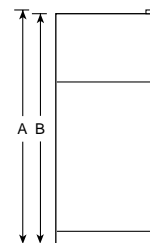

Front View

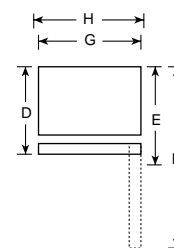

Top View

Note:
All Top-Freezer No-Frost Right-Hand Refrigerator Doors:
 As you face the front of the refrigerator, the handle is on your right and the hinges are on your left.

All Top-Freezer No-Frost Left-Hand Refrigerator Doors:
 As you face the front of the refrigerator, the handle is on your left and the hinges are on your right.



30" electric ranges	RB757BC	RB753BC	RB525BC RB525C
Features			
Oven cleaning	Self-Clean	Self-Clean	Standard
Oven capacity	5.0	5.0	5.0
Oven shelves	2	2	2
Porcelain-enameled upswept cooktop	●	●	●
8-inch heating elements	2	2	1
6-inch heating elements	2	2	3
Plug-in Calrod® heating elements	●	●	●
Removable one-piece drip bowls	Porcelain	Chrome	Chrome
Heating element "ON" indicator lights	●	●	●
Oven cycling light	●	●	●
Broiler pan with grid	●	●	●
Appearance			
Color appearance*	WH/CT	WH/CT	WH/CT WH/AD
Oven window door	●		
Door handle	Designer-Style	Designer-Style	Visor
Lift-off oven door	Black Glass	Black Glass	Black Glass CM*
Full-width storage drawer	●	●	●
Weights & Dimensions			
Overall oven interior dimensions (W x H x D in inches)	← 23-3/4 x 19 x 18-1/2 →		
KW rating @ 240V	11.7	10.2	10.1
208V	8.8	7.7	8.0
Approx. shipping wt. (lbs.)	155	149	150/155

*CT = Bisque, WH = White, AD = Almond, CM = Oven door is color-matched to cooktop and drawer front (either White or Almond).

24" and 20" electric ranges	RA524W	RA520W
Features		
Oven cleaning	Standard	Standard
Oven shelves	2	2
Recessed lift-up cooktop	●	●
Porcelain-enameled subtop	●	●
8-inch heating elements	1 Plug-in	1 Plug-in
6-inch heating elements	3 Plug-in	3 Plug-in
Removable drip bowls	Chrome	Chrome
Push-to-turn controls	●	●
Heating element "ON" indicator lights	2	2
Oven cycling light	●	●
Broiler pan with grid	●	●
Appearance		
Color appearance*	WH	WH/AD
Porcelain-enameled oven door	Solid CM*	Solid CM*
Four leveling legs	●	●
Weights & Dimensions		
Overall oven interior dimensions (W x H x D in inches)	19 x 14 x 19	16 x 15 x 19
KW rating @ 240V	8.2	8.2
208V	6.2	6.2
Approx. shipping wt. (lbs.)	145	120

*WH = White, AD = Almond, CM = Color-Matched.

30" gas ranges	RGB745WEA RGB745BEA	RGB528BEA/ RGB528PEA	RGB524PEA/ RGB524PPA	RGB508PEA/ RGB508PPA
Features				
Extra-large oven	Self-clean	Standard	Standard	Standard
Cooktop burners	Sealed	Twin	Twin	Twin
Porcelain-enameled cooktop	Upswept	Upswept	●	●
Lift-up cooktop		●	●	●
Easy-clean subtop		●	●	●
Valves (degree of turn)	270°	140°	140°	140°
Removable drip pans	Chrome	Opt. Access.	Opt. Access.	Opt. Access.
Removable square grates	Grey Heavy Steel Black Heavy Steel	Black Grey	Black	Black
Ignition system	Electronic	Electronic	Electronic Pilot	Electronic Pilot
Oven shelves	2	2	2	2
Six embossed rack positions	●	●	●	●
Slide-out broiler drawer		●	●	Drop-down door
Appearance				
Color appearance*	WW WH, CT	WH/CT WW	WH/CT WH/CT	WH/CT WH/AD
Frameless oven door	White Glass Black Glass	Black Glass White Porc.-Enam.	Solid CM* Porc.-Enam.	Solid CM* Porc.-Enam.
Handle style	Designer-Style	Visor	Visor	Visor
Weights & Dimensions				
Overall oven interior dimensions (WxHxD in inches)	← 24 x 17 x 19 →			
Approx. shipping wt. (lbs.)	185	165	147	166
Power/Ratings				
Gas range electrical rating†	← 120V, 60 Hz, 5A →			
Top burners** (000's BTU's) NAT/LP	(1)-12.0/9.5 (1)-5.0/3.5 (2)-9.5/7.0	← 9.0/8.0 →		
Oven/broiler burners** (000's BTU's) NAT/LP	16.0/16.0-Oven 13.5/12.0-Broil	← 18.0/16.5 →		
Accessories				
LP conversion kit		●	●	●

*WW = White on white, WH = White, AD = Almond, CT = Bisque, CM = Indicates color of oven door (either White or Almond).
 **Factory set for natural gas. A set of LP orifices is included with each range for LP gas conversion.
 †Electrical rating not applicable to standing pilot models RGB524PPA/RGB508PPA.

24" and 20" gas ranges	RGA524EW/PW	RGA520EW/PW
Features		
Oven cleaning	Standard	Standard
Oven shelves	2	2
Recessed lift-up cooktop	●	●
Porcelain-enameled subtop	●	●
Round grates	●	●
Ignition system	Electronic/Pilot	Electronic/Pilot
Push-to-turn controls	●	●
Broiler pan with grid	●	●
Separate broiler drawer (with tip down door)	●	●
Appearance		
Color appearance*	WH	WH
Porcelain-enameled oven door	Solid CM*	Solid CM*
Removable oven door	●	●
Four leveling legs	●	●
Weights & Dimensions		
Overall oven interior dimensions (WxHxD in inches)	19 x 14 x 19	14-7/8 x 16 x 19-1/2
Approx. shipping wt. (lbs.)	140	124
Power/Ratings		
Gas range electrical rating**	120V, 60 Hz, 5A	120V, 60 Hz, 5A
Burner BTU's: Top (Nat/LP)	9,000/8,000	9,000/8,000
Oven (Nat/LP)	18,000/18,000	18,000/18,000

*WH = White, CM = Color-Matched.
 **Electrical rating not applicable to standing pilot models RGA524PW and RGA520PW.
 Factory set for natural gas.
 Can be converted to LP by a qualified technician.

Counter Saver Plus™ over-the-range microwave oven	RVM1435WD RVM1435BD
Features	
Watts (IEC-705 Test Procedure)	950
Oven cavity (cu. ft.)	1.4
Door/case color	White Black
Power levels	10
Electronic touch controls	●
Interactive display system	●
Electronic scrolling digital display w/Clock and AM/PM Pad	●
Variable Scroll Speed	●
Concurrent programming	●
Display On/Off	●
Time Cook	I & II
Auto Defrost/Time Defrost	●
Popcorn Pad	●
Reheat Pad	●
Express Cook Pads (1-6 minutes)	●
Instant on controls	●
Cooking complete reminder	●
Delay Start	●
Timer On/Off	●
Reminder	●
Child lockout	●
Full-View cooktop lighting	●
Two-speed high-capacity exhaust fan	300 CFM
Easy Mount installation	●
Frequency (MHz)	2450
Watts	1480
Electrical input @ 120V Amps	15
Warranty*	1-Yr. In-Home
Limited four-year magnetron warranty* (5 years total)	●
Dimensions	Cavity 19-5/16 x 9-5/16 x 13-3/16
WxHxD (in inches)	29-7/8 x 15-7/8 x 14-5/16
Approx. shipping wt. (lbs.)	73

*Full One-Year Warranty in-home parts and labor included. Plus additional four-year limited warranty on magnetron tube (parts only). See written warranty for details.

Built-in dishwashers	ENERGY STAR® Contract Only HDA2000GWW HDA2000GCC HDA2000GAA HDA2000GGB		HDA1000GWH
	Features		
ENERGY STAR®	●		
Food disposer	●	●	
Wash levels	2	2	
Cycles/Options	4/9	1/4	
Heavy Wash cycle	Dial		
Normal Wash cycle	Dial	Dial	
Water Saver cycle	Dial		
Rinse Only cycle	Dial		
Heated Dry	Rocker	Rocker	
Hot PreWash option	Dial	Dial	
Control Type	Dial w/Rocker	Dial w/Rocker	
Upper	Standard	Standard	
Rack System Lower	Deluxe	Deluxe	
Silverware basket	Deluxe	Deluxe	
Rinse aid dispenser	●	●	
Steel door	●	●	
Center throw door latch	●	●	
Economical/Quiet			
Sound insulation package	Standard		
QuietPower™ motor	●	●	
Appearance			
Colors available*	WW, CC, AA, BB	WH	
Door	Trimless	Trimless	
Color panels Access	Trimless	Trimless	
Weights & Dimensions			
Approx. shipping wt. (lbs.)	80	80	
Height w/legs retracted (in.)	34	34	
Overall width (in.)	24	24	
Overall depth (in.)	25-3/4	25-3/4	
Accessories			
Requires kit for 1/4" panel capability (w/trim)	GPF325W/C/A/B	GPF325W	
Requires kit for 3/4" panel capability (trimless)	GPF375	GPF375	

*Colors available: WW = White on white, CC = Bisque on bisque, AA = Almond on almond, BB = Black on black, WH = White body, black control panel.

Dishwasher accessories

Side panel for all models:
 Contains one panel and adjustable toe-kick for end cabinet installation of built-in model.
 Does not attach to dishwasher.
 Specify color: GPSSAD—Almond
 GPSSWH—White

Optional dishwasher accessories:
 GPF53—Brackets for under non-wood countertop installation
 GPF95—Stainless sink for Spacemaker® dishwasher—single bowl 21-1/4" x 25" Drain hole on right; elbow and strainer included
 GPF96—Stainless sink for Spacemaker® dishwasher—single bowl 21-1/4" x 25" Drain hole on left; elbow and strainer included
 GPF97—Stainless sink for Spacemaker® dishwasher—double bowl 21-1/4" x 33" elbow and strainer included
 GPF100—Heavy spring kit for custom door panel weighing more than 4 lbs.
 GPF310W/C/A/B—Replacement panels (door and access)
Wood panel capability:
 GPF325W/C/A/B—GE 1/4" panel trim kit (door and access)
 GPF375—GE 3/4" trimless panel trim kit (door and access)

Washers	VBSR3100B	VVSR1070B	VBXR1090B
Features			
Capacity/cubic feet	Super/3.2	Super/3.2	Extra-Large/2.7
Wash/spin speed combination(s)	3 (timer)	1	1
Wash/rinse temperatures	3	3 (timer)	3
Number of wash cycles	10	7	9
Water levels	3	3	3
Cotton			
Extra-heavy soil	●		●
Heavy soil	●	●	●
Normal soil	●	●	●
Light soil	●	●	●
Wrinkle free			
Heavy soil	●		●
Normal soil	●	●	●
Light soil	●	●	●
Extra-light soil			●
Rinse & spin			●
Delicate			
Normal soil	●		
Light soil	●		
Rinse & spin	●		
Knits			
Normal soil		●	
Light soil		●	
FlexCare™ agitator	●	●	●
Bleach dispenser	●		●
Fabric softener dispenser	●		
Tuf Tub™ basket	●	●	●
Sound package	Quiet-by-Design™	Quiet-by-Design	Quiet-by-Design
Front serviceable	●	●	●
Colors available*	WW	WW	WW, CC
Approx. shipping wt. (lbs.)	160	152	152

*Colors available: WW = White on white, CC = Bisque on bisque.

Washer specifications

Electrical rating: 115v, 60 Hz, 10 amps

Circuit requirements:

An individual properly-grounded branch circuit, with a three prong grounding-type receptacle protected by a 15- or 20-amp circuit breaker or time-delay fuse, is required.

Dryers	NBXR463EB	NVL333EB
	NBXR463GB	NVL333GB
Features		
Capacity/cubic feet	Extra-Large/6.0	Extra-Large/5.7
Auto Dry Control	●	●
Number of dry cycles	6	3
Heat selections	4	3 Timer
Cottons		
More/Less dry	●	●
Wrinkle free		
More/Less dry	●	●
Cool down	●	●
Timed dry		
Actual minutes on timer	80	70 (Fluff)
Damp dry	●	
Dewrinkle	●	
Quick fluff	●	
Sound package	Quiet-by-Design	Quiet-by-Design
Front serviceable	●	●
Colors available*	WW	WW, CC
Approx. shipping wt. (lbs.)	160	152

*Colors available: WW = White on white, CC = Bisque on bisque.

Dryer specifications

Exhaust options:

Electric: 4-way via rear, right, left and bottom.

Gas: 3-way via rear, left and bottom. Dryer is shipped exhausted to the rear. Alternate exhausting knockouts are supplied.

Circuit requirements:

Electric: An individual properly-grounded branch circuit protected by a 24-amp circuit breaker or time-delay fuse, is required.

Gas: An individual, properly-grounded branch circuit with a three-prong grounding-type receptacle, protected by a 15- or 20-amp circuit breaker or time-delay fuse, is required. (BTU/HR): 22,000. Factory-equipped for natural gas. Tested for LP gas. LP gas supply requires a conversion kit. Check installation instructions for correct kit and have a qualified gas technician install a conversion kit. See dryer ducting information for proper installation.

Electric dryer rating: 208/240V, 5600W, 60 Hz, 24 Amp

Gas dryer electric rating: 120V, 60 Hz, 16 Amp

Hotpoint Warranty

The condensed list below is a convenient overview of the written warranties offered on various Hotpoint and GE® appliances described in this catalog. For complete warranty details on a specific appliance model, contact your nearest Hotpoint/GE appliance dealer, or call GE Factory Service, toll-free, 800-GE-CARES (800-432-2737).

Appliance	Length	Type	Warranty Covers	Parts Or Labor	Where Serviced*
Refrigerators (All models except, GMR02BAN, GMR04BAN, GMR06AAN)	1-Year	Full	Entire Appliance	Both	In-Home
	Additional 4-Year (5 years total)	Limited	Sealed Refrigeration System, Compressor	Both	In-Home
GMR02BAN, GMR04BAN, GMR06AAN	1-Year	Limited	Entire Appliance	Both	Carry-In**
	Additional 4-Year (5 years total)	Limited	Compressor	Part	Carry-In**
Washers	1-Year	Full	Entire Appliance	Both	In-Home
	Additional 4-Year (5 years total)	Limited	Transmission	Parts	In-Home*
	Additional 19-Year (20 years total)	Limited	Tuf Tub™ Basket	Parts	In-Home*
Dryers	1-Year	Full	Entire Appliance	Both	In-Home
	Additional 4-Year (5 years total)	Limited	Extra-Large Capacity Drum	Parts	In-Home*
Ranges	1-Year	Full	Entire Appliance	Both	In-Home
Over-The-Range Microwave Oven	1-Year	Full	Entire Appliance	Both	In-Home
	Additional 4-Year (5 years total)	Limited	Magnetron Tube	Part	In-Home*
Dishwasher (Models HDA2000GWW/CC/AA/BB)	1-Year	Full	Entire Appliance	Both	In-Home
	Additional 9-Year (10 years total)	Full	Polypropylene Tub and Door Liner	Both	In-Home
Dishwasher (Model HDA1000GWH)	1-Year	Full	Entire Appliance	Both	In-Home

*Does not include service trip and labor charges.

**In-Home service available at additional cost.



GE offers four convenient ways to receive the parts and accessories you need.

Now it's easier than ever to order the replacement parts and accessories for all GE® and Hotpoint® major appliances.



- **Order Online:** It's convenient to order many of our most popular replacement parts and accessories online, any time, day or night at GECustomerNet.com. Sign up for your account online today.
- **By Phone:** Receive personal service when you call 800.851.6200. Place your order from 7 a.m. to 7 p.m. CST.
- **By Fax:** Send your order by fax 24 hours a day to 800.322.0914.
- **From our National Distributor Network:** For local service, visit one of our authorized parts distributors. See your GE Area Sales Manager for details.

GE makes it easy for you to save time and money, with:

- Easy online access to look up and purchase the parts you need 24 hours a day
- Over 50,000 parts in stock
- 9 warehouses nationwide
- FREE shipping and handling (minimum order required)
- Competitive everyday prices with volume discounts (Full details in our Wholesale Parts catalog. Call 800.851.6200 to receive a free copy, or contact your ASM.)
- Convenient payment terms

All parts and accessories are backed by a full or limited GE warranty and a 30-day satisfaction guarantee. See written warranty for details.



GE Appliances

General Electric Company
Louisville, Kentucky 40225
GEAppliances.com

Can't find your parts account?

If you already have an appliance account with GE, your parts account has already been established. Just call 800.851.6200 and the friendly staff in our parts department will be glad to help.

Quick Reference Guide Directory

GE ASM	_____	_____
	Name	Phone
GE Telesales ASM	_____	_____
	Name	Phone
Parts Orders	800.851.6200	_____
		Account #
Appliance Orders	800.523.7277	_____
		Account #
Factory Service	800.GE.CARES	
Local Delivery Co.	_____	_____
	Name	Phone
GE Answer Center®	800.626.2000	
Other	_____	_____