

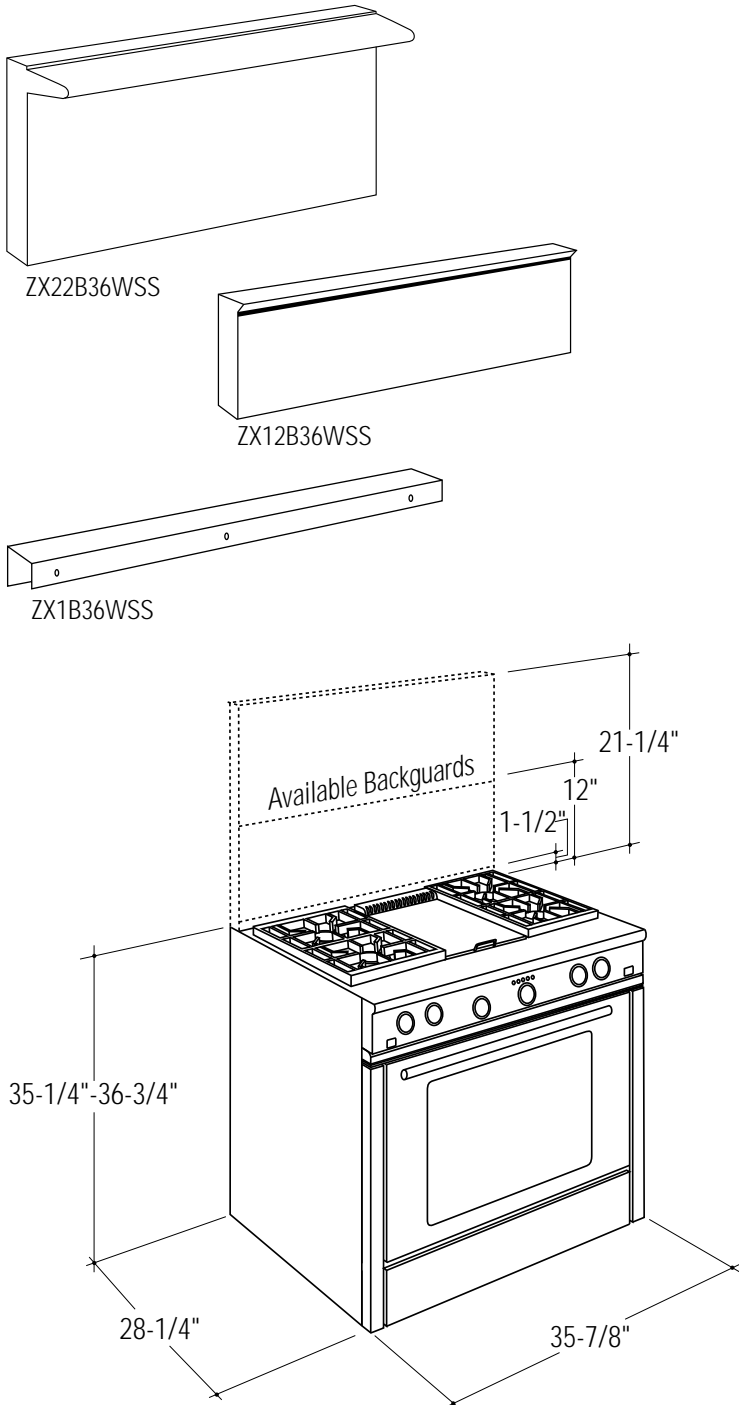

Monogram™

## ZDP36N4DWSS—36" Professional Ranges

### Dimensions and Specifications (in inches)



These ranges are factory set for either natural gas or liquid propane gas.

#### 36" Natural Gas Model:

ZDP36N4DWSS—4 gas burners and griddle

#### 36" Liquid Propane Gas Model:

ZDP36L4DWSS—4 gas burners and griddle

#### Accessory Requirements:

All models **require** the installation of a backguard. A backguard should be ordered at the same time as the range. Both must be on site at the time of installation.

#### Order one backguard for 36" models:

ZX1B36WSS—1-1/2" high backguard (required for island installations)

ZX12B36WSS—12" high backguard

ZX22B36WSS—22" high backguard with warming rack (2 piece)

#### Advance Planning:

Refer to dimensional drawings for appropriate placement and necessary clearances when planning the installation.

- Cabinetry cannot be installed directly above the range.
- This range requires the installation of a vent hood, 30" to 36" above the surface.
  - The vent hood must be at least 24" deep.
  - The vent hood must be the same width as the range.
  - The vent hood must provide at least 600 CFM and up to 800 CFM.
  - When installing a range that includes a grill, select a blower on the high end of the CFM recommendation.
- Working areas adjacent to the range should have 18" minimum clearance between countertop and cabinet bottom.
- Clearance between range and side wall or combustible material must be at least 12" on each side.

For answers to your GE Monogram™, GE Profile™, GE, Hotpoint and RCA appliance questions, call GE Answer Center® service, 800.626.2000.



Listed by  
Underwriters  
Laboratories



Monogram™

## ZDP36N4DWSS—36" Professional Ranges

### Dimensions and Specifications (in inches)

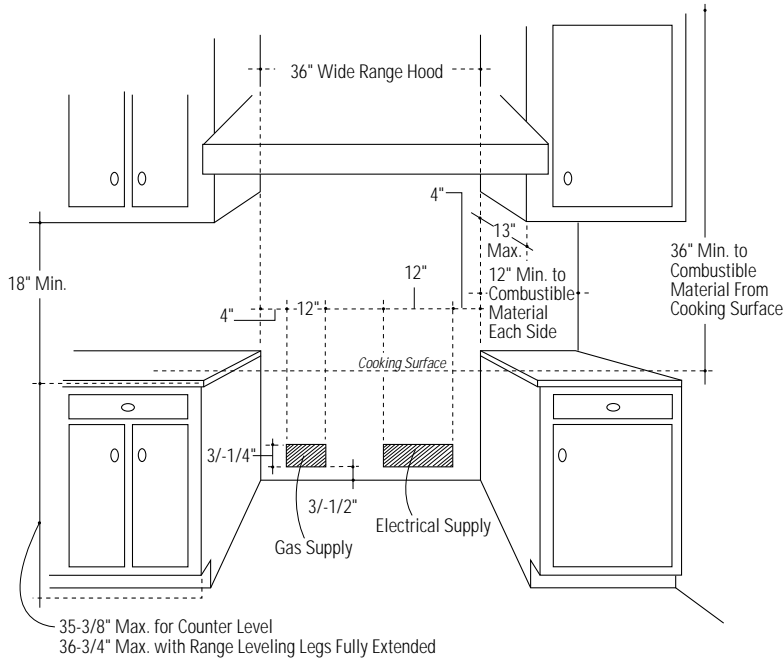

#### If the range is installed in an island:

- Allow 12" min. clearance at the back to combustible materials.
- Allow 36" min. above the cooking surface to combustible materials.
- The vent hood must provide at least 600 CFM and up to 1200 CFM.
- Installation must conform with local codes. In the absence of local codes, the range must comply with the National Fuel Gas Code, ANSI Z223.1-1990.

A.G.A. approved

#### Installation Information:

Before installing, consult installation instructions (Pub. #49-8786) packed with product for current dimensional data.

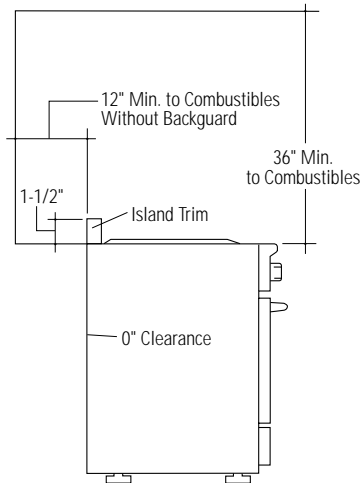
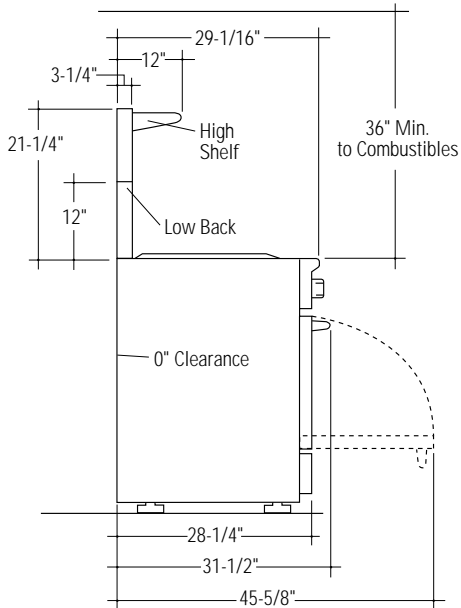

For answers to your GE Monogram™, GE Profile™, GE, Hotpoint and RCA appliance questions, call GE Answer Center® service, 800.626.2000.





Monogram™

## ZDP36N4DWSS—36" Professional Ranges

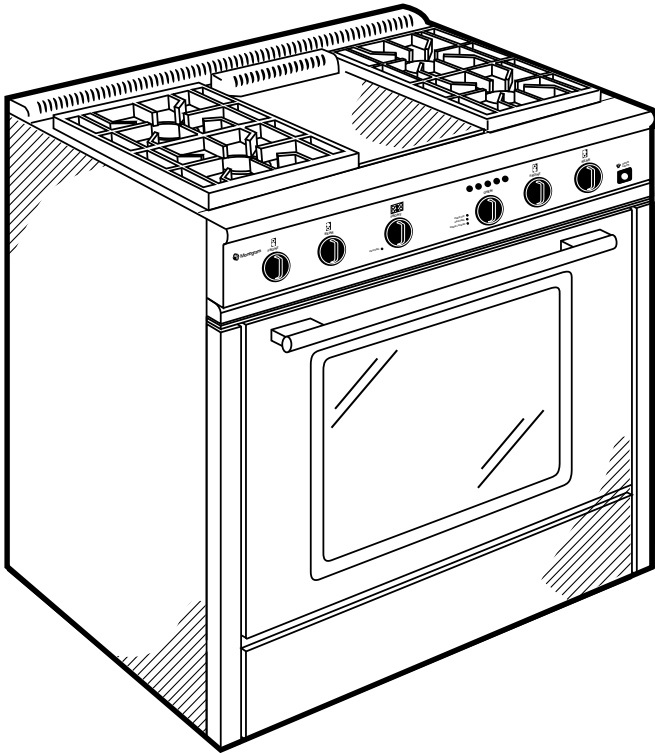

### Features and Benefits

- Stainless Steel Model
- Natural Gas
- Four (15,000/500 BTU) Dual-Ring Gas Burners
- 18,000 BTU Thermostatically-Controlled Griddle
- Cast-Iron, Porcelainized Burner Grates
- Stainless Steel, Slide-Out Drip Tray
- Electronic Ignition with Automatic Re-Ignition
- 4.3 Cubic Foot Capacity Electric Convection Oven
- Self-Cleaning Oven
- Commercial-Style Controls
- 10-Pass Bake Element and 8-Pass Broil Element
- Porcelain-Enameled Broiler Pan with Chrome Plated Grid
- 3 Oven Racks
- Stainless Steel Door with Window
- Tubular Stainless Steel Handle
- Stainless Steel Griddle Cover
- Model ZDP36N4DWSS—Natural Gas
- Model ZDP36L4DWSS—Liquid Propane Gas