

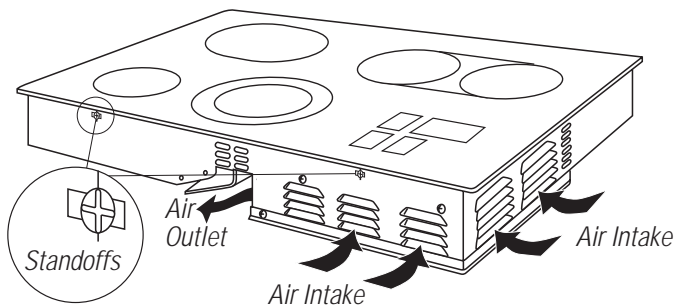

Monogram™

## ZEU304ABG - GE Monogram 30" Digital Electric Cooktop with Ribbon Elements and Bridge Burner

Dimensions and Specifications (in inches)

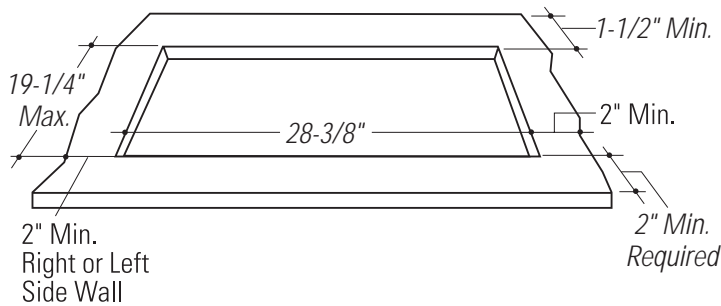
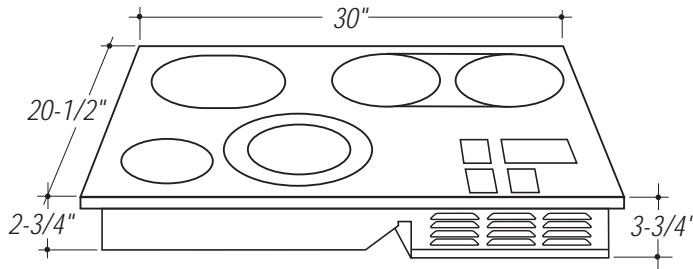

### Cutout Dimensions:

W 28-3/8" max.

L 19-1/4" max.

**Note:** 8.1 KW rating at 240 volts.

6.1 KW rating at 208 volts.

**Note:** Reference installation instructions packed with unit, for complete details.

### Important:

#### Control Housing Air Flow Provision

The control system is fan cooled during usage. Installation into a cabinet must not block the cooling air flow. Review illustrations carefully before cutting the countertop to insure that adequate space for the cooktop and clearances for air space is available.

- Standoffs are positioned along the sides of the cooktop. These standoffs provide a 1/4" air gap between the countertop/cabinet and the cooktop chassis.

#### DO NOT ATTEMPT TO REMOVE THE STANDOFFS

- Maintain 15" min. clearance below cooktop bottom to any horizontal surface such as a full depth cabinet shelf.

For answers to your Monogram®, GE Profile Performance Series™, GE Profile™ or GE appliance questions, call GE Answer Center® service, 800.626.2000.





Monogram™

## ZEU304ABG - GE Monogram 30" Digital Electric Cooktop with Ribbon Elements and Bridge Burner

### Dimensions and Specifications (in inches)

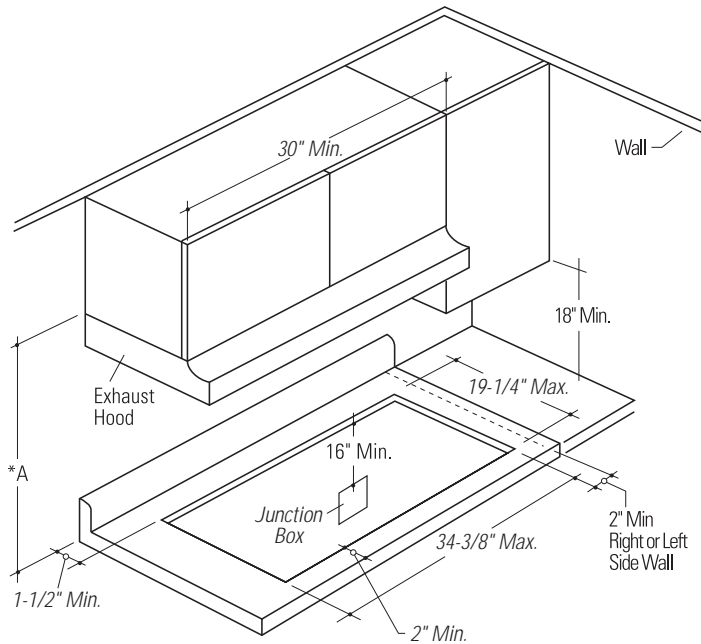

\* A=30 inches minimum clearance between the top of the cooking surface and the bottom of an unprotected wood or metal cabinet or A=24 inches when the bottom of wood or metal is protected by not less than 1/4 inch thick flame-retardant millboard covered with not less than no. 28 MSG sheet steel, 0.015 inch thick stainless steel, 0.024 inch thick aluminum, or 0.020 inch thick copper.

**Caution:** Wall coverings, countertops and cabinets should withstand 200°F heat generated by the cooktop.

We recommend that this cooktop be installed in 42" or larger base cabinets. If the cooktop is installed into a 30" cabinet base, modifications may be required. A 36" cabinet base must allow for installation of hold-down clips and air gaps at sides. The side walls may need to be cut away to provide this space.

- Countertop cutout for this cooktop must be:
  - 28-3/8" wide.
  - 19-1/4" deep.
- Allow clearances:
  - 1-1/2" min. between rear of cutout and rear backsplash or wall.
  - 2" min. from cutout to front edge of countertop.
  - 2" min. from cutout to left and right side adjacent walls.
- Install the junction box within reach of the power cable, at least 16" below the countertop.
- This cooktop is designed to hang from the countertop from its front, back and side flanges.
- Avoid placing cabinetry directly above the cooktop when possible.
- If cabinetry is used above the cooking surface:
  - Use cabinets no more than 13" deep.
  - A 30" wide exhaust hood that projects at least 5" beyond the front of the upper cabinets can also reduce risks.
- Working areas adjacent to the cooktop should have 18" minimum clearance between countertop and cabinet bottom.
- Use this cooktop with any exhaust hood; no special overhead ventilation is required.



*Monogram™*

## ***ZEU304ABG - GE Monogram 30" Digital Electric Cooktop with Ribbon Elements and Bridge Burner***



### ***Features and Benefits***

- *30" Ribbon Digital Electric Cooktop*
- *Black Patterned Tempered Glass Surface*
- *One 6-1/2", One Dual 6"×9", Two 7" Ribbon Heating Elements with Bridge Element*
- *Upfront, Smooth Touchpad Controls*
- *Lock Out Switch*
- *Four Hot Surface Indicator Lights*
- *Digital Power Level Indicator*
- *Model ZEU304BWG - White on white*
- *Model ZEU304ABG - Black on black*