

HOTPOINT®

HSM25GFB – Hotpoint® 25.0 Cu. Ft. Side-by-Side Refrigerator with Dispenser

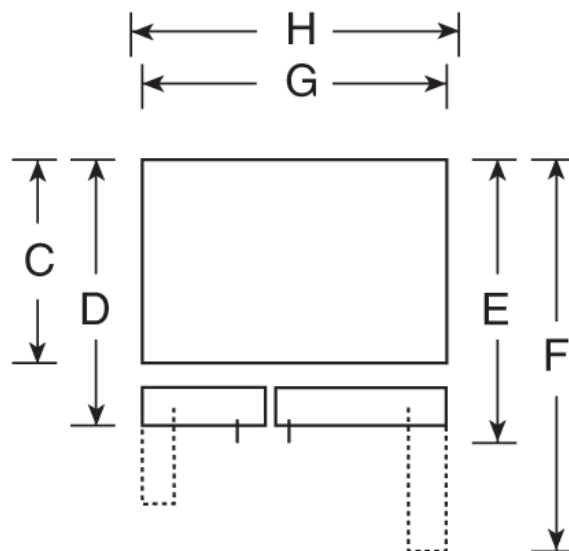

Overall Dimensions	Height to top of hinge (in.) A	69-3/4
	Height to top of case (in.) B	68-3/4
	Case depth without door (in.) C	28
	Case depth less door handle (in.) D	31-1/4
	Case depth with door handle (in.) E	33-9/16
	Depth with fresh food door open 90° (in.) F	49-3/8
	Width (in.) G	35-3/4
	Width with door open 90° inc. door handle (in.) H	38-3/16
Air	Each side (in.)	1/8
	Top (in.)	1
	Back (in.)	1

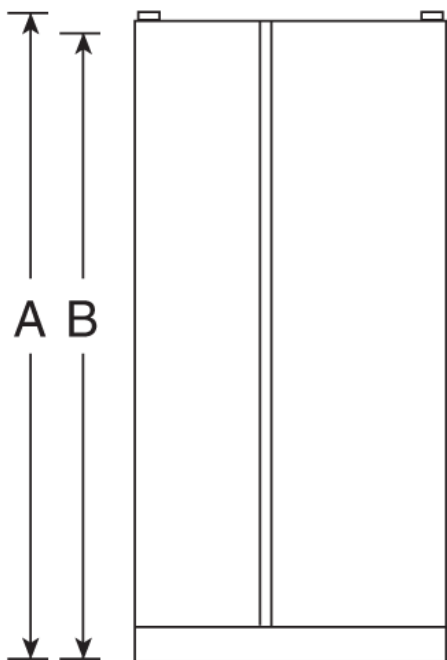

HOTPOINT

HSM25GFB – Hotpoint® 25.0 Cu. Ft. Side-by-Side Refrigerator with Dispenser



Features and Benefits

- Silver metallic exterior - Attractive finish holds magnets and resists fingerprints
- External electronic controls - Know everything that's happening inside without opening the doors
- Tall dispenser with child lock - Easily fills tall containers and offers additional peace of mind
- Adjustable glass shelves - Shelves adjust to handle tall items and create additional space
- Sealed crisper drawers - Keep fruits and vegetables tasting fresh and delicious
- Door bins - Small containers and boxes are easy to find in separate door areas
- Adjustable gallon door bins - Offers ideal space for storing gallon containers in the door
- GE water filtration - six month filter - Removing impurities means fresh-tasting water for your family
- FrostGuard™ technology - Controlled defrosting keeps frozen foods from feeling the burn
- Deluxe quiet design - Significantly reduces unnecessary operating noise in the kitchen
- AutoEnergy saver - Senses door openings and adjusts refrigeration operation cycles accordingly
- NeverClean™ condenser - Sealed compartment keeps coils clean and simplifies maintenance
- Model HSM25GFBSA – Silver Metallic

