

GE Monogram®
36" Built-In Refrigerators

Custom

Options Guide

and

Installation

Instructions

With Custom Panel Dimensions
and Trim Kit
Installation Instructions

These Monogram built-in refrigerators are designed to be customized with decorator door and grille panels. Field installed panels are required.

Factory installed trim will accommodate 1/4" thick custom panels or optional Lexan® and Stainless Steel panel kits.

Optional trim kits allow an even broader range of custom appearance options.

Read this booklet carefully to accomplish the desired appearance and to insure a trouble free installation.

This booklet contains information and illustrations to demonstrate custom possibilities. Custom door and grille panel sizes vary to accommodate the kit being used. Dimensions for each application are included and can be faxed or sent to the cabinet manufacturer so that the panels can be constructed accurately.

Models:

ZIS36N

ZISW36D

ZISB36D

Before you begin - Read these instructions completely and carefully.
 IMPORTANT - Save these instructions for local inspector's use.
 IMPORTANT - OBSERVE ALL GOVERNING CODES AND ORDINANCES.
 Note to Installer - Be sure to leave these instructions with the Consumer.
 Note to Consumer - Keep these instructions with your Use and Care Book for future reference.

⚠ WARNING This appliance must be properly grounded. See "Grounding the Refrigerator," page 15.

⚠ ATTENTION Cet appareil doit être correctement mis à la terre.
 Consulter « Mise à terre du réfrigérateur », page 15.

If you have a question concerning the installation of this product, call the GE Answer Center® Consumer Information Service at 800.626.2000, 24 hours a day, 7 days a week.

If you received a damaged refrigerator, you should immediately contact your dealer or builder.

Proper installation is the responsibility of the installer. Product failure due to improper installation is not covered under the GE Appliance Warranty. See the Use & Care Guide for warranty information.

**For Monogram local service in your area,
 1-800-444-1845.
 For Monogram service in Canada, 1-888-880-3030.
 For Monogram Parts and Accessories, call
 1-800-626-2002.**

⚠ WARNING

- Use this appliance only for its intended purpose.
- Immediately repair or replace electric service cords that have become frayed or damaged.
- Unplug the refrigerator before cleaning or making repairs.
- Repairs should be made by a qualified service technician.

⚠ ATTENTION

- Il ne faut utiliser cet appareil que pour l'usage pour lequel il a été construit.
- Il faut réparer ou remplacer immédiatement tout cordon d'alimentation électrique effiloché ou endommagé.
- Débrancher le réfrigérateur avant le nettoyage ou toute intervention.
- Les réparations doivent être faites par un technicien qualifié.

Contents

Design Information	
Advance Planning for a Flush Installation	3
Cutout and Product Dimensions	3
Installation Between Base & Wall Cabinets	4
Installation At End-of-Run	4
Frameless Cabinets	4
Accessory Panel Kits	4
Advance Planning, Exterior Appearance Options	5
Appearance Examples, Trim Kit Descriptions	5
Custom Panel Dimensions	
ZIS36N	6-9
ZISW36D, ZISB36D	10-13
Side Panel or Filler Options	14
Installation Instructions	15-20
Trim Kits	
ZKH1 Trim Kit Installation Instructions	
Custom Handles with 1/4" Thick Panels	21-25
ZG2 Trim Kit Installation Instructions	
Grille Panel Frame Adjustment	26
ZKT36 Trim Kit Installation Instructions	
3/4" Thick Custom Panels	27-32
ZKHT1 Trim kit Installation Instructions	
Custom Handles with 3/4" Thick Panels	33-37
ZKHSS1 Trim Kit Installation Instructions	
Tubular Stainless Steel Handles for 1/4" Panel Installation	38-41
ZKHTSS1 Trim Kit Installation Instructions	
Tubular Stainless Steel Handles for 3/4" Panel Installation	42-45
ZWCD1 Trim Kit Installation Instructions	
Custom Dispenser Collar	46-47

Advance Planning

Flush or Semi-Flush Enclosure Installations

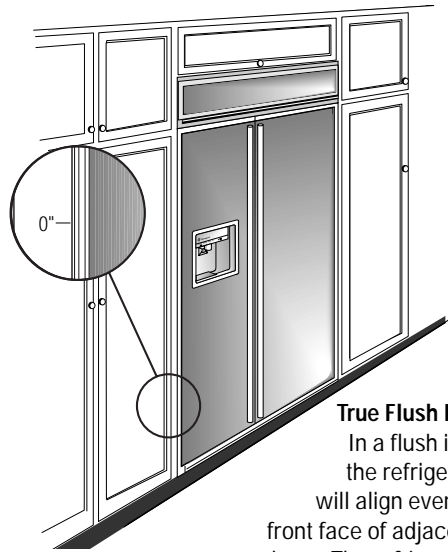

True Flush Installation

In a flush installation, the refrigerator doors will align evenly with the front face of adjacent cabinet doors. The refrigerator blends into the surrounding cabinetry.

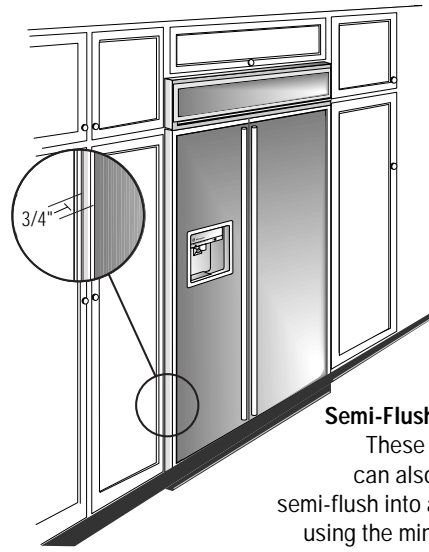

Semi-Flush Installation

These refrigerators can also be installed semi-flush into an enclosure using the minimum cutout width. The case trim creates a frame around the opening.

Monogram built-in refrigerators can be installed flush with typical 24-3/4" deep cabinetry.

When installed semi-flush, the case trim will conceal slight gaps around the enclosure. The refrigerator will project forward approximately 3/4" beyond the front face of surrounding cabinetry.

In any installation situation, a wide range of appearance options can be accomplished through the use of one or more trim kits. See trim kit descriptions and appearance options on page 4.

Side Panel Requirements:

- Side panels are not required whenever the refrigerator is installed into an enclosure or between pantry and oven cabinets.
- Side panels are required whenever the sides of the refrigerator are exposed.
- Side panel sizes vary depending on the type of installation being made.

To accomplish an attractive installation, you must:

1. Determine the need for side panels.
2. Determine side panel thickness.
3. Order matching side panels from the cabinet manufacturer. Be sure to provide the exact dimensions.

Enclosure Cutout and Product Dimensions

- To achieve a flush fit the finished cutout width must be at least 36" wide.
- A semi-flush installation requires 35-1/2" min. finished cutout width.
- The electrical and water locations must be located as shown for either type of installation.

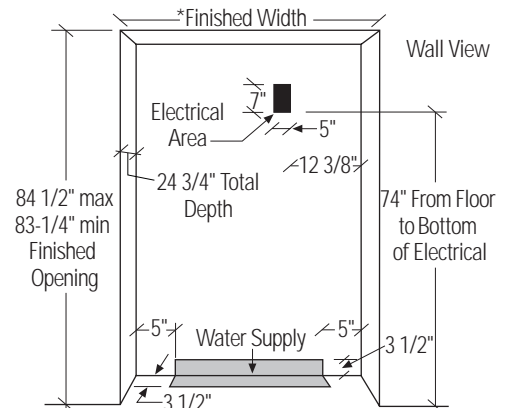
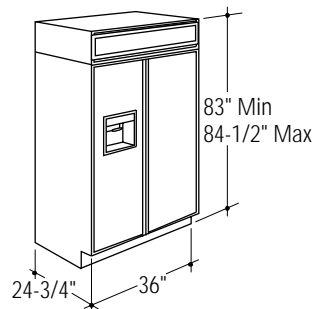

*36" Min. for a flush installation

35-1/2" Min. for a semi-flush installation

Note: Additional cutout width may be required when side panels are used. Add side panel thickness to the finished cutout to calculate rough-in width. See installation examples on the following page.

Design Information

36" Built-In Refrigerators

Installation Examples

Side panels are required whenever the sides of the refrigerator will be exposed.

1/2" to 3/4" side panels are normally set into place and fastened to adjacent cabinetry or to the back wall before rolling the refrigerator into the opening.

Therefore, the rough-in dimensions must allow for side panel thickness. In both a flush and semi-flush installation, the finished dimension, (the width of the opening after side panels are installed), must accommodate the full width of the refrigerator.

See page 14 for side panel sizes.

Installation Between Base & Wall Cabinets

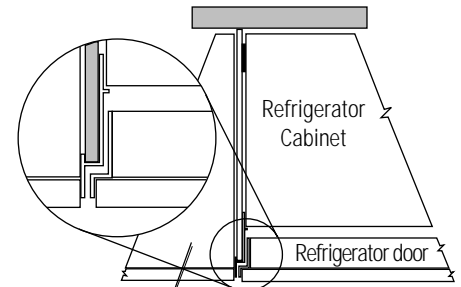
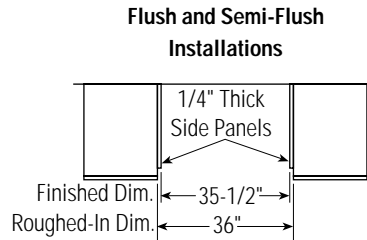
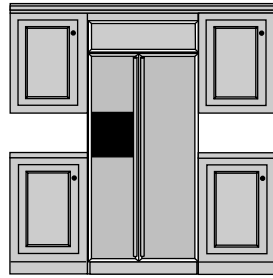

1/4" Side Panels. Insert end of side panel into trim

Note: 1/4" thick side panels can be inserted into the case trim, making the rough-in the same as the outside trim width, 36".

Installation At End-of-Run

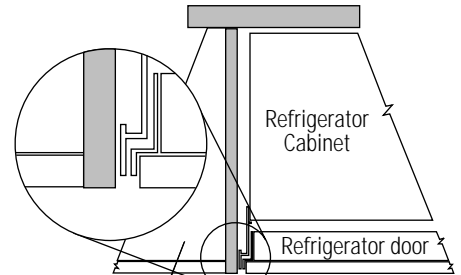
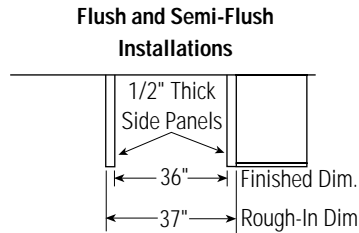
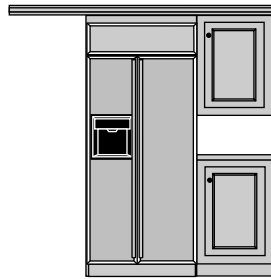

1/2" To 3/4" Side Panels. Leading Edge Flush With Cabinet

Note: 1/2" thick side panels shown. Side panels can be any thickness. Add side panel thickness to outside trim width (36") to calculate the rough-in dimension. The leading (front) edge must be finished to match surrounding cabinetry.

Frameless Cabinets

Side panels, 1/2" minimum thickness are required when using frameless cabinets. The side panel acts as a spacer between the cabinet and the case trim and prevents interference with cabinet door swing. The leading (front) edge must be finished to match surrounding cabinetry.

1/2" To 3/4" Side Panels. Leading Edge Flush With Cabinet

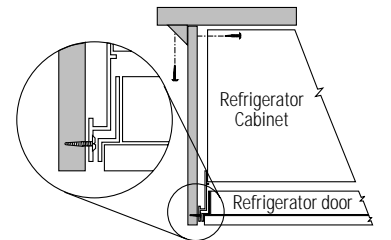

Accessory Panel Kits

Field installed door and grille panels are required. The factory installed trim will accept accessory panel kits. White or black Lexan® and stainless steel kits are available. Panels are cut to size and ready to install. These panel kits must be ordered separately.

A wide range of custom appearance options can be created with optional custom trim kits. See the opposite page for examples and trim kit descriptions.

Model	Black	White	Stainless
ZIS36N	ZWBP36	ZWWP36	ZWSP36
ZISW36D		ZWWP36D	ZWSP36D
ZISB36D	ZWBP36D		ZWSP36D

Advance planning exterior appearance options

These refrigerators are designed to be customized with decorator door and grille panels. Field installed custom door and grille panels are required.

Factory installed trim accommodates 1/4" thick custom panels, Lexan® or stainless steel panel kits.

Appearance options are accomplished through the use of one or more trim kits. Kits must be ordered separately.

Door and grille panel sizes vary to accommodate the kit being used. Sizes are provided in this booklet.

You should:

1. Select the appearance option.
2. Order the trim kit(s) for that option.
3. Order the custom door and grille panels from the cabinet manufacturer. The exact dimension for each trim kit application is provided in this booklet. Find and pull out the page for your application and fax or send it to the cabinet manufacturer. The cabinet manufacturer must have this information to construct the panels accurately.
4. Determine the final installation situation and order matching side panels.

Important: Maximum weight for fresh food panels is 50 pounds and 30 pounds for freezer door panels.

3/4" thick custom panels—Without trim kits

A raised panel design, screwed or glued to a 1/4" thick backing can be used. See pages 7 and 11 for panel sizes and clearances.

Appearance Examples Trim kit Descriptions

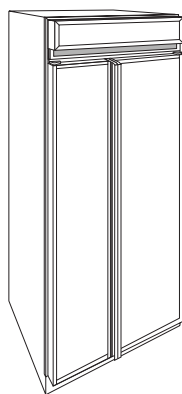

1/4" and 3/4" panels with standard handles. No trim kits required.

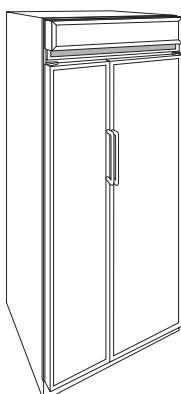

1/4" Custom panels with custom handles. Trim Kit ZKH1.

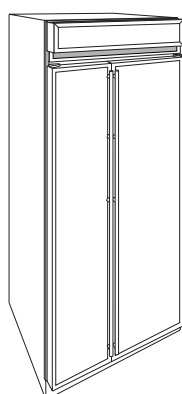

1/4" Custom panels with Tubular Stainless Steel handles. Trim Kit ZKHSS1.

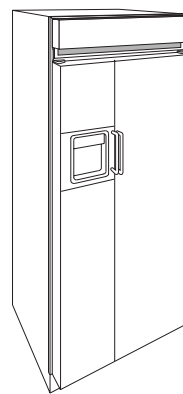

3/4" Custom panels with custom handles. Trim kits ZKT36 & ZKHT1.

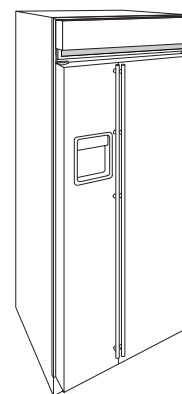

3/4" Custom panels with Tubular Stainless Steel handles and custom dispenser collar. Trim Kits ZKHTSS1, ZKT36 & ZWCD1.

Door Handle Options

ZKH1 – Provides the necessary framework to install custom handles, *of your choice*, onto 1/4" thick panels. (Handles not included.)

ZKHSS1 – Tubular stainless steel handles for 1/4" thick panel installations.

ZKHT1 – Provides the necessary framework to install custom handles, *of your choice*, onto 3/4" thick panels. (Handles not included.) This kit must be used in combination with ZKT36.

ZKHTSS1 – Tubular stainless steel handles for 3/4" thick panel installations. This kit must be used in combination with ZKT36.

Custom Panel Options

ZKT36 – Provides for the installation of 3/4" thick trimless custom door and grille panels with the standard (supplied) full length handle.

Dispenser Options

ZWCD1 – Provides for the installation of a custom collar trim on the dispenser and for one continuous custom panel on the freezer door. This kit can be used alone, or with all other kits.

Toekick Option

ZWT1 – White toekick (supplied toekick is black). Includes a white toekick to fit 36, 42, 48" side-by-side models and 36" bottom mount and single door models.

Grille Panel Options

ZG2 – Provides 1/4" grille panel frame side pieces for 83", 83-1/2" and 84-1/2" installation heights. The supplied grille panel frame is factory set for 84".

Note: ZG1 Grille Panel Kit is available for models produced before January 1997. Panel sizes for ZG1 and ZG2 are the same. The ZG1 kit can be ordered from your Monogram dealer.

Custom Panel Dimensions

36" Built-In Refrigerator

CUSTOM PANEL DIMENSIONS

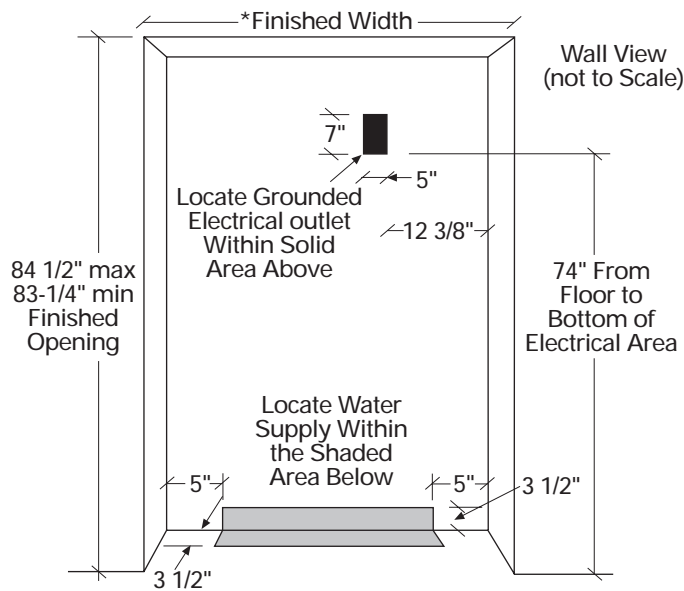
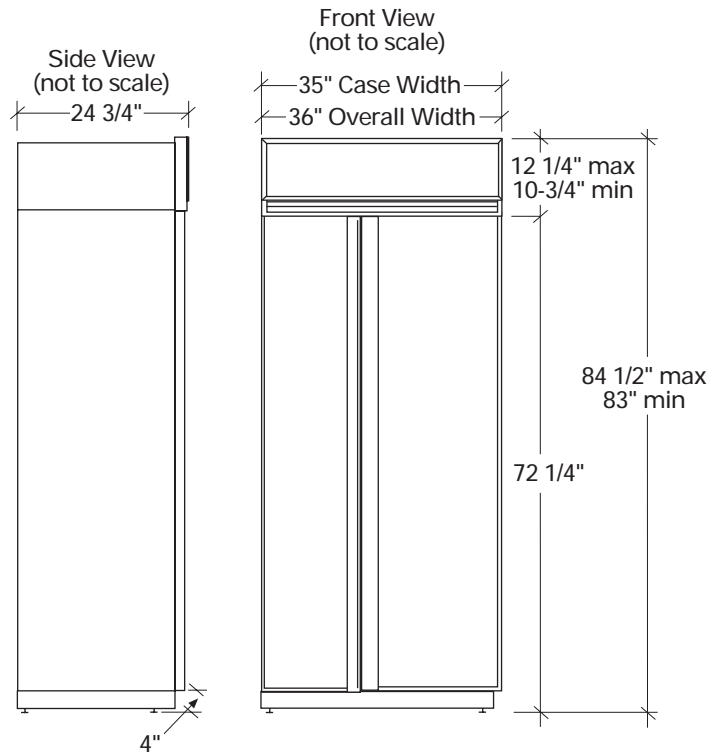

*36" Min. for a flush installation into an enclosure.
 *35-1/2" Min. for a semi-flush installation into an enclosure.
 Note: Additional cutout width may be required when side panels are used. Add side panel thickness to the finished cutout to calculate rough-in width. See installation examples on page 4.

ZIS36N (Non-dispenser)

Design Information

Cutout dimensions, clearances and side panel sizes are determined by the many installation options available. Side panels must be used whenever the sides of the refrigerator will be exposed. Side panels are not required when refrigerator is installed into an enclosure or between pantry and oven cabinets. **IMPORTANT**—Side panels, 1/2" minimum thickness, are required when using FRAMELESS CABINETS.

- Field installed custom panels, Lexan® or stainless steel panels are required. The door panels and grille panel sizes vary to accommodate the kit being used.
- A custom toekick can be installed to match or complement the surrounding cabinetry. Use the supplied toekick as a template to cut out notches around hinges and water lines.

Optional Kits:

- ZWBP36: Black Lexan® Panel Kit (no trim kit required).
- ZWWP36: White Lexan® Panel Kit (no trim kit required).
- ZWSP36: Stainless Steel Panel Kit (no trim kit required).
- ZKH1: For installation of a custom handle on 1/4" panels.
- ZKT36: For installation of 3/4" custom panels.
- ZKHT1: For installation of a custom handle on 3/4" panels. (This kit must be used in combination with ZKT36.)
- ZKHSS1: Tubular Stainless Steel handles on 1/4" panels.
- ZKHTSS1: Tubular Stainless Steel handles on 3/4" panels. (This kit must be used in combination with ZKT36.)
- ZG2: 1/4" grille panel frame side pieces for 83", 83-1/2" and 84-1/2" installation heights. Factory set height is 84".
- ZWT1: White toekick (supplied toekick is black). Includes a white toekick to fit 36, 42, 48" side-by-side models and 36" bottom mount and single door models.

Additional Specifications

- A 115 volt 60 Hz., 15 or 20 amp power supply is required. An individual properly grounded branch circuit or circuit breaker is recommended. Install a properly grounded 3-prong electrical receptacle recessed into the back wall. Electrical must be located on rear wall.
- Water line can enter opening through the floor or back wall. The water line should be 1/4" O.D. copper tubing between the cold water line and water connection location, long enough to extend to the front of the refrigerator. Installation of an easily accessible shut off valve in the water line is recommended.

Clearances

- If the refrigerator is to be installed in a corner:
- A 4" min. clearance between the case trim and adjacent wall on both sides of the refrigerator will assure a 90° door opening and access to all drawers. A 10" clearance is required on both sides for removal of pans.

Custom Panel Dimensions

36" Built-In Refrigerator

CUSTOM PANEL DIMENSIONS

Custom Door Panel Dimensions Using Standard Trim 1/4" thick panels or Panels secured to 1/4" thick backing

ZIS36N (non-dispenser)

Standard Trim with 1/4" Panels

- 1/4" Panels: Cut panels to size.
- Custom handles with 1/4" door panels require Trim Kit ZKH1 (or ZKHSS1 for tubular-stainless steel handles).

Standard Trim with Panels secured to 1/4" thick backing

- Applying a raised panel design to a 1/4" thick backing (screwed or glued): Cut 1/4" panels to size, fabricate the raised panel to permit clearances of at least 2" from the handle side for fingertip clearance of the standard handle, 1-1/4" from the hinge side to avoid striking adjacent cabinetry and 5/16" from the top and bottom edges to allow for the trim flange then install.
- Countertops adjacent to refrigerator installation should be mitered 45° degrees.

Note: ZKHT1 custom handle kit **cannot be used** in this configuration.

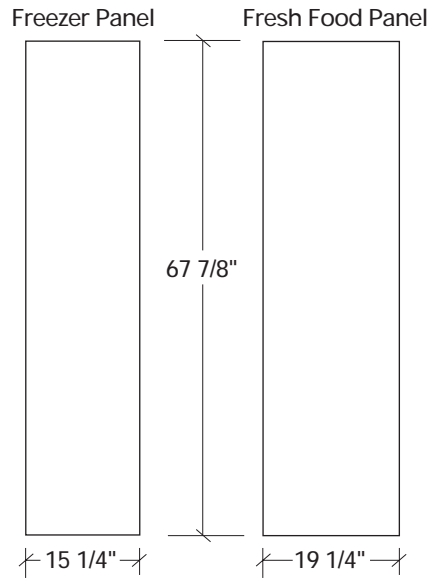

Important: Maximum weight for fresh food panels is 50 pounds and 30 pounds for freezer door panels.

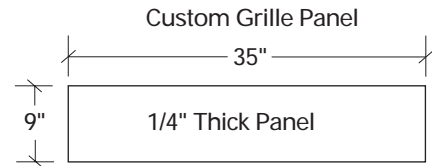

The grille panel frame is factory assembled for 84" installation height. If installation height varies, order ZG2 trim kit which provides optional side trim pieces. Cut grille panel to sizes shown below.

Installation Height	Panel Height
83"	8"
83-1/2"	8-1/2"
84-1/2"	9-1/2"

Important: Maintain 1-1/2" min. gap between top of doors and bottom of panel frame.

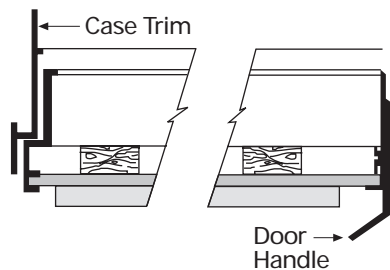
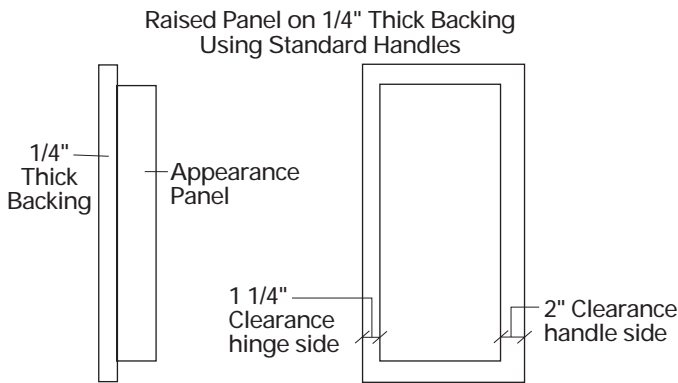

Custom Panel Dimensions

36" Built-In Refrigerator

CUSTOM PANEL DIMENSIONS

Custom Door Panel Dimensions Using Trim Kit ZKT36 3/4" thick panel with standard handle

ZIS36N (non-dispenser)

- The ZKT36 trim kit provides for the installation of 3/4" custom door and grille panels, using the standard full-length handle. Cut panels to size and install.

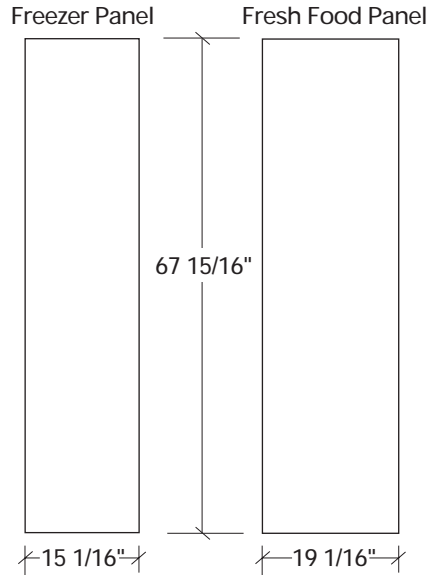

Important: Maximum weight for fresh food panels is 50 pounds and 30 pounds for freezer door panels.

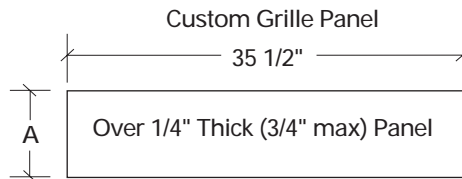

Grille Panel height can vary to fill installation height.

Installation Height	Dimension A
83"	8-1/4"
83-1/2"	8-3/4"
84"	9-1/4"
84-1/2"	9-3/4"

Important: Maintain 1-1/2" min. gap between top of doors and bottom of grille panel.

Custom Panel Dimensions

36" Built-In Refrigerator

Custom Door Panel Dimensions Using Trim Kits ZKT36 3/4" thick panel with custom handle

ZIS36N (non-dispenser)

- ZKT36 and ZKHT1 installed together provides for the installation of 3/4" custom door and grille panels, using a custom handle, of your choice. Order ZKHTSS1 for tubular stainless-steel handles. Cut panels to size, rout the handle side of the panels as shown below and install.

Important: Maximum weight for fresh food panels is 50 pounds and 30 pounds for freezer door panels.

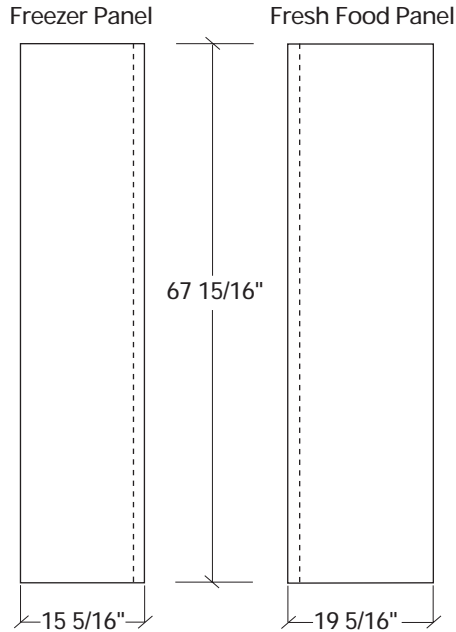

Rout panels to specification below on the handle side of each panel

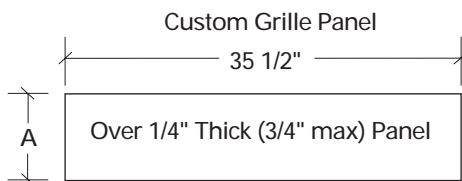
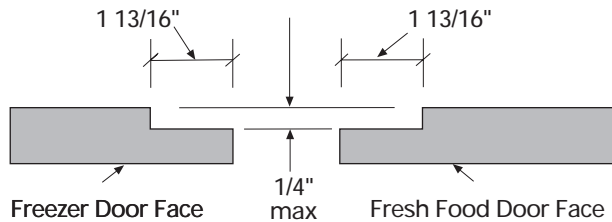

Grille Panel height can vary to fill installation height.

Installation Height	Dimension A
83"	8-1/4"
83-1/2"	8-3/4"
84"	9-1/4"
84-1/2"	9-3/4"

Important: Maintain 1-1/2" min. gap between top of doors and bottom of grille panel.

Custom Panel Dimensions

36" Built-In Refrigerator

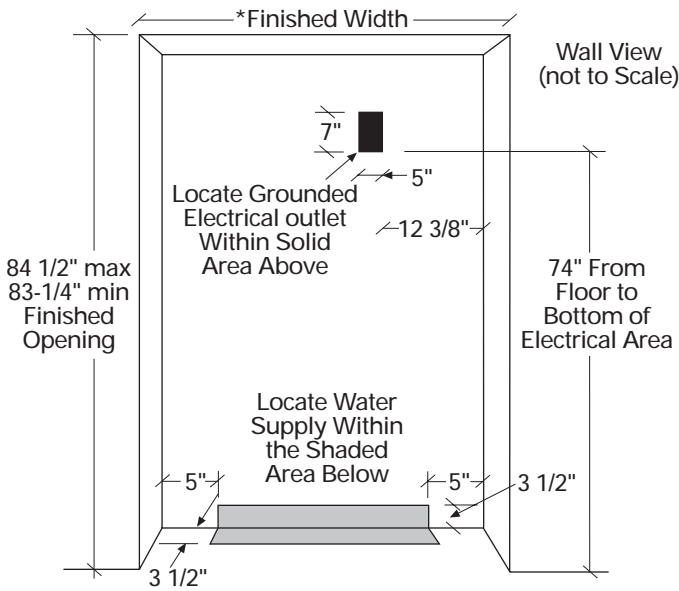
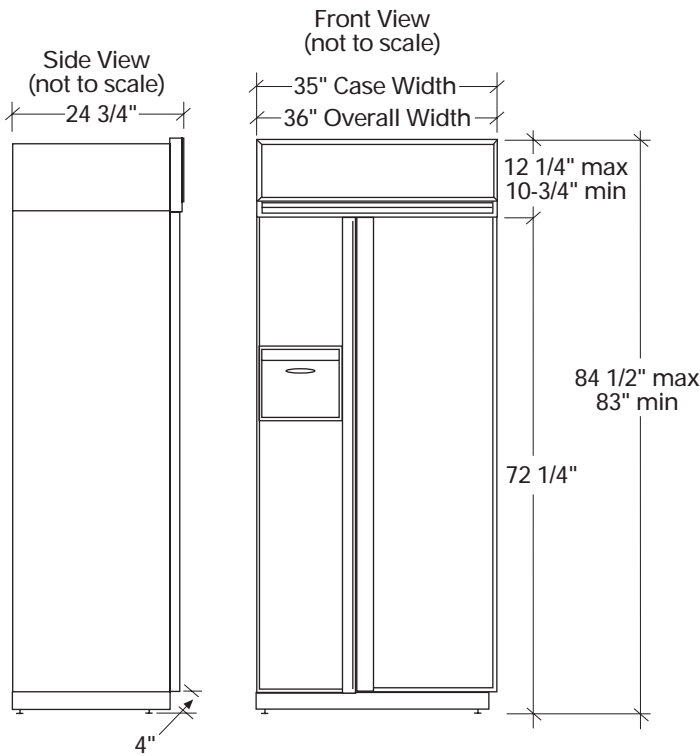

*36" Min. for a flush installation into an enclosure.
 *35-1/2" Min. for a semi-flush installation into an enclosure.
 Note: Additional cutout width may be required when side panels are used. Add side panel thickness to the finished cutout to calculate rough-in width. See installation examples on page 4.

ZISW36D (white dispenser)
 ZISB36D (black dispenser)

Design Information

Cutout dimensions, clearances and side panel sizes are determined by the many installation options available. Side panels must be used whenever the sides of the refrigerator will be exposed. Side panels are not required when refrigerator is installed into an enclosure or between pantry and oven cabinets. **IMPORTANT**—Side panels, 1/2" min. thick, are required for FRAMELESS CABINETS.

- Field installed custom panels, Lexan® or stainless steel panels are required. Custom door panels and grille panel sizes vary to accommodate the kit being used.
- A custom toekick can be installed to match or complement the surrounding cabinetry. Use supplied toekick as a template to cut notches for hinges and water lines.

Optional Kits:

- ZWBP36D: Black Lexan® Panel Kit (no trim kit required).
- ZWWP36D: White Lexan® Panel Kit (no trim kit required).
- ZWSP36D: Stainless Steel Panel Kit (no trim kit required).
- ZKH1: For installation of custom handles on 1/4" panels.
- ZKT36: For installation of 3/4" custom panels.
- ZKHT1: For installation of custom handles on 3/4" panels. (This kit must be used in combination with ZKT36.)
- ZWCD1: For installation of a custom collar trim on the dispenser for one continuous custom panel on the freezer door.
- ZKHSS1: Tubular Stainless Steel handles on 1/4" panels.
- ZKHTSS1: Tubular Stainless Steel handles on 3/4" panels. (This kit must be used in combination with ZKT36.)
- ZG2: 1/4" grille panel frame side pieces for 83", 83-1/2" and 84-1/2" installation heights. Factory set height is 84".
- ZWT1: White toekick (supplied toekick is black). Includes a white toekick to fit 36, 42, 48" side-by-side models and 36" bottom mount and single door models.

Additional Specifications

- A 115 volt 60 Hz., 15 or 20 amp power supply is required. An individual properly grounded branch circuit or circuit breaker is recommended. Install a properly grounded 3-prong electrical receptacle recessed into the back wall. Electrical must be located on rear wall.
- Water line can enter opening through the floor or back wall. The water line should be 1/4" O.D. copper tubing between the cold water line and water connection location, long enough to extend to the front of the refrigerator. Installation of an easily accessible shut off valve in the water line is recommended.

Clearances

If the refrigerator is to be installed in a corner:

- A 4" min. clearance between the case trim and adjacent wall on both sides of the refrigerator will assure a 90° door opening and access to all drawers. A 10" clearance is required on both sides for removal of pans.

CUSTOM PANEL DIMENSIONS

Custom Panel Dimensions

36" Built-In Refrigerator

Custom Door Panel Dimensions Using Standard Trim 1/4" thick panels or Panels secured to 1/4" thick backing

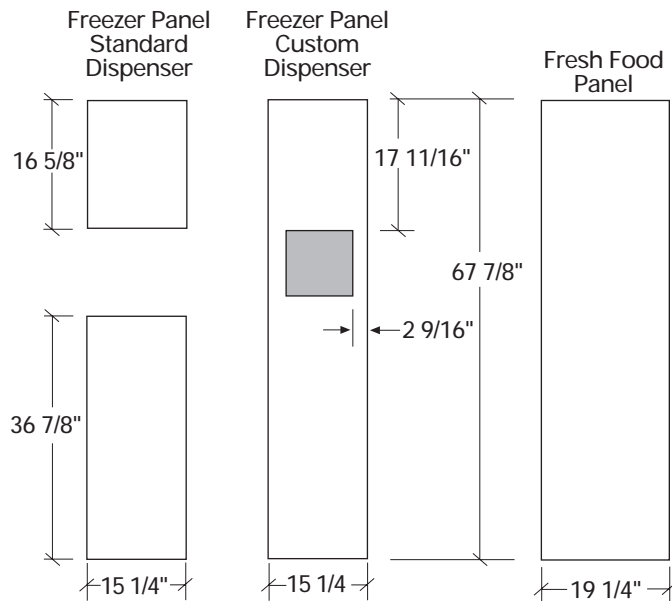

Important: Maximum weight for fresh food panels is 50 pounds and 30 pounds for freezer door panels.

Raised Panel on 1/4" Thick Backing Using Standard Handles

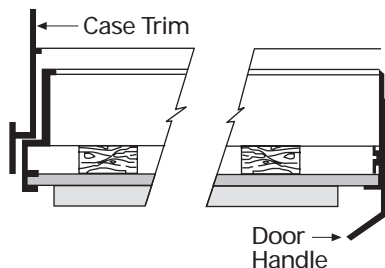
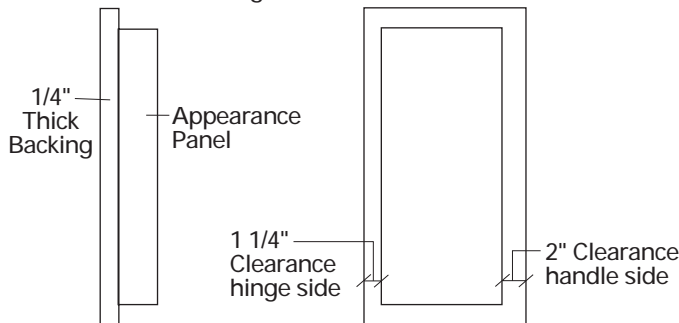

ZISW36D (white dispenser)
ZISB36D (black dispenser)

Standard Trim with 1/4" Panels

- 1/4" Panels: Cut panels to size.
- Custom handles with 1/4" door panels require Trim Kit ZKH1. When using ZKH1 with the standard dispenser trim, the length of the custom with handle, top to bottom cannot exceed 11-3/4".
- Tubular stainless steel handle kit, ZKHSS1.
- Custom collar dispenser trim with 1/4" door panels require trim kit ZWCD1.

Standard Trim with Panels secured to 1/4" thick backing

- Applying a raised panel design to a 1/4" thick backing (screwed or glued): Cut 1/4" panels to size, fabricate the raised panel to permit clearances of at least 2" from the handle side for fingertip clearance of the standard handle, 1-1/4" from the hinge side to avoid striking adjacent cabinetry and 5/16" from the top and bottom edges to allow for the trim flange, then install.
- Countertops adjacent to refrigerator installation should be mitered 45° degrees.

Note: ZWCD1 custom collar dispenser trim and ZKHT1 custom handle kits cannot be used in this configuration.

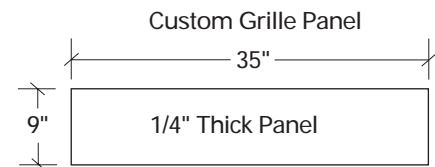

The grille panel frame is factory assembled for 84" installation height. If installation height varies, order ZG2 trim kit for optional side trim pieces. Cut grille panel to sizes shown below.

Installation Height	Panel Height
83"	8"
83-1/2"	8-1/2"
84-1/2"	9-1/2"

Important: Maintain 1-1/2" min. gap between top of doors and bottom of panel frame.

Custom Dispenser Cutout

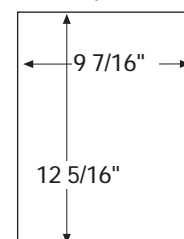

The Cutout is 9 7/16" wide by 12 5/16" high.

Custom Panel Dimensions

36" Built-In Refrigerator

Custom Door Panel Dimensions Using Trim Kit ZKT36 3/4" thick panel with standard handle and/or ZWCD1 custom collar trim

CUSTOM PANEL DIMENSIONS

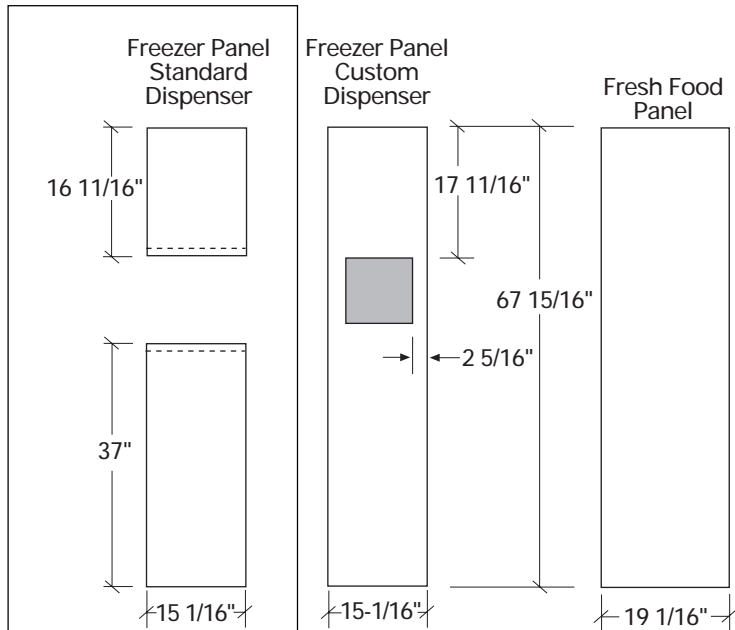

Important: Maximum weight for fresh food panels is 50 pounds and 30 pounds for freezer door panels.

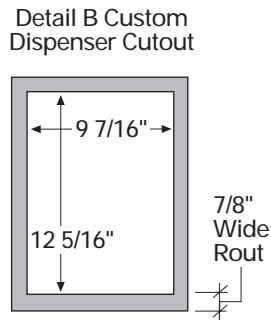
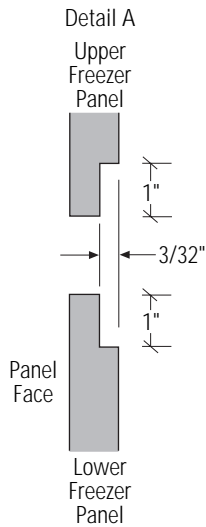

The Cutout is 9 7/16" wide by 12 5/16" high. 3/4" panels must be routed on all four sides of the cutout. Rout the back side of the panel 1/4" deep. 7/8" wide (shaded area).

ZISW36D (white dispenser)
ZISB36D (black dispenser)

- The ZKT36 trim kit provides for the installation of 3/4" custom door and grille panels, using the standard full-length handle. Cut panels to size and install.
- For standard dispenser trim: Cut panels to size, rout the bottom of the upper freezer panel and the top of the lower freezer panel to allow placement of support brackets and install (see detail A).
- For custom dispenser trim ZWCD1 kit must be used: Cut panels to size, refer to detail B for dispenser cutout routing instructions and install. When a raised panel design is used, a custom middle rail is required. A 14-1/2" wide middle rail must be used because the custom collar trim must be located within the raised portion of the panel. This area must be 3/4" thick. See detail C for raised panel design requirements.

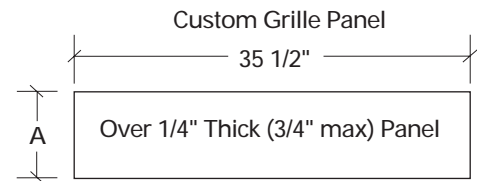

Grille Panel height can vary to fill installation height.

Installation Height	Dimension A
83"	8-1/4"
83-1/2"	8-3/4"
84"	9-1/4"
84-1/2"	9-3/4"

Important: Maintain 1-1/2" min. gap between top of doors and bottom of grille panel.

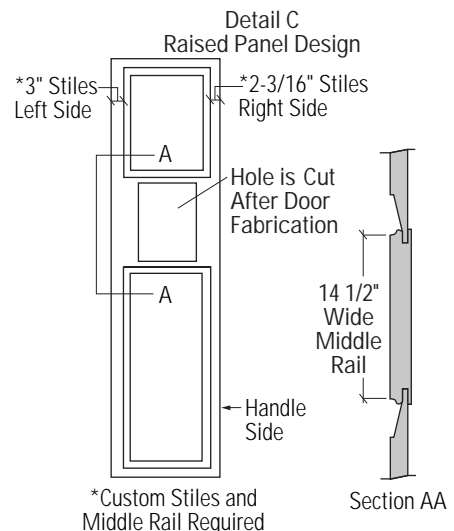

Custom Panel Dimensions

36" Built-In Refrigerator

CUSTOM PANEL DIMENSIONS

Custom Door Panel Dimensions Using Trim Kit ZKT36 3/4" thick panel with custom handle and/or ZWCD1 custom collar trim

ZISW36D (white dispenser)
ZISB36D (black dispenser)

- ZKT36 and ZKHT1 installed together provides for the installation of 3/4" custom door and grille panels, using a custom handle of your choice. Cut panels to size, rout the handle side of the panels as shown below and install (see detail B).
- For ZKHTSS1 tubular stainless steel handle kit, cut panels to size and rout the handle side of the panels as shown in detail B.
- For standard dispenser trim: Cut panels to size, rout the handle side of the panels as shown in detail B, rout the bottom of the upper freezer panel and the top of the lower freezer panel to allow placement of support brackets (see detail A) and install.
- For custom dispenser trim ZWCD1 kit must be used: Cut panels to size, refer to detail C for dispenser cutout routing instructions. When a raised panel design is used, a custom middle rail is required. A 14-1/2" wide middle rail must be used because the custom collar trim must be located within the raised portion of the panel. This area must be 3/4" thick. See detail D for raised panel design requirements.
- When using the standard full-width dispenser trim, the length of the custom handle, top to bottom cannot exceed 11-3/4". Locate the handle a minimum of 3/4" and a maximum of 1-1/2" from the edge of the panel. There are no length restrictions on handles for models using a custom collar dispenser trim (ZWCD1).

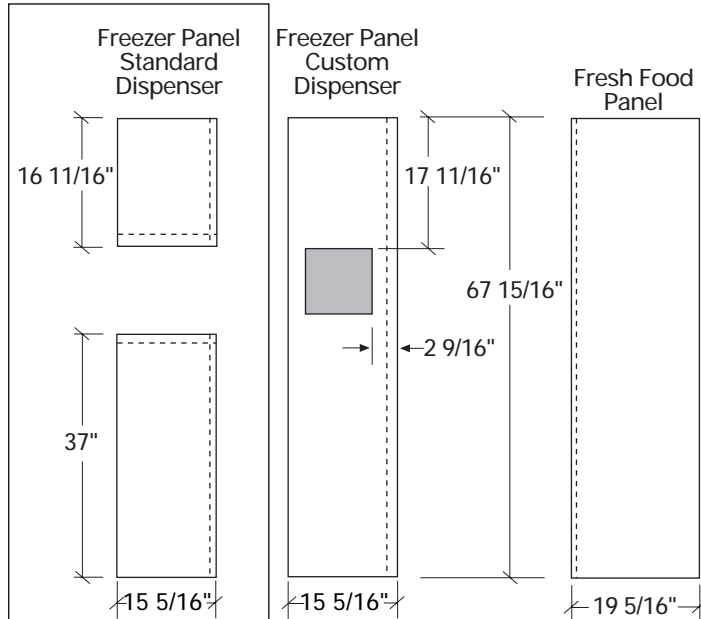

Important: Maximum weight for fresh food panels is 50 pounds and 30 pounds for freezer door panels.

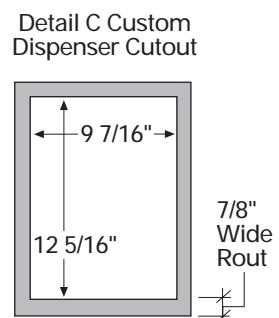
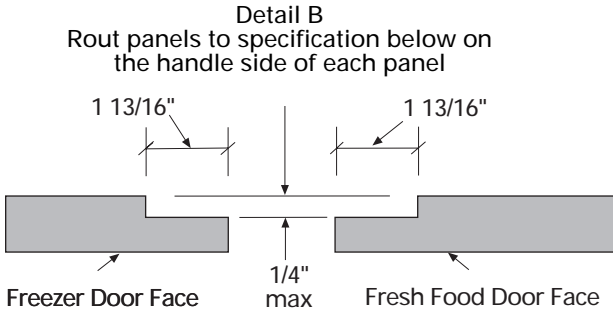
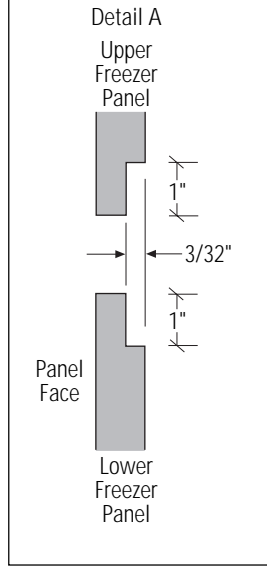

The Cutout is 9 7/16" wide by 12 5/16" high. 3/4" panels must be routed on all four sides of the cutout. Rout the back side of the panel 1/4" deep. 7/8" wide (shaded area).

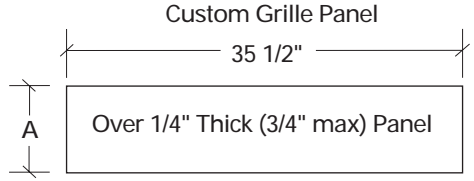

Grille Panel height can vary to fill installation height.

Installation Height	Dimension A
83"	8-1/4"
83-1/2"	8-3/4"
84"	9-1/4"
84-1/2"	9-3/4"

Important: Maintain 1-1/2" min. gap between top of doors and bottom of grille panel.

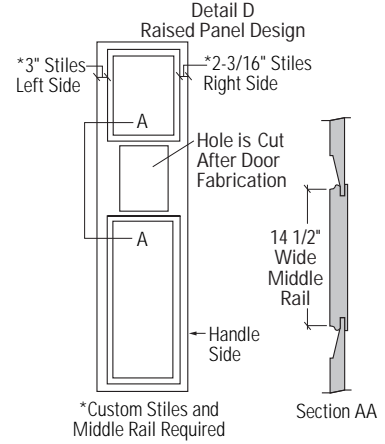

Side Panel or Filler Options (not to scale)

Side panels must be used whenever the sides of the refrigerator will be exposed.

For All Monogram Built-In Refrigerators

CUSTOM PANEL DIMENSIONS

1/4" Side Panels
Insert end of side panel into trim.

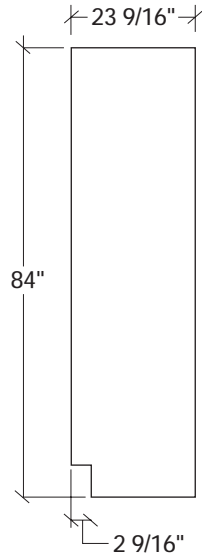
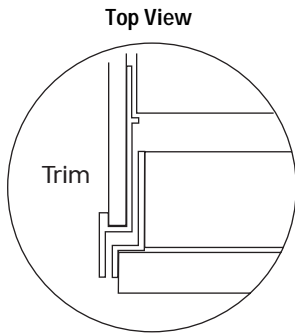

Standard 4" high toe-kick or trim to fit.
Height may vary depending on application.

1/2" to 3/4" Side Panels
Leading Edge
Flush with Cabinet
Front. The front or
leading edge, must be
finished to match
cabinetry.

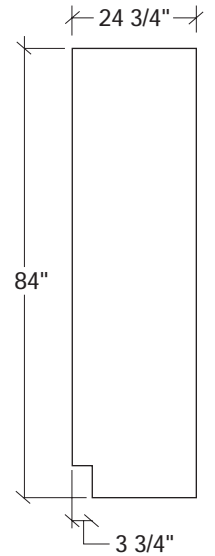
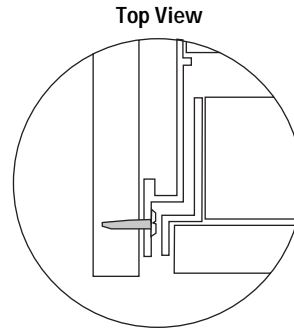

Standard 4" high toe-kick or trim to fit.
Height may vary depending on application.

1/2" to 3/4" Side Panels
Recessed front edge.

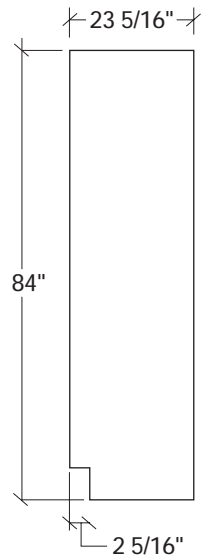
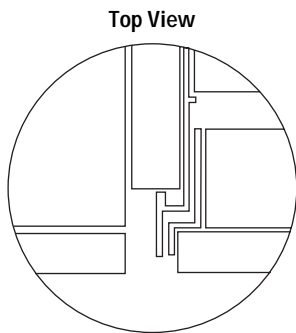

Standard 4" high toe-kick or trim to fit.
Height may vary depending on application.

Installation

36" Built-In Refrigerator

PRODUCT
INSTALLATION

Tools Required

- Tinsnips to cut banding
- Stepladder
- 1-1/2" open-end wrench
- Bucket
- Level
- Appliance Hand Truck
- Tubing cutter
- 7/16" open-end wrench
- #2 Phillips screwdriver
- Stubby Phillips screwdriver
- Drill and appropriate bits
- 7/16" socket with 3" extension for ratchet
- Safety glasses

Hardware Supplied

- Special velcro adhesive strips for 1/4" side panels
- 1/4-1/4 union with nuts
- 1/4" panel foam spacers

Materials Required

- Water shut-off valve (optional but recommended)
- Custom panels for fresh food, freezer compartments, grille panel
- Side panels
- Hardware for side panel installation.
- 36" long 2x4 for Anti-Tip support

Flooring

For proper installation, this refrigerator must be placed on a level surface of hard material that is at the same height as the rest of the flooring. This surface should be strong enough to support a fully loaded refrigerator.

Note: Protect the finish of the flooring. Cut a large section of the cardboard carton and place under the refrigerator where you are working.

Grounding the Refrigerator

IMPORTANT - (Please read carefully)

FOR PERSONAL SAFETY, THIS APPLIANCE MUST BE PROPERLY GROUNDED.

The power cord of this appliance is equipped with a three-prong (grounding) plug which mates with a standard three-prong (grounding) wall receptacle to minimize the possibility of electric shock hazard from this appliance.

Have the wall outlet and circuit checked by a qualified electrician to make sure the outlet is properly grounded.

Where a standard 2-prong wall outlet is encountered, it is your personal responsibility and obligation to have it replaced with a properly grounded 3-prong wall outlet.

DO NOT, UNDER ANY CIRCUMSTANCES, CUT OR REMOVE THE THIRD (GROUND) PRONG FROM THE POWER CORD.

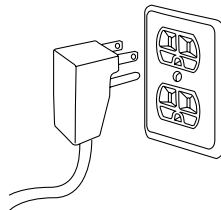

Use of Adapter plug

Because of potential hazards under certain conditions, we strongly recommend against use of an adapter plug. However, if you still elect to use an adapter, where local codes permit, a TEMPORARY CONNECTION, may be made to a properly grounded 2-prong wall outlet by use of a UL listed adapter available at most hardware stores.

The larger slot in the adapter must be aligned with the larger slot in the wall outlet to provide proper polarity in the connection of the power cord.

CAUTION

Attaching the adapter ground terminal to a wall outlet cover screw does not ground the appliance unless the cover screw is metal, and not insulated, and the wall outlet is grounded through the house wiring. You should have the circuit checked by a qualified electrician to make sure the outlet is properly grounded.

When disconnecting the power cord from the adapter, always hold the adapter in place with one hand and pulling the power cord with the other hand. If this is not done, the adapter ground terminal is very likely to break with repeated use.

Should the adapter ground terminal break, DO NOT USE the appliance until a proper ground has again been established.

Use of Extension Cords

Because of potential safety hazards under certain conditions, we strongly recommend against the use of an extension cord. However, if you still elect to use an extension cord, it is absolutely necessary that it be a UL listed 3-wire grounding type appliance extension cord having a grounding type plug and outlet and that the electrical rating of the cord be 15 amperes (minimum) and 120 volts.

PRUDENCE

FICHE D'ADAPTATION
(Fiches d'adaptation non permises au Canada)

Installation

36" Built-In Refrigerator

Step 1
Remove
Packaging

PRODUCT
INSTALLATION

CAUTION
Refrigerator is much heavier at the top than at the bottom – be careful when moving. When using a hand truck, handle from side only.

PRUDENCE
Le réfrigérateur est beaucoup plus lourd en haut qu'en bas. Il faut être prudent lors des déplacements. Si un diable est utilisé, il faut soulever le réfrigérateur sur le côté seulement.

- Remove outer carton.
 - Carefully cut banding at the top and bottom.
 - Slide out back corner posts (2).
 - Slide carton off top of cabinet.
- NOTE: IT IS NOT NECESSARY TO LAY CABINET DOWN IN ORDER TO REMOVE SKID!
- To remove skid, remove the four 7/16" bolts and their brackets.

CAUTION
DO NOT ATTEMPT TO ROLL UNIT OFF SKID.

PRUDENCE
IL NE FAUT PAS ESSAYER DE FAIRE ROULER LE RÉFRIGÉRATEUR POUR L'ENLEVER DE LA PALETTE.

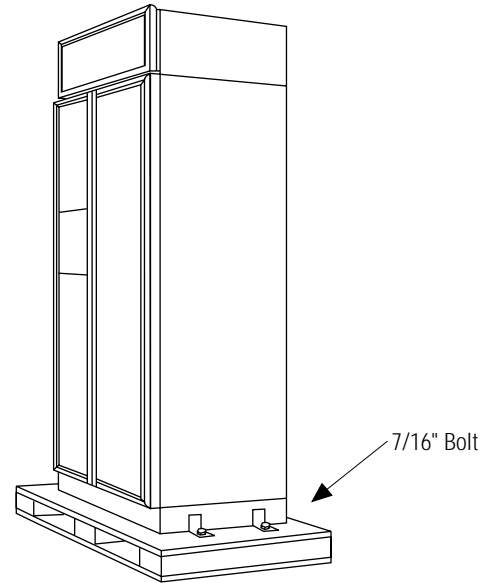

- There are support blocks on the bottom of the cabinet and door. They must be removed before sliding unit off the skid or damage will occur.
- Carefully, tilt cabinet and slide blocks out from beneath cabinet, slide unit off skid.
- Remove toekick from fresh food compartment and set aside for later installation.

Step 2
Install
Water Line

- A cold water supply is required for automatic icemaker operation. The water pressure must be between 40 and 120 p.s.i.
- Route 1/4" OD copper tubing between house cold water line and the water connection location.
- Copper tubing should be long enough to extend to the front of the refrigerator. Allow enough to accommodate bend leading into the water valve.

Shut off the main water supply.

Turn on the nearest faucet long enough to clear the line of water.

- Install a shut-off valve between the icemaker water valve and cold water pipe in a basement or cabinet. The shut-off valve should be located where it will be easily accessible.

NOTE: It is best to install the valve into a vertical water pipe. If you install the valve into a horizontal water pipe, make the connection at the top or side, rather than at the bottom, to avoid drawing off any sediment from the water pipe.

- Drill a 1/4" hole in the water pipe.
- Fasten the shut-off valve to the pipe with pipe clamp.
- Tighten the clamp screws until the sealing washer begins to swell. Do not over tighten.
- Place a compression nut and ferrule (sleeve) onto the end of the tubing and connect it to the shut-off valve. Make sure the tubing is fully inserted into the valve and ferrule is tightened.
- Turn on the main water supply and flush debris from the line. Run about a quart of water through the tubing into a bucket. Shut off water supply at the shut-off valve.

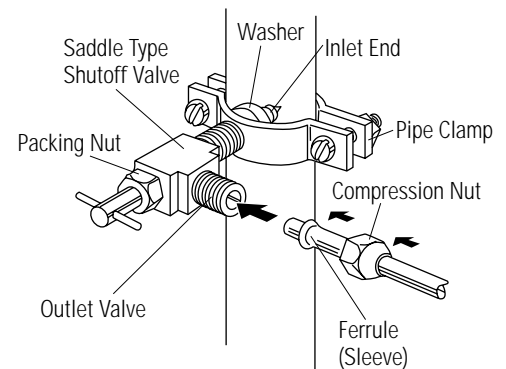
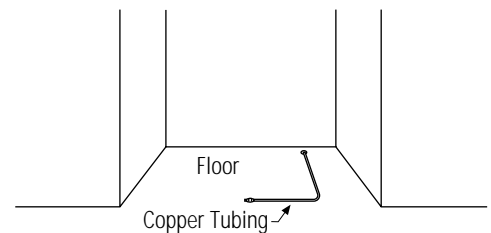

NOTE: Saddle type shut-off valves are included in many water supply kits. Before purchasing, make sure a saddle type valve complies with your local plumbing codes.

NOTE: Commonwealth of Massachusetts Plumbing Codes 248CMR shall be adhered to. Saddle valves are illegal and use is not permitted in Massachusetts. Consult with your licensed plumber.

Installation

36" Built-In Refrigerator

Step 2A
For Installations
With A Reverse
Osmosis System
Only

Skip This
Step When
Not Using
RO System

WARNING

When connecting a GE Reverse Osmosis Water System to your refrigerator, the only approved installation is with a GE RVKIT.

If the water supply to the refrigerator is from a Reverse Osmosis Water System AND the refrigerator also has a water filter, use the refrigerator's filter bypass plug. Using the refrigerator's water filtration cartridge in conjunction with the RO filter can result in hollow ice cubes and slower water flow from the water dispenser.

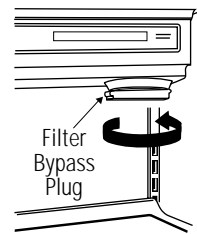
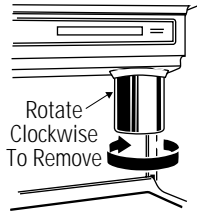

ATTENTION

Lors du raccordement au réfrigérateur du système GE de purification de l'eau par osmose inversée seule l'installation avec un ensemble GE RVKIT est approuvée.

Si le réfrigérateur es alimenté en eau à partir d'un système de filtration d'eau par osmose inversée, et si le réfrigérateur comporte également un filtre à eau, utiliser le bouchon du circuit de dérivation du filtre du réfrigérateur. Si la cartouche de filtration d'eau du réfrigérateur est utilisée en conjonction avec le système de filtration par osmose inversée, on peut observer une réduction du débit d'eau au point de puisage, et la production de cubes de glace creux.

If you use the bypass Plug and want a light shield without the filter opening, order a replacement solid light shield WR02X3025.

PRODUCT
INSTALLATION

Step 3
Install
Side Panels

- Side panels are not required when the refrigerator is installed into an enclosure. Skip this step if you are installing in an enclosure.
- Side panels are required whenever the sides of the refrigerator will be exposed and when installed between frameless cabinets. See pages 3 and 4.
- Side panel installation will be determined by the design of the side panel you have previously chosen.
- Side panels must be installed plumb.
- If you choose to use 1/4" side panels, they should be inserted into the case trim as illustrated. Fasten the panels to the refrigerator with Velcro strips (provided) before setting refrigerator in place. See illustration A.
- 1/2" to 3/4" side panels are normally set into place and fastened to adjacent cabinetry or the back wall before rolling the refrigerator into the opening. See illustrations B and C.

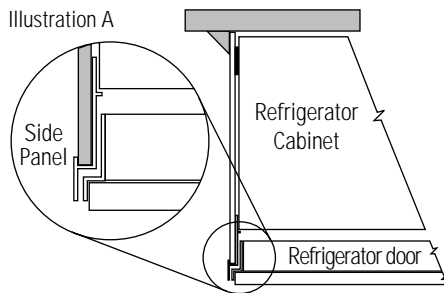

1/4" Side Panels – Insert End Of Side Panel Into Case Trim. Fasten With Velcro Strips provided.

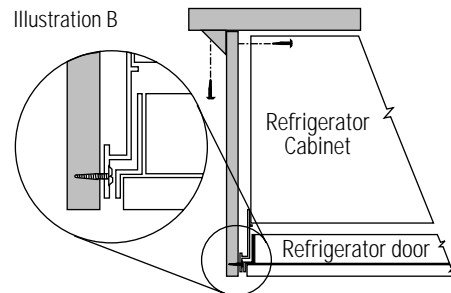

1/2" to 3/4" Side Panels – Leading Edge Of Side Panel Is Flush With Cabinet front. Fasten To The Back Wall Using A Cleat.

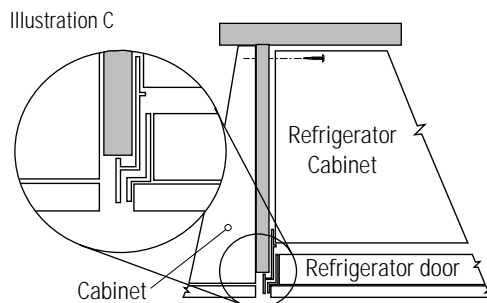

1/2" to 3/4" Side Panels – Recessed Front Edge of Side Panel. Fasten To Adjacent Cabinet.

Installation

36" Built-In Refrigerator

Step 4 Roll Refrigerator Into Opening

- Gently push refrigerator into opening with hands against front corners. The cardboard protective pad should be beneath the refrigerator.
- Roll refrigerator into the opening until it is flush with adjacent cabinets.

Step 5 Level Refrigerator

- All models have 4-point leveling. The front is supported by leveling legs, the rear is supported by wheels.
- To level the back of the refrigerator, turn the 7/16" hex nut located above the front wheels. Turn to raise or lower the refrigerator.
 - For front leveling, use a 1-1/2" open-end wrench.
 - Adjust carefully, the refrigerator should be level and plumb with cabinetry, and should align with toekick height.

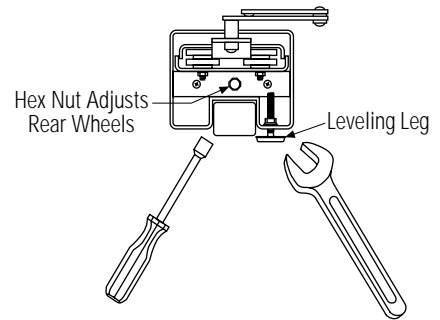

Step 6 Install 1/4" Door Panels

If you are using 3/4" thick custom panels, SKIP THIS STEP. See Custom Panel Dimensions pages for panel sizes with ZKT36 trim kit and other kits. Refer to trim kit installation instructions in this booklet.

If you are using the custom collar dispenser trim, order ZWCD1 trim kit.

To install 1/4" door panels:

- Open door to 90° stop. Remove the Phillips head screws from the aluminum trim door handles. Retain all screws.

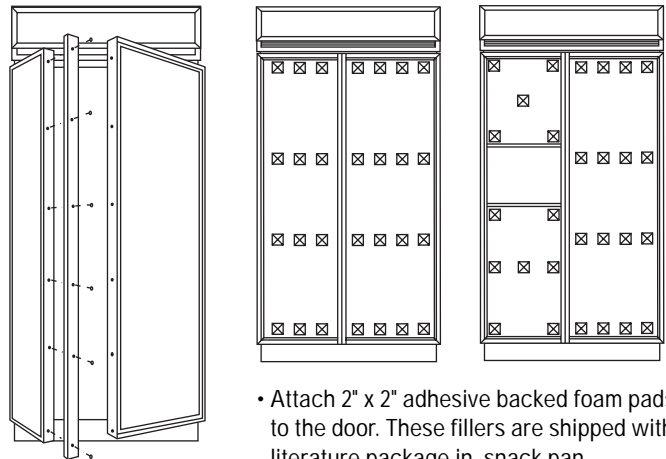

- Attach 2" x 2" adhesive backed foam pads to the door. These fillers are shipped with literature package in snack pan.

- Slide panel into the door trim.
- Replace door handles and secure with original screws.
- Again, check to be sure unit is level and that panels align with cabinetry. Doors will not close properly if unit is not level.
- Check for noises caused by incomplete alignment (rubbing of panels, trim or screws).

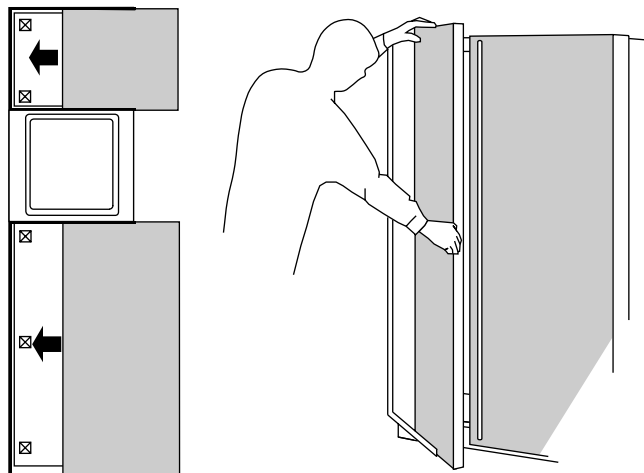

Installation

36" Built-In Refrigerator

PRODUCT
INSTALLATION

Step 7
OPTION 1
Secure
refrigerator
at the top

⚠ WARNING

ANTI-TIP PRECAUTIONS
The refrigerator is heavy at the top and must be secured to prevent the possibility of tipping forward.

⚠ ATTENTION

PRECAUTIONS CONTRE LES BASCULEMENTS
Le réfrigérateur est beaucoup plus lourd en haut et il faut le maintenir en place pour éviter la possibilité de son basculement vers l'avant.

To prevent the refrigerator from tipping over, you must:

- Install a wood block, the full width of the refrigerator.
- Secure the block with wood screws penetrating at least 3/4" into wall studs.

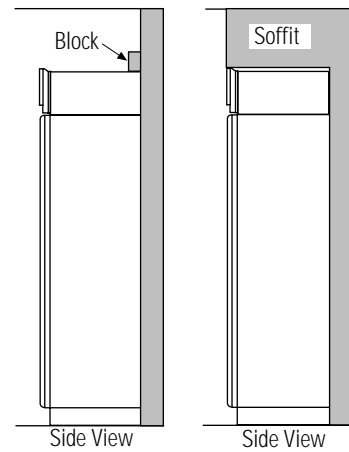

OPTION 2
Secure
refrigerator
at the sides

When using 1/2" to 3/4" side panels, the front flange of the case trim is attached to the side panel.

- Open freezer door to access case trim.
- Drill hole in case trim slightly below top hinge. Drive screw through the trim and into the side panel.
- Follow the same procedure on the fresh food side.

OR

If refrigerator is installed between cabinets with no side panels or in a custom enclosure, install a spacer block as shown.

- Open freezer door to access case trim.
- Drill hole in case trim slightly below top hinge. Drive screw through the trim and into the spacer block.
- Follow the same procedure for fresh food side.

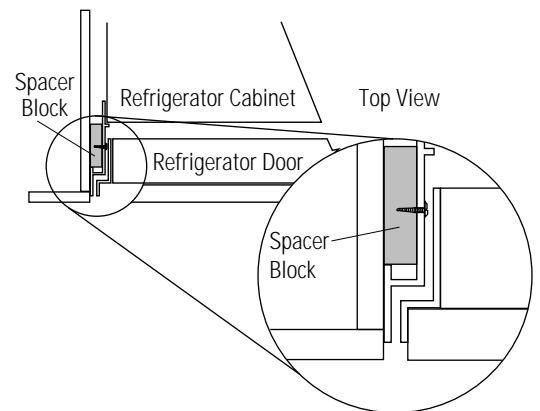
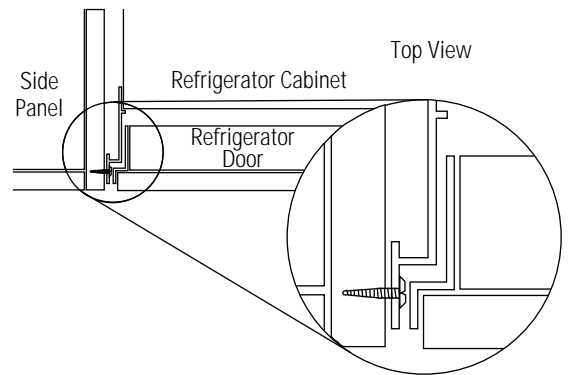

Step 8
Connect
Water
Supply

Check to be sure that refrigerator power cord is not plugged into the wall outlet.

- Locate and bring copper tubing to the front of the cabinet.
- Turn the water on to flush debris from line, run about a quart of water through tubing into a bucket, then shut-off water.
- Slip a 1/4-1/4 union nut (provided) over both ends of the copper tubing at the right front leg of then refrigerator and couple the lines.
- Turn on the water to check for leaks.

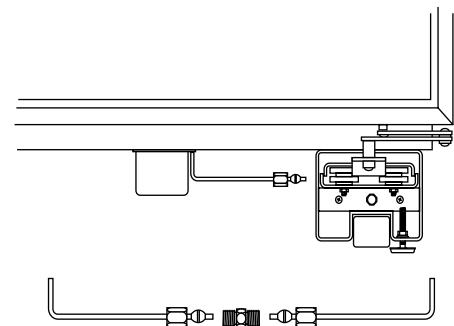

Installation

36" Built-In Refrigerator

Step 9
Connect
power

- Connect refrigerator power cord plug to properly grounded receptacle, accessible through the top right side of the grille opening.
- Check to make sure power to refrigerator is on by opening refrigerator door to see if interior lights are on.

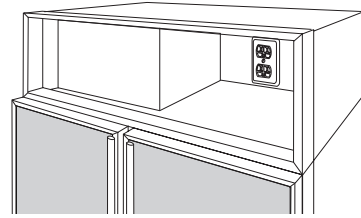

PRODUCT
INSTALLATION

Step 10
Mount
Top Grille
Panel

If you are using 3/4" thick custom panels, **SKIP THIS STEP.** See Custom Panel Dimensions for grille panel sizes. Order ZKT36 kit and follow the installation instructions packed with the kit.

The grille panel frame is factory assembled for an 84" installation height. If installation height varies, order ZG2 trim kit which provides optional side trim pieces.

Cut 1/4" thick custom panel to fit the frame, 35" wide, 9" deep.

To insert decorative grille panel into the frame:

- Remove screws (2 on each top corner) and "L" brackets on each side.
- Slide panel into the frame and reassemble.
- Mount the grille panel by dropping into slots on the case trim.

For shipping purposes, the top case trim is secured at 84" installation height.

To raise or lower case trim to other installation heights:

- Loosen 2 screws on both sides and raise the top case trim to meet soffit height or to the top of adjacent cabinets.
- Tighten all 4 screws.

If installation height is more or less than 84", order ZG2 optional grille panel kit which accommodates 83", 83-1/2" and 84-1/2" heights. See installation instructions page 26.

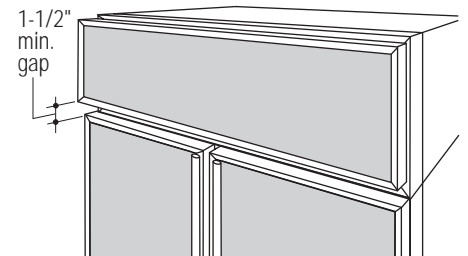
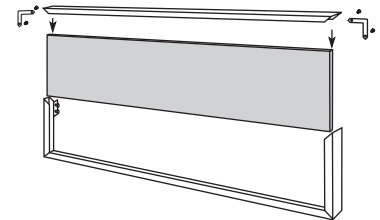
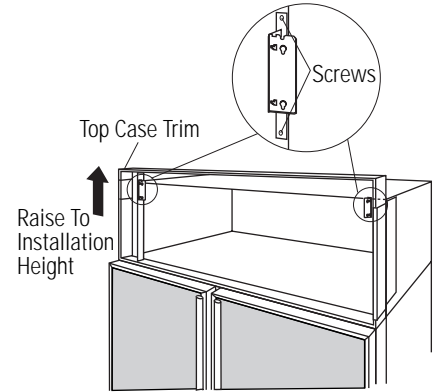

Important: Maintain 1-1/2" min. gap between top of doors and bottom of panel frame.

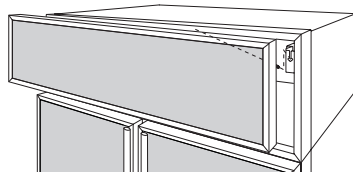

Step 11
Install
Toekick

- A standard toekick is supplied. Install with 2 screws provided, adjust to desired height and tighten screws.
- A custom toekick can be installed to match or complement the surrounding cabinetry.
 - If a custom toekick is to be installed, use the supplied toekick as a template to cut out notches around hinges and waterline tubing.
- For 1/2" to 3/4" thick custom toekicks, additional material should be removed and cut away. This will allow the water and electrical umbilical tube to rotate smoothly when the door is fully opened.

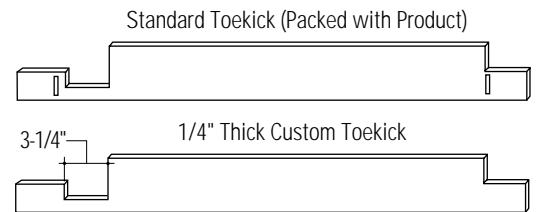

1/2" to 3/4" Thick Custom Toekick Remove Additional Material

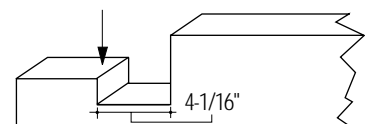

ZKH1 Trim Kit (For 1/4" Panels)

Support for Custom Handles

Tools and materials

required:

- #2 Phillips screwdriver
- Drill and appropriate bits
- Custom door panels
- Custom handles
- Safety glasses

These instructions are divided into 2 options:

Option 1—For non-dispenser and dispenser models using custom collar trim.

Option 2—For dispenser model using the standard full-width trim.

Kit contents

Parts List:

- A. Fresh food door extrusion
- B. Freezer door extrusion for non-dispenser model and dispenser model using custom collar. (Option 1)
- C. Freezer door extrusion for dispenser model using full-width trim. (Option 2)
- D. Handle bracket for dispenser model using full-width trim. (Option 2)

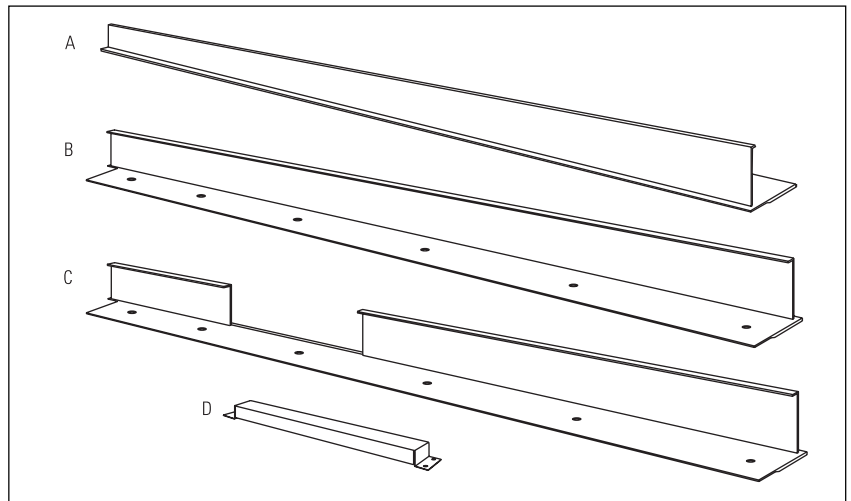

ZKH1
INSTALLATION

This kit provides the necessary framework to install custom handles, of your choice, onto 1/4" thick decorator door panels. (Handles not included.) The door extrusions and bracket allow custom handles to be secured to the door structure, rather than the door panels. This kit contains all the necessary parts for

dispenser and non-dispenser models. Follow the instructions for Option 1 when applying custom handles to a non-dispenser model or dispenser model using custom collar trim. Follow instructions in Option 2 for a dispenser model using the standard full-width dispenser trim.

OPTION 1 For non-dispenser model or dispenser model using custom collar trim

Step 1 Remove handles

- Open doors to 90°. Remove the screws from the full-length aluminum handles of both doors.
- Retain screws, discard handles.

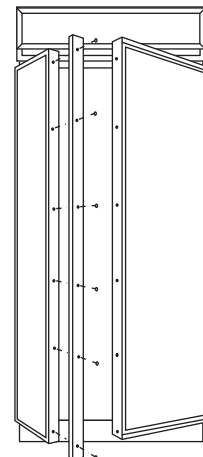

Note: If a custom collar is to be used, order ZWCD1 Trim Kit.

ZKH1 Trim Kit (For 1/4" Panels)

Support for Custom Handles

Option 1 Installation

Step 2
Locate position
of handles

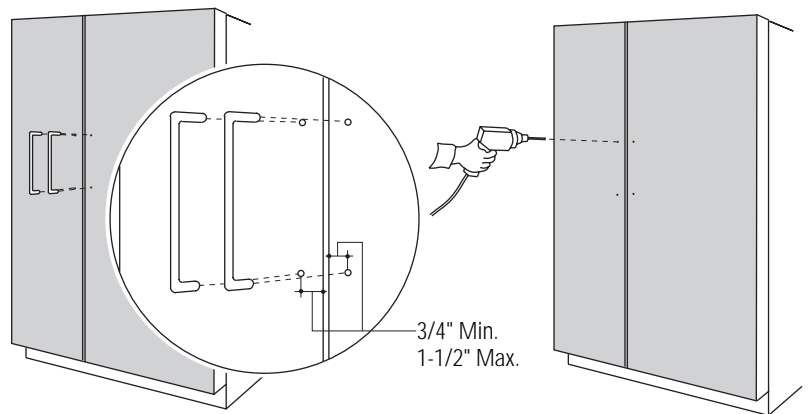
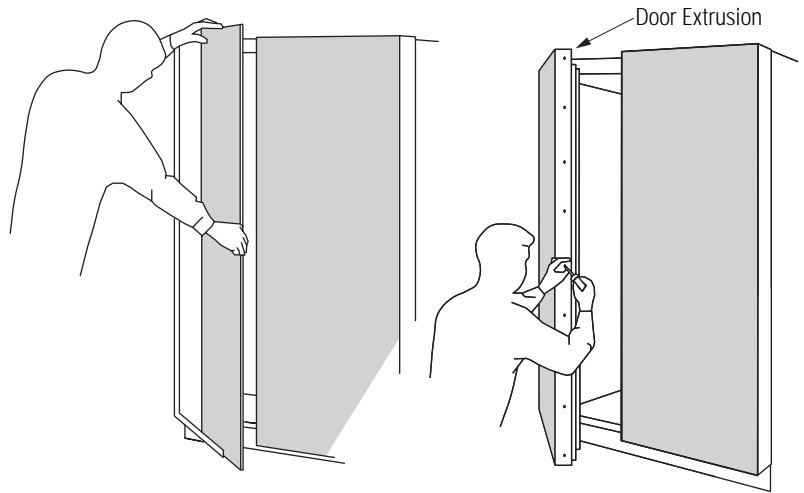

Note: Handle must be located 3/4" to 1-1/2" from edge of extrusion.

- Slide custom panels into fresh food and freezer door frames.
- Temporarily secure the new door extrusions to the doors. Use at least 2 screws on each door.
- The handles must be located 3/4" to 1-1/2" from the edge of the extrusion.
- Determine the desired location of the custom handles and carefully mark centerlines of the screw holes.
- Again, with both doors closed, check the location of the centerlines to be sure they are parallel to the edge of the door, and level with opposite door.
- Drill 1/16" pilot hole through the panel until it starts into the aluminum extrusion. This will mark the matching location for drilling the clearance hole when assembling the handle, panel and extrusion.

Option 1 Installation

Step 3 Assemble panel, extrusion and handle

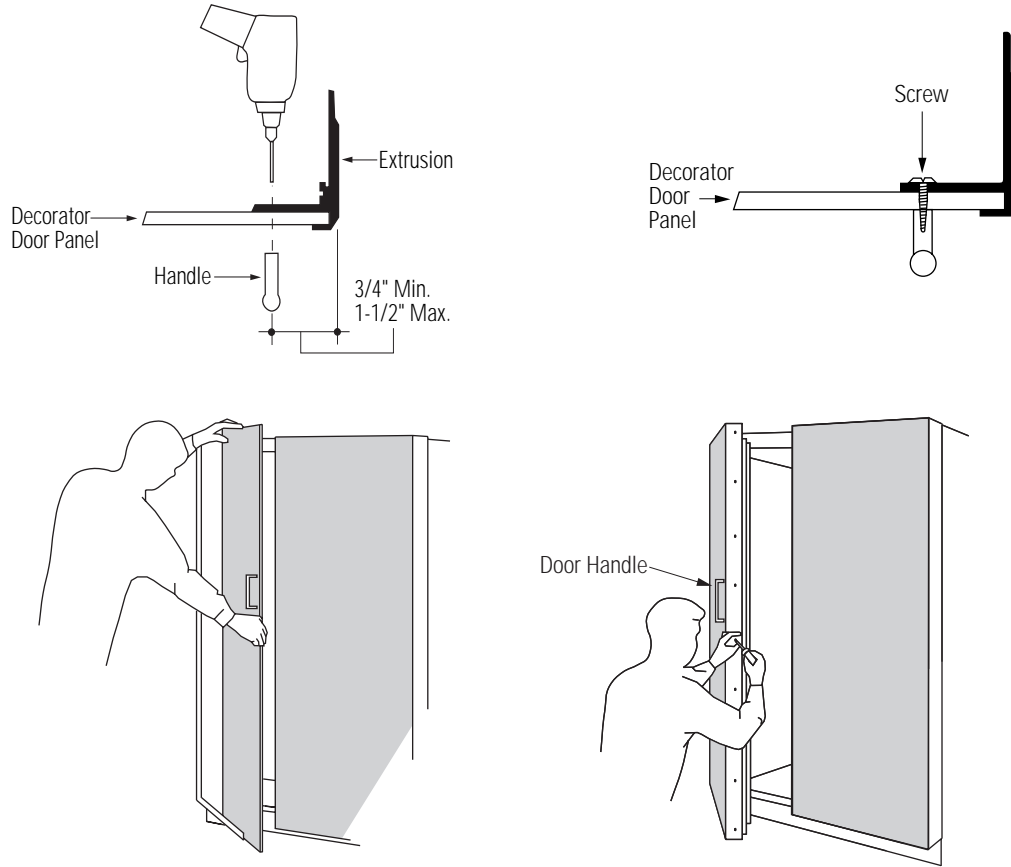

- Remove the door extrusions and door panels.
- Drill 1/16" pilot hole through extrusion.
- Drill clearance holes through the panel and extrusion.
- Assemble the door panel, extrusion and custom handle.
- Install screw(s) long enough to pass through the extrusion, door panel and into the handle.
- Slide the assembly into the door frame until the new extrusion fits firmly against the steel door.
- Re-install original screws into the door extrusion.

ZKH1 Trim Kit (For 1/4" Panels)

Support for Custom Handles

OPTION 2
For dispenser model
using full-width
trim

- Open door to 90°. Remove the screws from the full-length aluminum handle of the freezer door.
- Retain screws, discard handle.

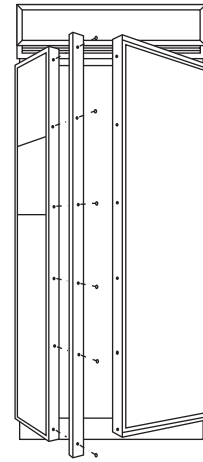

Step 1
Remove handles

ZKH1
INSTALLATION

Step 2
Remove trim

Remove door panel trim above and below dispenser. Lift off dispenser trim. Retain screws and trim.

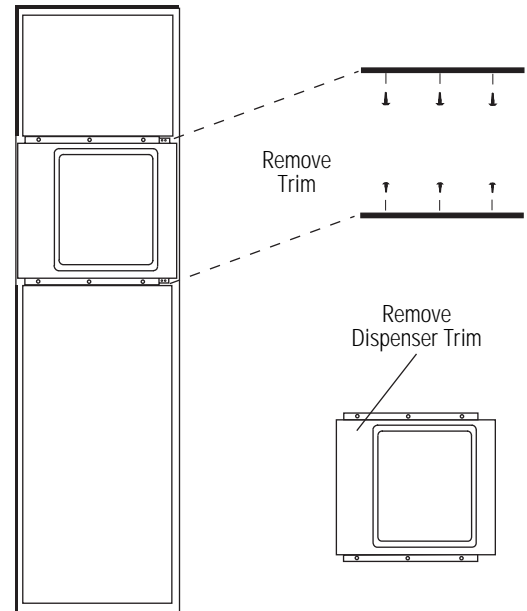

Step 3
Locate
position
of handle

- Position the handle bracket onto the steel door by matching existing screw holes on the door and bracket. Temporarily secure with screws.
- Re-install dispenser trim, temporarily.
- Determine the desired location of the custom handle and carefully mark centerlines of the screw holes.
- Drill 1/16" pilot hole through the trim until it starts into the handle bracket. This will mark the matching location for drilling a clearance hole when assembling the handle, bracket and dispenser trim.
- Remove dispenser trim and bracket.

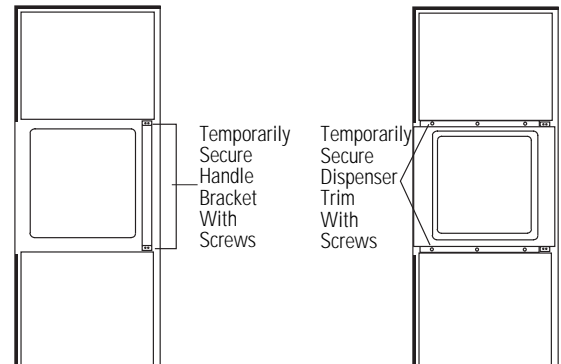
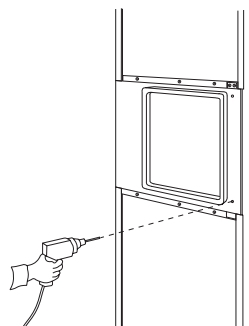

ZKH1 Trim Kit (For 1/4" Panels)

Support for Custom Handles

Option 2 Installation

Step 4 Install custom handle

- Drill clearance holes through the handle bracket and the dispenser trim.
- Install screw(s) long enough to pass through the handle bracket, dispenser trim and into the custom handle.

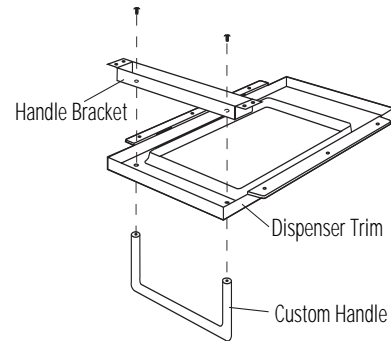
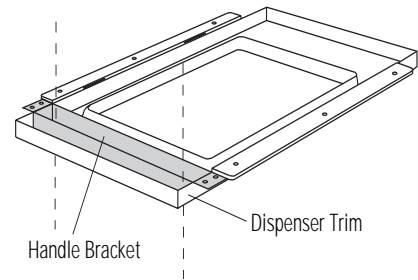

Note: The custom handle must be installed against the handle bracket. The custom handle cannot exceed 11-3/4" length.

Step 5 Mount assembled dispenser trim

- Mount assembled dispenser trim with handle onto the door.
- Drive 2 screws through the top and bottom of the handle bracket into the steel door.
- Re-install 3 screws at top and bottom of dispenser trim.

Important: The handle bracket must be secured to the steel door. If it is not secured properly, the dispenser trim will pull away from the door.

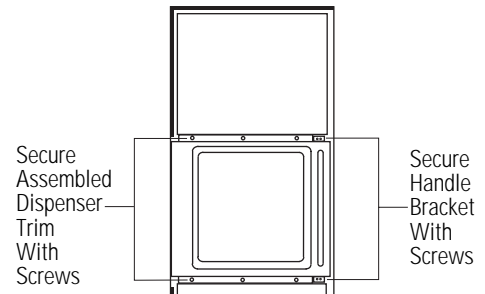

Step 6 Install custom handle extrusion

- Slide decorator panels into the trim, top and bottom.
- Slide freezer door extrusion in between panels and steel door. Secure with screws.
- To install fresh food handle follow the same procedure as shown in Option 1.

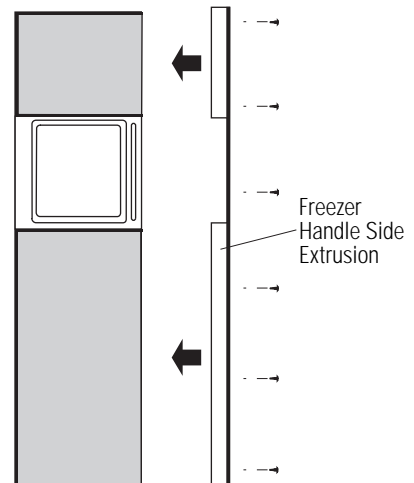

ZKH1
INSTALLATION

ZG2 Trim Kit

Grille Panel Frame Adjustment

FOR 83", 83-1/2" AND 84-1/2" INSTALLATION HEIGHTS

- This kit provides optional side trim pieces for the original grille frame to fit 83", 83-1/2" or 84-1/2" installation heights.

To change grille panel size:

- Determine the installation height by measuring the enclosure from the floor to the underside of soffit. When there is no soffit, measure to the top of adjacent cabinets.
- Adjust refrigerator case trim to desired height. See Production Installation.
- Select the side trim pieces for your installation height.

Installation Height	Panel Width	Side Trim Lengths	Panel Height
83"	35"	8-1/4"	8"
83-1/2"	35"	8-3/4"	8-1/2"
84-1/2"	35"	9-3/4"	9-1/2"

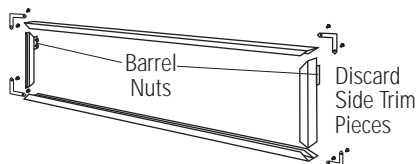

- Locate original grille panel frame supplied with the refrigerator.
- Remove 8 screws (two on each corner) as illustrated. Discard original side trim pieces.
- Select correct size of side trim pieces (3 sets provided).
- Secure new side trim pieces to original bottom trim.

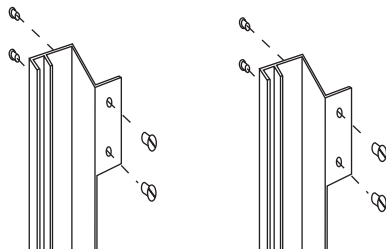

- Remove barrel nuts from original side trim pieces (2 each side).
- Re-install the barrel nuts on the new side trim pieces you have selected.

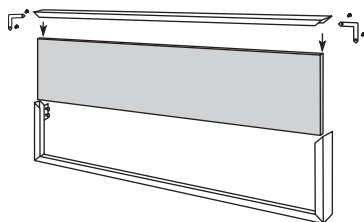

- Slide custom panel into front slots.
- Secure the top trim piece to the frame with "L" brackets and screws.

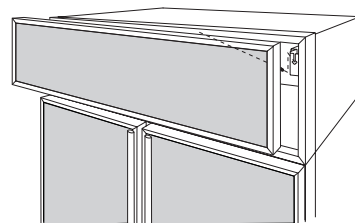

- Mount the assembled panel by dropping into slots on the case trim.

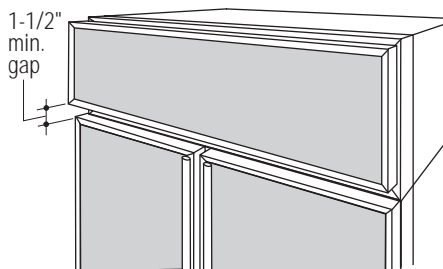

Important: Maintain 1-1/2" min. gap between top of doors and bottom of grille panel.

Note: ZG1 Grille Panel Kit is available for models produced before January 1997. Panel sizes for ZG1 and ZG2 are the same. The ZG1 kit can be ordered from your Monogram dealer.

ZKT36 Trim Kit

3/4" Custom Panels

Tools and materials required:

- #2 Phillips screwdriver
- Stubby Phillips screwdriver
- Drill and appropriate bits
- Safety glasses
- Custom panels

These instructions are divided into 2 options:

- Option 1—For non-dispenser and dispenser models using custom collar trim.
- Option 2—For dispenser model using the standard full-width trim.

Kit contents

Parts List:

Freezer Door

- A. Top trim
- B. Side trim
- C. Bottom trim

Fresh Food Door

- D. Top trim
- E. Side trim
- F. Bottom trim
- G. Panel support brackets (4)
- H. 4-3/8" screws for support brackets (20)
- I. Grille support panel and screws
- J. Wood screws #6 1/2" flat-head screws
- ZKT36-6 screws
- ZKT36-30 screws

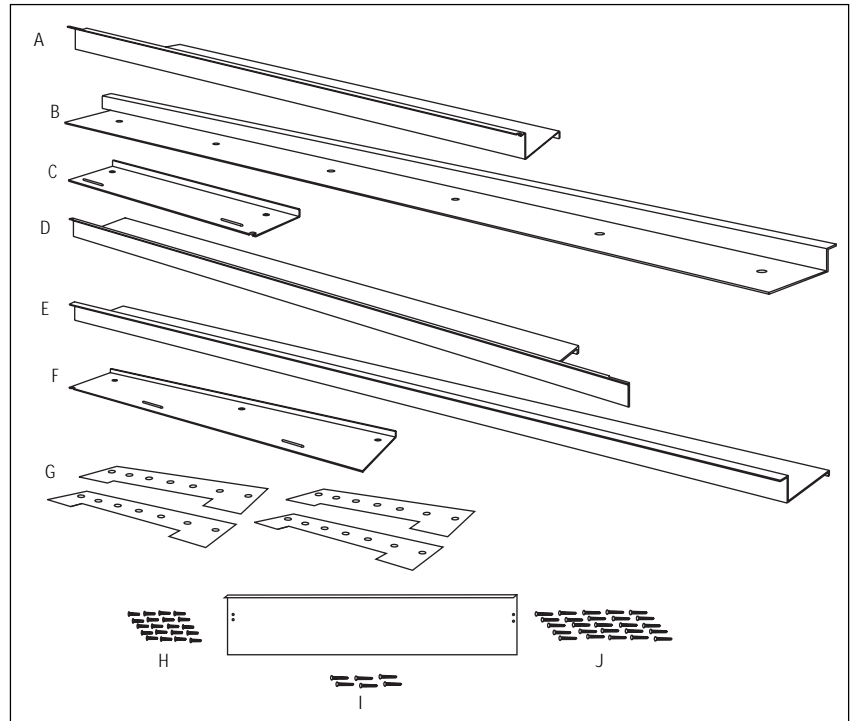

This kit provides for the installation of 3/4" custom door and grille panels, using the standard full length handle. This kit contains all the necessary parts to apply 3/4" panels on dispenser and non-dispenser models. Follow the instructions for Option 1 when applying custom panels to a non-dispenser model or dispenser model using custom collar trim. Follow instructions in Option 2 for a dispenser model using the standard full-width dispenser trim.

Note: If you are using custom handles, see ZKHT1 Installation Instructions. For tubular stainless steel handles, see ZKHTSS1 Installation Instructions.

ZKT36 Trim Kit

3/4" Custom Panels

OPTION 1
For non-dispenser
model
or dispenser model
using custom
collar trim

Step 1
Remove
handles & trim

- Open door to 90°.
- Remove the Phillips head screws from the full-length handles.
- Open the doors fully to stop.
- Remove the screws from the aluminum trim, top, bottom and hinge side.
- Retain screws. Discard original trim.

Note: If a custom collar is to be used, order ZWCD1 trim kit. If a custom handle is to be used, order ZKHT1 trim kit.

Important: When the bottom trim piece is removed, an aluminum shim secured to the bottom of the door can be seen. Do not attempt to remove this piece.

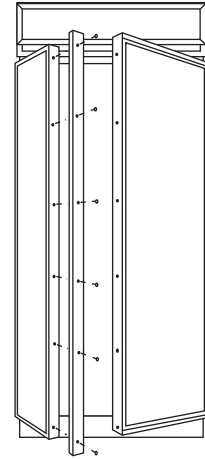

Step 2
Install
3/4" trim

- Attach the new 3/4" trim pieces on the top, hinge side and bottom using original screws.

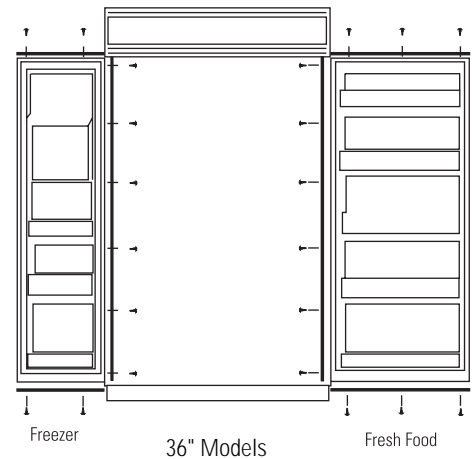

ZKT36
INSTALLATION

ZKT36 Trim Kit

3/4" Custom Panels

Option 1 Installation

Step 3 Apply panel support brackets

Dimension A
ZKT36-6-3/4"

Dimension B
ZKT36-7-7/8"

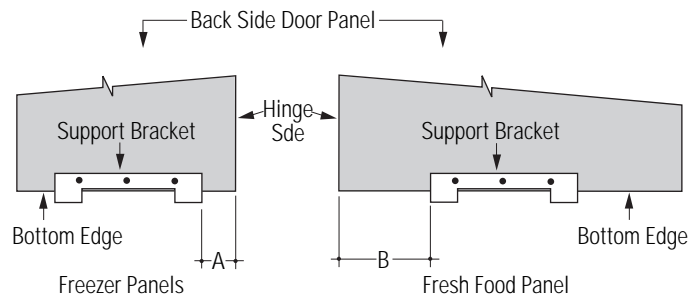

- Position support bracket on freezer panel, dimension A, from the hinge side edge.
- Position support bracket on fresh food panel, dimension B, from the hinge side edge.

- Secure support brackets to the bottom of the panels with #4 screws provided. Align the brackets flush with the bottom of the panels, with tabs protruding below.
- Bracket location measured from the hinge side, is the same for panels with custom handles or standard handles.

Step 4 Install panels

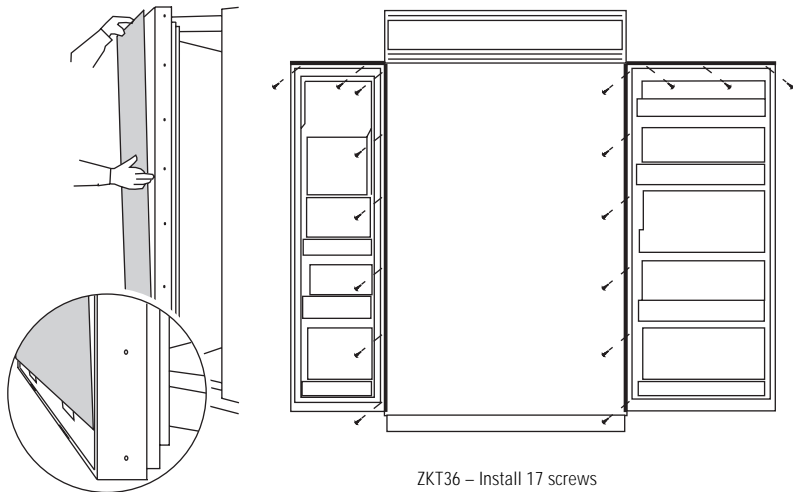

ZKT36 - Install 17 screws

- Place the 3/4" panel on the bottom trim with support bracket tabs inserted into slots. Push the panel back against the steel door, making sure panel is flush to hinge side trim.
- Carefully drill starter holes in panel using a small drill bit.
- Attach the panel to the top and hinge side by installing screws from the back of the trim through the wood panel.
- Follow the same procedure to install fresh food door panel.
- Re-install door handles with original screws.

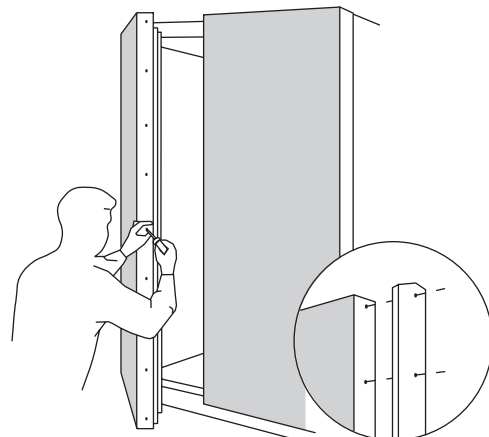

ZKT36 Trim Kit

3/4" Custom Panels

Option 1 Installation

Step 5
Adjust grille panel height

- The refrigerator is shipped with the top case trim secured at the 83" refrigerator height.
- Loosen 2 screws on both sides and raise the top case trim to meet soffit height, from 83" to 84-1/2".
 - Tighten all 4 screws.

Important: Maintain 1-1/2" min. gap between top of doors and bottom of grille panel.

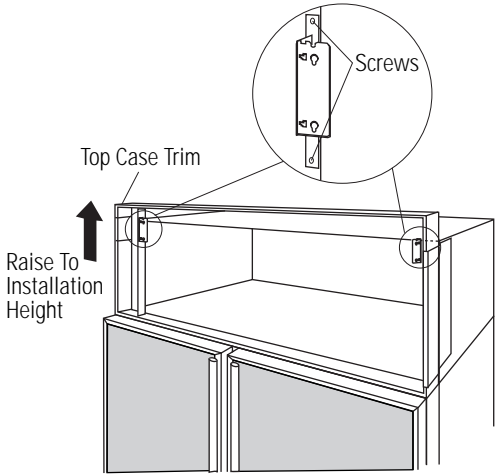

Step 6
Secure 3/4" panel to grille panel support

- Secure the new grille panel support to the back side of the 3/4" panel with #6 screws.
- Be sure the lip on the support panel is over the top of the wood panel.

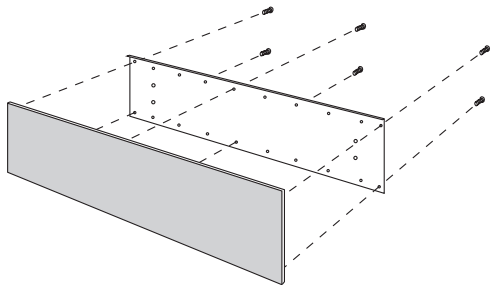
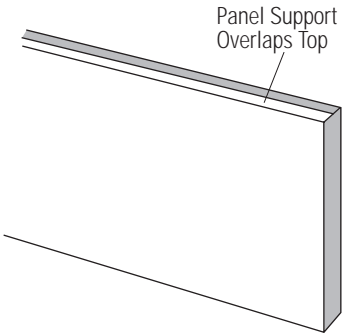

Step 7
Install grille panel

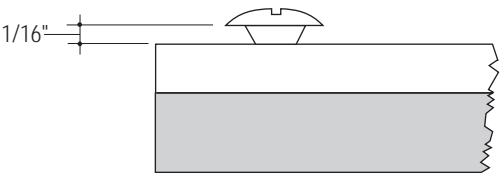
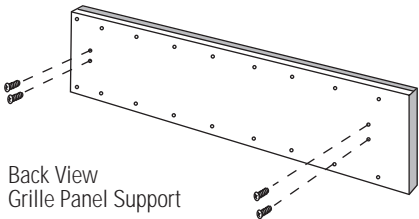

- Install four of the six larger under cut screws such that the top of the screws are 1/16" from the surface of the support.
- Attach the assembled panel to the grille frame by inserting the four protruding screws into brackets located on each side of the grille frame.

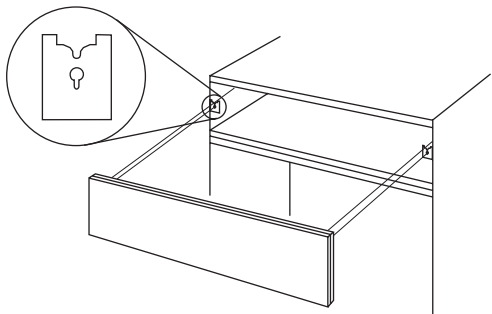

ZKT36
INSTALLATION

ZKT36 Trim Kit

3/4" Custom Panels

OPTION 2
For dispenser model using full-width trim

Step 1
Remove handles & trim

- Open freezer door to 90°.
- Remove the Phillips head screws from the full-length handles.
- Open door fully to stop.
- Remove screws from the aluminum trim, top, bottom and hinge side.
- Remove the trim above and below the dispenser.
- Retain screws and full-length handles. Discard original trim.

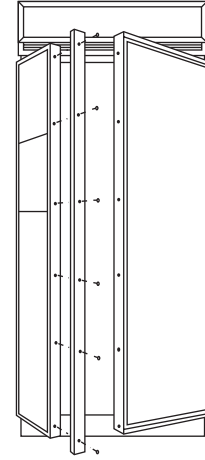

Step 2
Install 3/4" trim

- Attach the new 3/4" trim pieces at the top and hinge side using original screws.

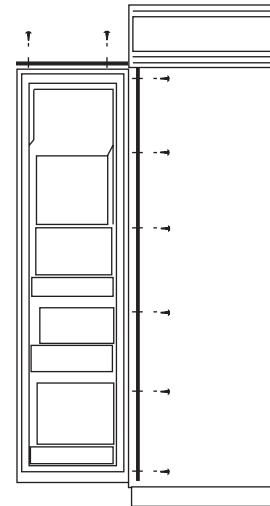

ZKT36
INSTALLATION

Step 3
Install panel support brackets

- Position and mark the location for the support brackets on the back side of the panels. Align all brackets flush with the end of the panels, with tabs protruding over the edge.
- On the bottom of the upper panel, measure dimension A from the hinge side.
- On the bottom of the lower panel, measure dimension B from the hinge side.
- On the top of the lower panel, measure dimension C from the hinge side.
- Secure all brackets with #4 screws provided.

Dimension A
ZKT36-4-3/8"

Dimension B
ZKT36-6-3/4"

Dimension C
ZKT36-4-3/8"

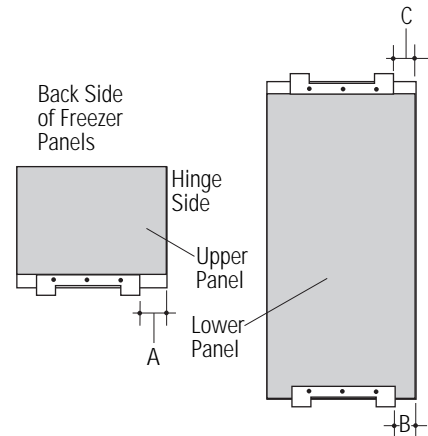

ZKT36 Trim Kit

3/4" Custom Panels

Step 4
Install
panels

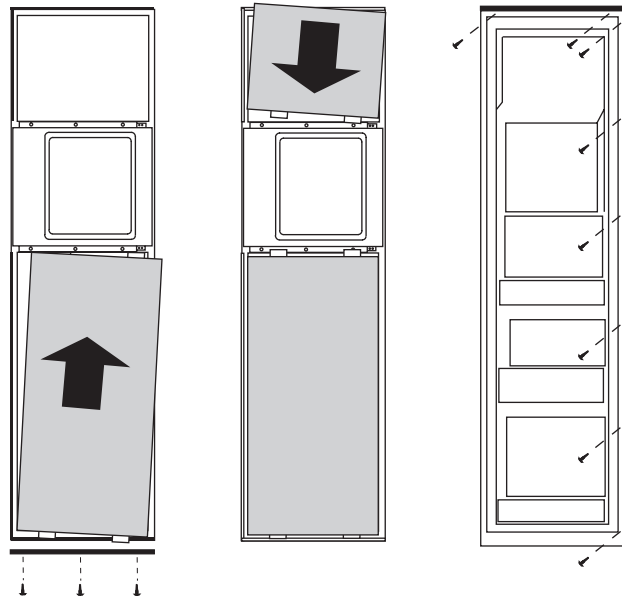

- Install the lower panel by slipping tabs into the slots on the underside of the dispenser trim.
- Hold in position while fitting new bottom trim against the bottom of the door. Tabs should protrude through the bottom trim.
- Install screws up through the bottom trim using stubby Phillips screwdriver.
- Open door and install screws through the back side of the trim and into the panel at the hinge side.
- Place the upper panel onto the top of the dispenser with tabs inserted into the slots.
- Push the panel back against the steel door.
- Open door and install screws through the back of the trim and into the panel, at the top and hinge side.

ZKT36
INSTALLATION

Step 5
Install
handles

- Install door handle using original screws.
- Install panel on fresh food door using the same procedure as in Option 1.
- Install grille panel using the same procedure as in Option 1.

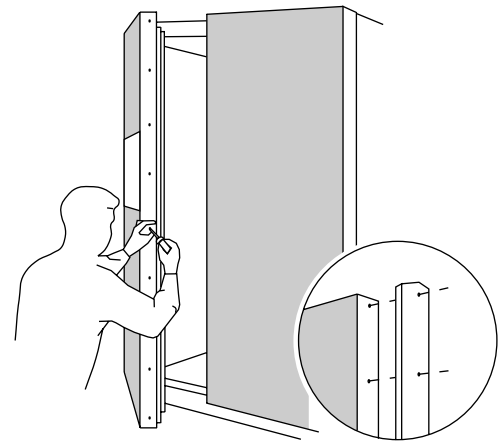

ZKHT1 Trim Kit (For 3/4" Panels)

Support for Custom Handles

Tools and materials

required:

- #2 Phillips screwdriver
- Stubby Phillips screwdriver
- Drill and appropriate bits
- Custom panels
- Custom handles
- Safety glasses

Note: This kit must be used in conjunction with ZKT36 trim kit for 3/4" panel trim.

These instructions are divided into 2 options:

Option 1—For non-dispenser and dispenser models using custom collar trim.

Option 2—For dispenser model using the standard full-width trim.

Kit contents

Parts List:

- Fresh food door extrusion
- Freezer door extrusion for non-dispenser model and dispenser model using custom collar. (Option 1)
- Freezer door extrusion for dispenser model using full-width trim. (Option 2)
- Freezer door handle bracket for dispenser model using full-width trim. (Option 2)

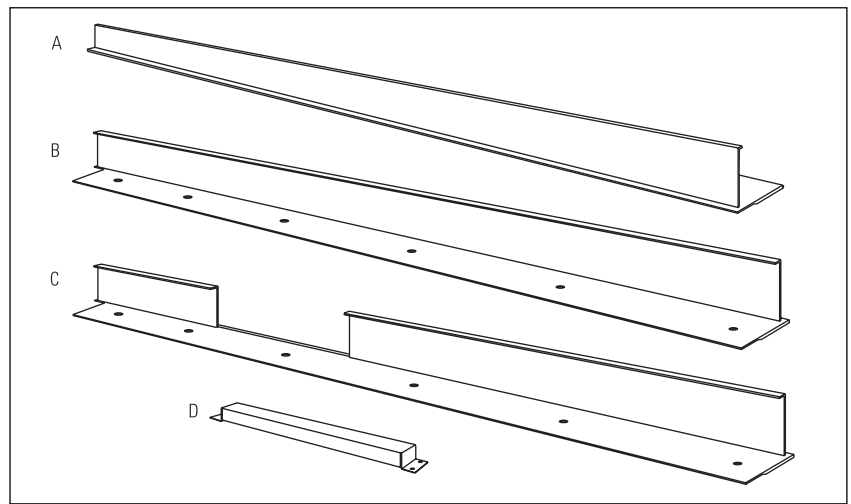

This kit provides the necessary framework to install custom handles of your choice, on 3/4" thick decorator door panels. (Handles not included.) The door extrusions and bracket allow custom handles to be secured to the door structure, rather than the door panels. This kit contains all the necessary parts for dispenser and non-dispenser models. Follow the

instructions in Option 1 when applying custom handles to a non-dispenser model or dispenser model using custom collar trim. Follow the instructions in Option 2 for a dispenser model using the standard full-width dispenser trim.

OPTION 1 For non-dispenser model or dispenser model using custom collar trim

Before you begin

3/4" custom door panels must be routed to accommodate these door extrusions. Rout the panels as illustrated, a maximum of 1/4" deep, and 1-13/16" wide, top to bottom on the handle side.

Note: Optimal final appearance depends on careful routing depth. Do not exceed 1/4" routing depth.

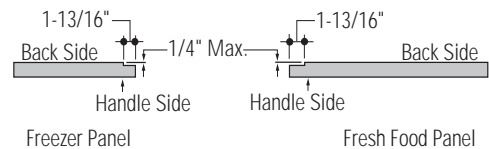

Refer to installation instructions for ZKT36 trim kit for 3/4" custom panels Option 1.

- Follow Step No. 1 to remove the standard aluminum trim.
- Follow Step No. 2 and 3 to attach new 3/4" trim pieces and install panel support brackets.

ZKHT1 Trim Kit (For 3/4" Panels)

Support for Custom Handles

Step 1
Temporarily
mount
door panels

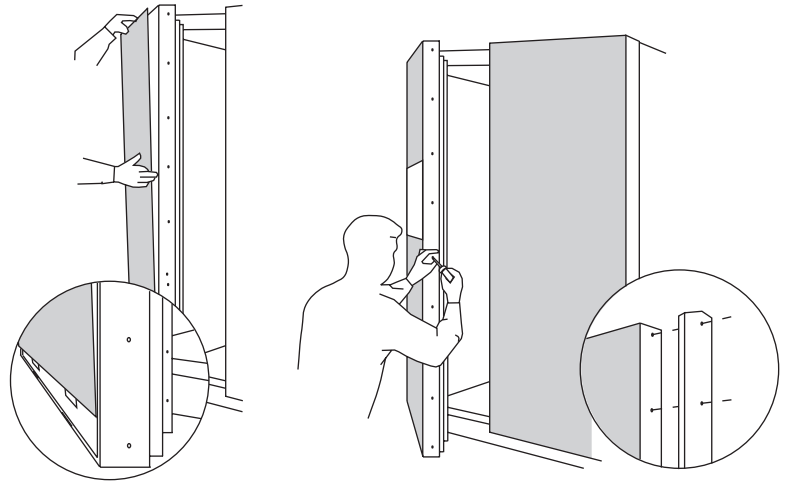

- Place the prepared 3/4" custom door panels on the bottom trim with support bracket tabs inserted into slots.
- Push the panel back against the steel door, making sure panel is flush with hinge side trim.
- Secure the panel to the trim temporarily by driving 2 screws through the back side of the trim at the top.
- Slide door extrusion in between panel and steel door. Temporarily secure with 2 screws.

Step 2
Locate
position
of handles

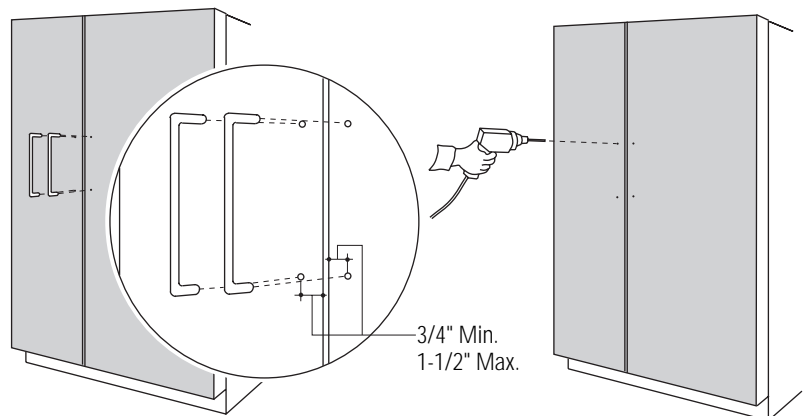

- Determine the desired location of the custom handles and carefully mark centerlines of the screw holes. The handles must be located 3/4" to 1-1/2" from the end of the extrusion.
- Again, with both doors closed, check centerlines of the screw holes to be sure they are parallel to the edge of the door, and level with opposite door.
- Drill 1/16" pilot hole through the panel until it starts into the aluminum extrusion. This will mark the matching location for drilling a clearance hole when assembling the extrusion, panel and handle.

ZKHT1 Trim Kit (For 3/4" Panels)

Support for Custom Handles

Option 1 Installation

Step 3 Assemble panel, extrusion and handle

- Remove the door extrusions and door panels.
- Drill 1/16" pilot hole through extrusion.
- Drill clearance holes through the panel and extrusion.
- Assemble the door panel, extrusions and custom handle.
- Install screw(s) long enough to pass through the extrusion, door panel and into the handle.

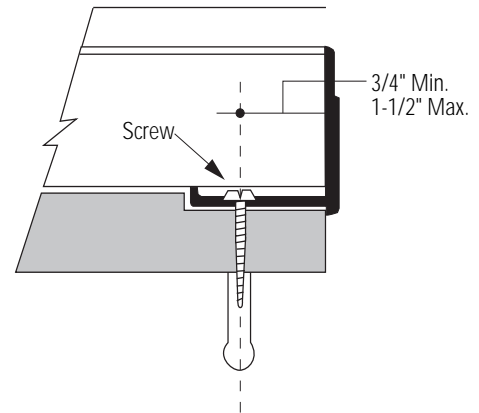

Step 4 Mount assembled panels

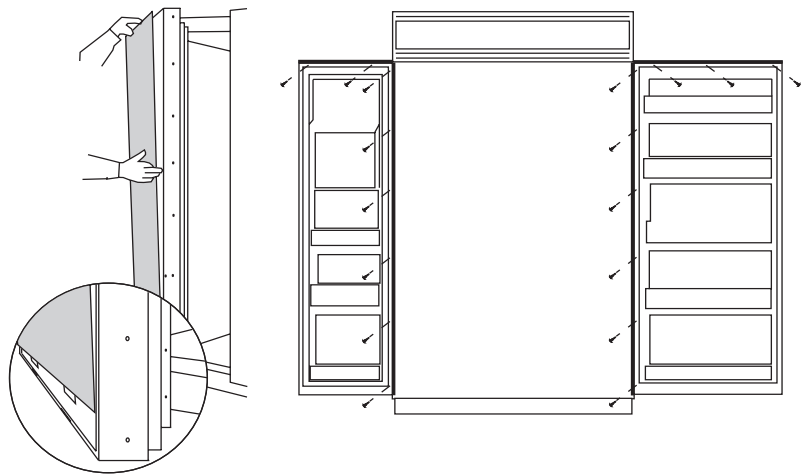

- Place assembled panel onto bottom trim with support bracket tabs inserted into slots.
- Push the panel back against the steel door with door extrusion flush to the handle side of the door.
- Open door fully to stop.
- Install screws at the top, hinge side and end of door extrusion.



ZKHT1 Trim Kit (For 3/4" Panels)

Support for Custom Handles

Option 1 Installation

OPTION 2
For dispenser model using full-width trim

Before you begin

Note: Optimal final appearance depends on careful routing depth. Do not exceed 1/4" routing depth.

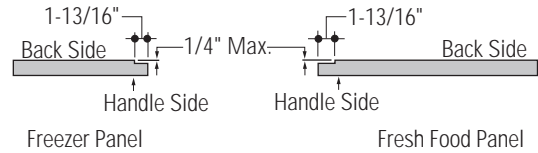

All 3 custom door panels must be routed to accommodate the door extrusions. Route the panels as illustrated, max. 1/4" deep, 1-13/16" wide, top to bottom on the handle side.

Refer to installation instructions for ZKT36 trim kit, Option 2.

- Follow Step No. 1 to remove standard aluminum trim.
- Follow Step No. 2 and 3 to attach new 3/4" trim pieces and install panel support brackets.

Step 1
Locate position of handle

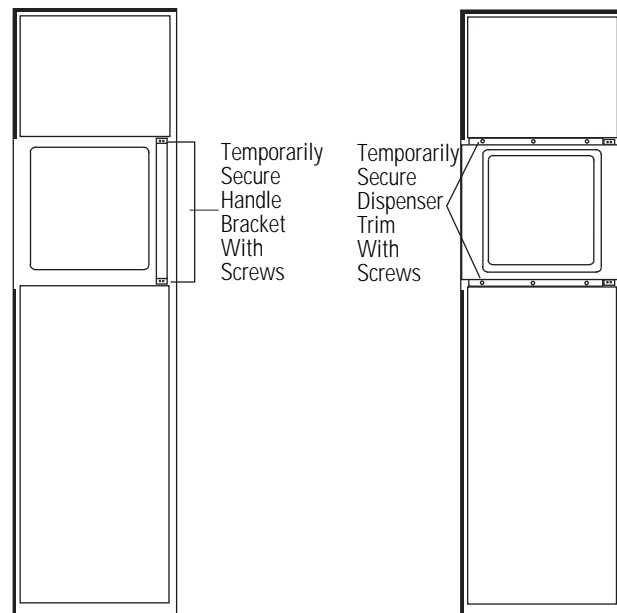

Note: The custom handle must be installed against the handle bracket. The custom handle cannot exceed 11-3/4" length.

- Position the handle bracket onto the steel door by matching existing screw holes on the door and bracket.
- Re-install dispenser trim, temporarily.
- Determine the desired location of the custom handle and carefully mark centerlines of the screw holes.
- Drill 1/16" pilot hole through the trim until it starts into the handle bracket. This marks the same location onto the bracket.
- Remove dispenser trim and bracket.

ZKHT1 Trim Kit (For 3/4" Panels)

Support for Custom Handles

Option 2 Installation

Step 2 Install custom handle

- Drill clearance holes through the handle bracket and the dispenser trim.
- Install screw(s) long enough to pass through the handle bracket, dispenser trim and into the custom handle.

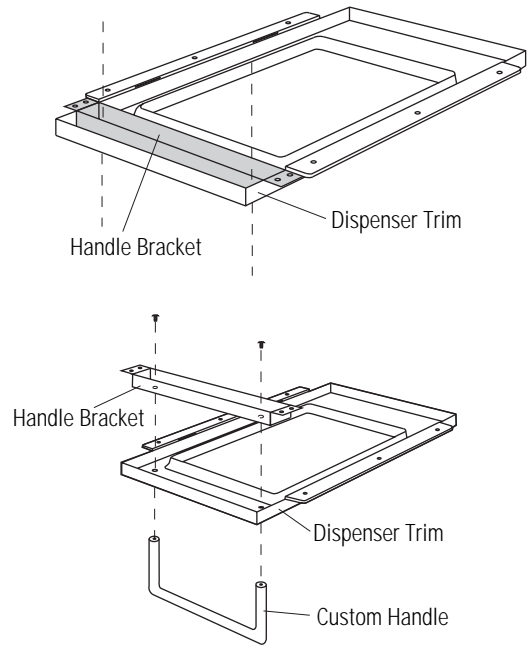

Step 3 Mount assembled dispenser trim

- Mount assembled dispenser trim with handle onto the door.
- Drive 2 screws through the top and bottom of the handle bracket into the steel door.
- Re-install 3 screws at top and bottom of dispenser trim.

Important: The handle bracket must be secured to the steel door. If it is not secured properly, the dispenser trim will pull away from the door.

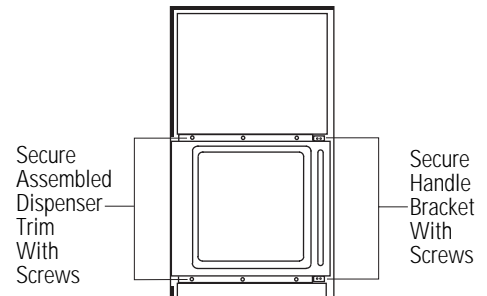

- Again, refer to ZKT36 trim kit, Option 2.
- Follow Step 4 to install freezer door panels and bottom trim.
 - Slide freezer handle side extrusion in between panels and steel door. Secure with screws.
 - To install fresh food handle, follow the same procedure as in Option 1.

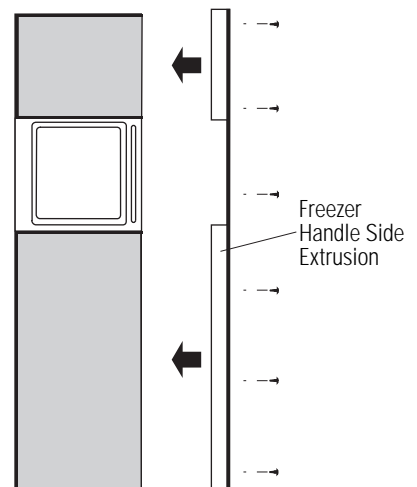

ZKHT1
INSTALLATION

ZKHSS1 for 1/4" Panels

Tubular Stainless Steel Handles

This kit provides for the installation of Stainless Steel custom handles on 1/4" thick decorator door panels. The door extrusions allow these custom handles to be secured to the door structure, rather than to the custom panels. This kit contains all the necessary parts for dispenser and non-dispenser models.

Tools and materials required:

- #2 Phillips screwdriver
- Drill and 1/8", 9/32" bits
- Custom door panels
- Safety glasses
- Center punch
- Masking tape
- Hammer
- Pencil
- 1/2" thick 12" x 12" min. piece of plywood to protect floor when drilling
- For stainless steel panels wear gloves to protect against sharp edges.

Parts List:

- A. Fresh food door extrusion
- B. Freezer door extrusion
- C. 2 Stainless tubular handles
- D. 10 Spacer rings (for Stainless panels ONLY)
(8 required, 2 extra)
- E. 8 Handle standoffs
- F. 10 Screws for mounting handle standoffs
(8 required, 2 extra)
- G. 10 Set screws (8 required, 2 extra)
- H. 3/32" Allen wrench for set screws

Note: It is best that 2 people install this kit.

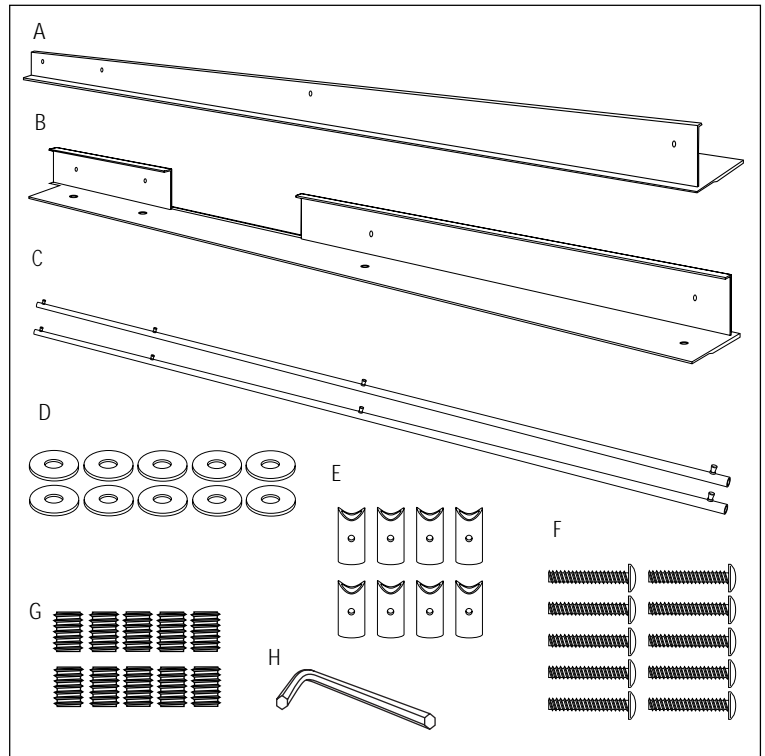

Step 1: Remove Handles

- Open doors to 90°. Remove the screws from the full-length handles of both doors.
- Retain screws, discard handles.
- Locate the 2" x 2" adhesive foam pads packed with the refrigerator. Apply pads to the doors as shown. Corner pads should be as close to inside corners as possible.

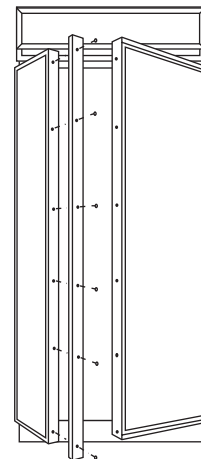

Note: If a custom collar is to be used, order ZWCD1 Trim Kit for 36" and 42" wide models. Order ZWCD2 for 48" wide models.

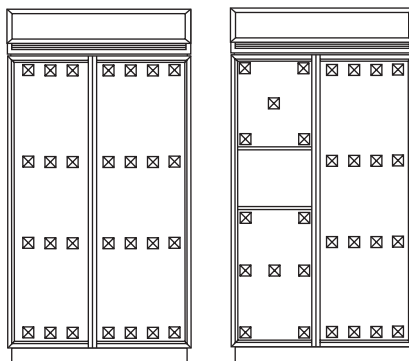

ZKHSS1 for 1/4" Panels

Tubular Stainless Steel Handles

Step 2:
Match
Handle Extrusions
to Handle

**FOR CUSTOM
WOOD
PANELS**

See Step 2A
for Stainless
Steel panels

- Cut a piece of corrugated to use as a pad to protect the panel finish. Use 1/2" thick section of plywood to protect flooring when drilling.
- Place custom panels on the pad, appearance side down.

Note: If panels are wood, be sure to note which end is the top so that wood grain is in the correct direction on both (or all 3) panels.

- On the back side of the panel – at the handle side, measure and mark 1/4" below the top edge of the panel with a pencil.
- Slip panels into new extrusion on the handle side of the panels.
- Align the extrusion at the pencil mark, 1/4" below the top of the panel.
- Follow the same procedure on the opposite panel.
- Tape the extrusions to the panels to prevent movement.
- Center punch and drill 1/8" pilot holes through the holes in the extrusion and into the panel.
- Turn panel over. On the appearance side, use 9/32" bit to enlarge clearance hole.

IMPORTANT: Hole locations must be exact to accept handle standoff and handle assembly.

For models with full width dispenser trim and 2 piece freezer panels:

- Measure 1/4" from the top of the upper panel and 1/4" from the bottom of the lower panel. Mark with pencil on the back handle side.
- Align the extrusion on the pencil mark as shown, top and bottom.

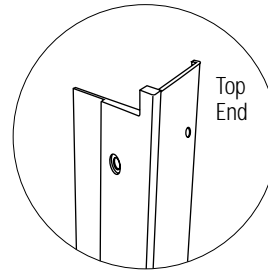

Note: Be sure to orient extrusions and handles correctly. The top ends of the extrusions are cutout to fit the shape of the top of the door.

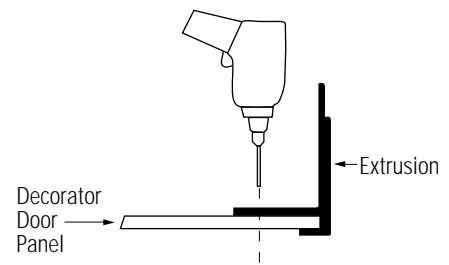
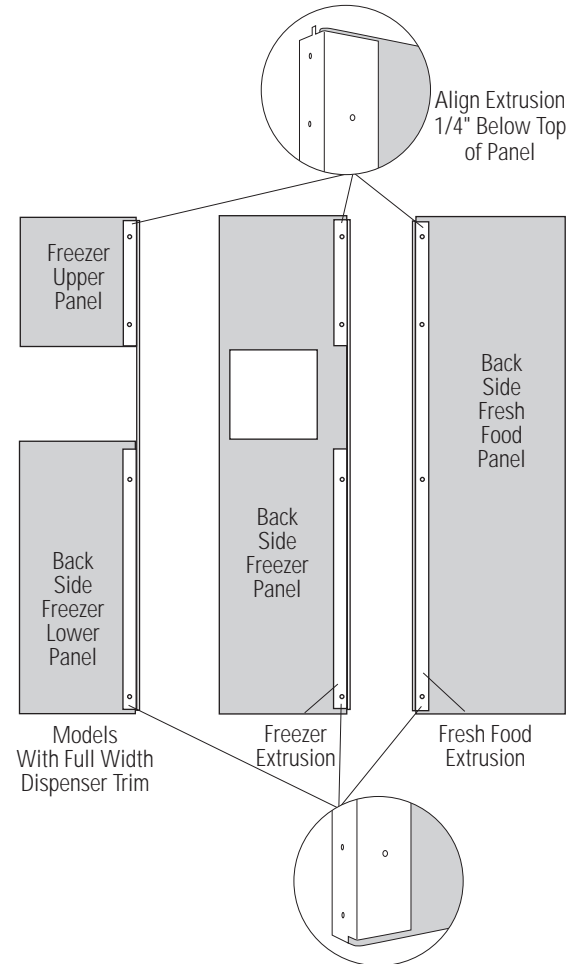

ZKHSS1
INSTALLATION

ZKHSS1 for 1/4" Panels

Tubular Stainless Steel Handles

Step 2A:

FOR STAINLESS STEEL PANELS

If you are installing these handles onto Stainless Steel panels:

Use extreme caution if you are drilling through stainless steel panels. Stainless panels must be handled gently. Do not kneel on stainless steel panels. It will leave a permanent dent. Do not remove protective plastic covering until final installation.

- Place supplied filler panel (corrugated) on floor to use as a pad.
- On the back side of the panel—at the handle side, measure and mark 1/4" below the top edge of the panel.

For models with full width dispenser trim and 2-piece freezer panels:

- Measure and mark 1/4" below the top edge of the upper panel.
- Measure and mark 1/4" above bottom edge of lower panel.
- Slip panels into the new extrusion, flush against inner edge, on the handle side.

- Align extrusion to pencil mark(s) as shown in Step 2. Mark each screw hole location with pencil.
- Tape extrusions to panels to prevent movement.
- Place panel on plywood section, appearance side down. Be sure plywood is clean without nicks and burrs. Center punch at each screw hole location.
- Drill 1/8" pilot hole. Use 9/32" bit to enlarge clearance hole.
- Measure and cut a 2" wide strip, top to bottom off the corrugated panels. This will allow room for spacer rings between the stainless panel and extrusion.

Step 3:
Install
Standoffs
onto Handles

- Place a handle standoff on each attachment post along the handle. Position the set screw hole on each standoff to point to the floor.
- Install set screws into the bottom of each standoff, using the Allen wrench provided. The standoff should be tight against the handle.

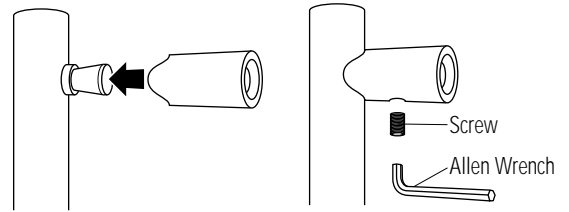

Step 4:
Install
Handles
and
Panels

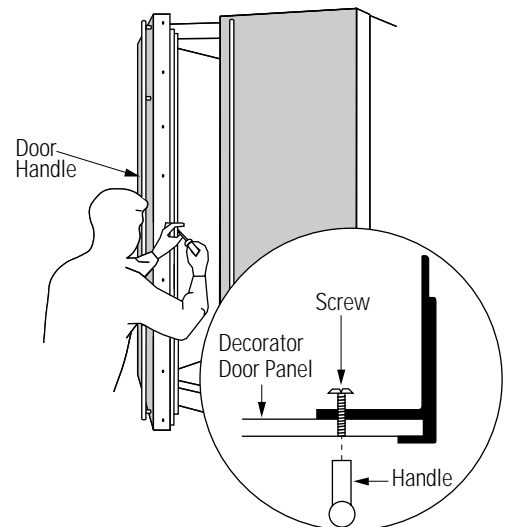
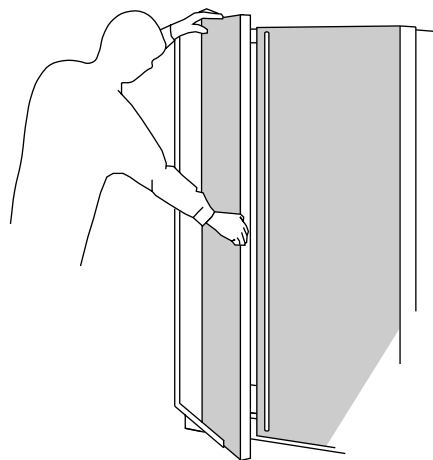
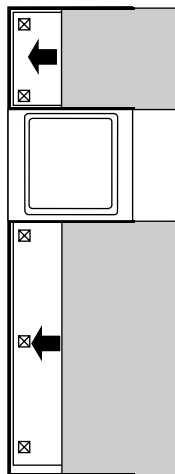

ZKHSS1 INSTALLATION

FOR CUSTOM WOOD PANELS

See Step 4A
for Stainless
Steel panels

- Press foam pads against steel doors to temporarily reduce thickness.
- Slide panels into the door trim. Leave about 4" of the panel exposed to allow room to install the handle extrusion.
- Place extrusion onto back side of panel, install mounting screws through the extrusion and the custom panel.

- Screw handle to panel, starting at the top. Moving down the handle, drive each screw partially into the standoff, alternating back to the top until the handle is tight against the panel.
- Slide the assembly into the door frame until the extrusion fits firmly against the steel door.
- Reinstall original screws into the door extrusion.

ZKHSS1 for 1/4" Panels

Tubular Stainless Steel Handles

Step 4A:
Install
Handles
and Panels

**FOR
STAINLESS
STEEL
PANELS**

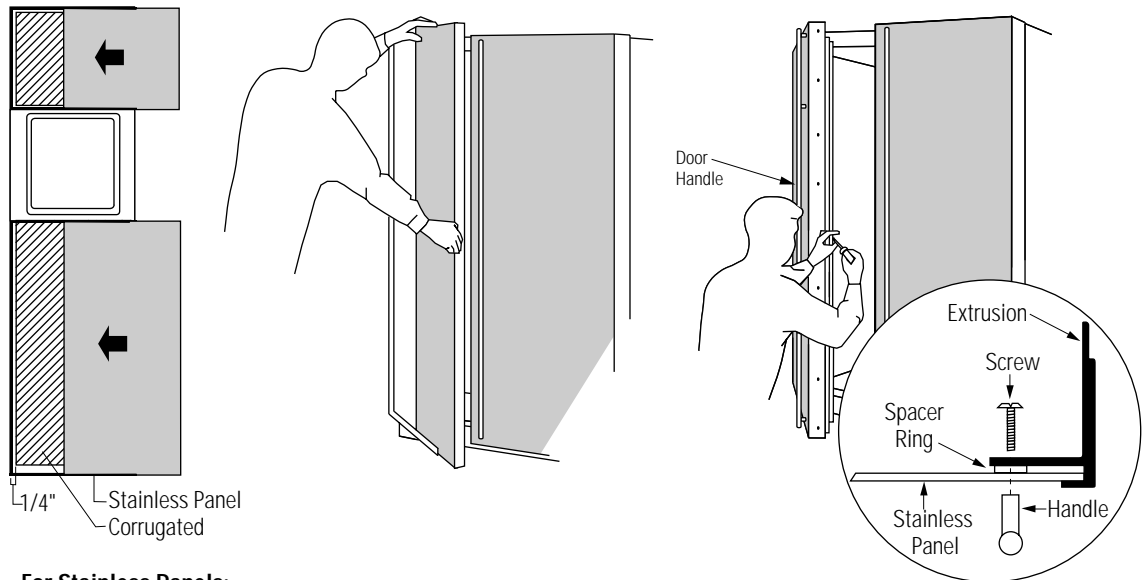

For Stainless Panels:

- Press foam pads against steel doors to temporarily reduce thickness.
- Crimp top and bottom edges of corrugated.
- Slide corrugated onto doors, leave about 1/4" gap between edge of corrugated and hinge side.

Note: Panels have a protective plastic covering. Peel away just enough to allow panel to slide into trim and to clear handle mounting screws. The plastic covering will keep the panels clean during the installation process.

- Slide panels into the door trim. Leave about 4" of the panel exposed to allow room to install the handle extrusion.

Be sure to maintain 1/4" gap between corrugated and hinge side trim.

- Place a spacer ring over each of the 4 screw holes on the extrusion. Use tape to hold in place.
- Place extrusion onto back side of panel. Use a pencil to punch hole in tape over spacer rings and align with screw holes.
- Install 4 mounting screws through the extrusion and panel.
- Screw handle to panel, starting at the top. Moving down the handle, drive each screw partially into the standoff, alternating back to the top until the handle is tight against the panel.
- Slide the assembly into the door frame until the extrusion fits firmly against the steel door.
- Reinstall original screws into the door extrusion.

Raised Panel on 1/4" Thick Backing:

A raised panel design secured to a 1/4" thick backing (screwed or glued) can be used with this handle kit.

- Cut the 1/4" thick panels to size.
- Fabricate the raised panel to allow 1-1/4" clearance from the hinge side to avoid striking adjacent cabinetry.
- Allow 5/16" clearance at the top, bottom and handle side edges to allow for the trim flange.
- Total thickness should not exceed 3/4".
- Countertops adjacent to the refrigerator installation should be mitered 45°.

Note: Longer screws, obtained locally, will be required to accommodate panel thickness. Use stainless steel #10-32x1-1/4" truss Phillips head screws.

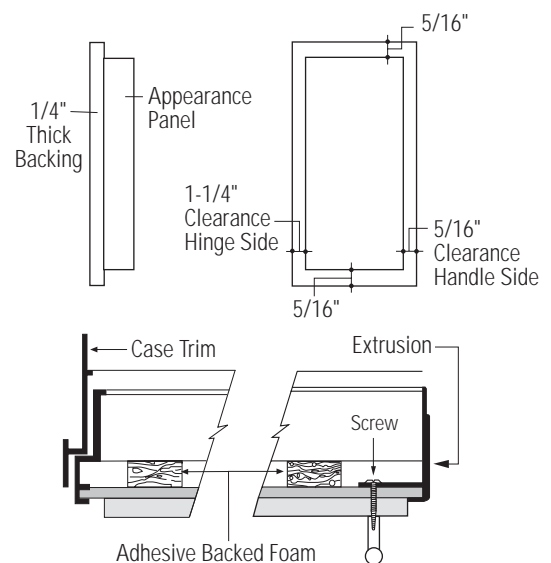

**ZKHSS1
INSTALLATION**

ZKHTSS1 for 3/4" Panels

Tubular Stainless Steel Handles

This kit provides for the installation of Stainless Steel custom handles on 3/4" thick decorator door panels. The door extrusions allow these custom handles to be secured to the door structure, rather than to the custom panels. This kit contains all the necessary parts for dispenser and non-dispenser models.

This kit must be used in combination with ZKT36, ZKT42 or ZKT48 trim kit.

The ZKT trim kits provide the framework to support 3/4" thick panels. This kit provides handle side extrusions and handles to match that ZKT framework.

Note: It is best that 2 people install this kit.

Tools and materials required:

- #2 Phillips screwdriver
- Drill and 1/8", 9/32" bits
- Custom door panels
- Safety glasses
- Center punch
- Masking tape
- Hammer
- Pencil
- 1/2" thick 12" x 12" min. piece of plywood to protect floor when drilling
- For stainless steel panels wear gloves to protect against sharp edges.

Parts List:

- A. Fresh food door extrusion
- B. Freezer door extrusion
- C. 2 Stainless tubular handles
- D. 8 Handle standoffs
- E. 10 Screws for mounting handle standoffs (8 required, 2 extra)
- F. 10 Set screws (8 required, 2 extra)
- G. 3/32" Allen wrench for set screws

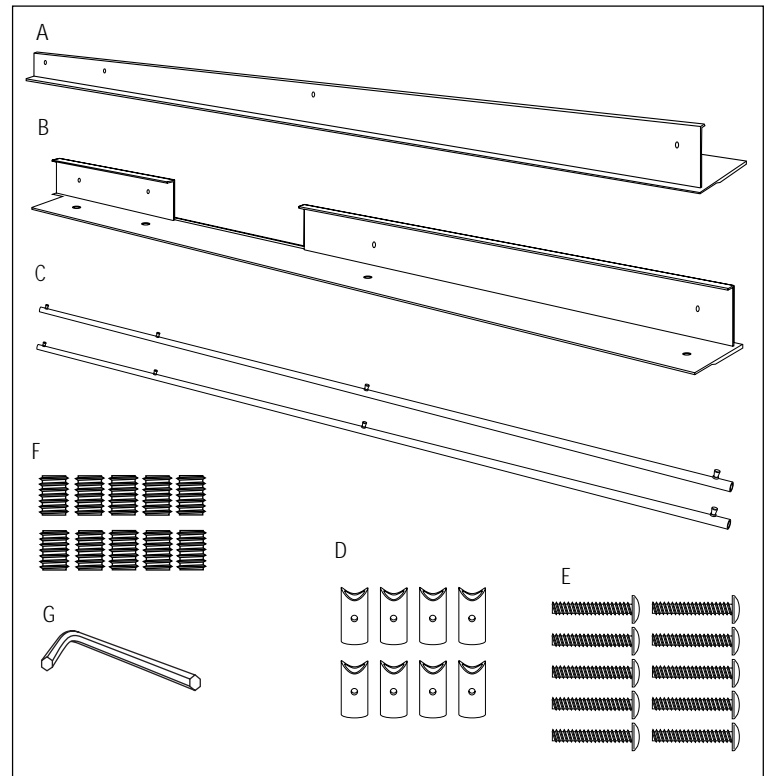

Before
You
Begin

- 3/4" custom panels must be routed to accommodate these handle extrusions. Rout the panels as illustrated, 1/4" deep, and 1-13/16" wide, top to bottom on the handle side.
- Follow the instructions in the ZKT trim kit to install support brackets to the bottom of the fresh food and freezer panels. For models with full width dispenser trim, install the support bracket to the bottom of the lower panel only. Do not install a bracket to the top of the lower panel or the bottom of the upper panel as shown in the ZKT trim kit instructions. These brackets are not required for this kit.

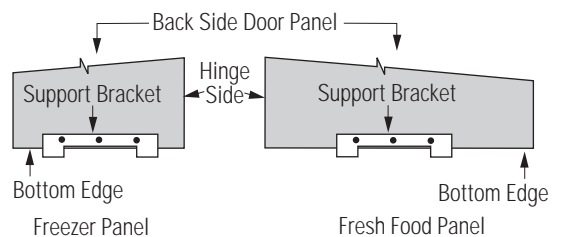
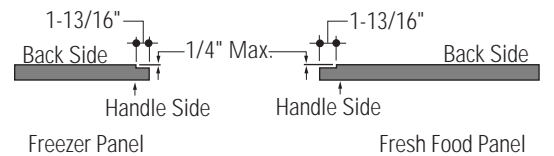

Install bottom support brackets only.

ZKHTSS1 for 3/4" Panels

Tubular Stainless Steel Handles

Step 1: Remove Handles

- Open doors to 90°. Remove the screws from the full-length handles of both doors.
- Retain screws, discard handles.

Note: If a custom collar is to be used, order ZWCD1 Trim Kit for 36" and 42" wide models. Order ZWCD2 for 48" wide models.

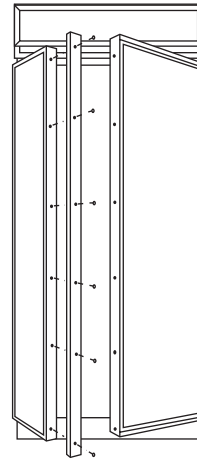

Step 2: Match Handle Extrusions to Panels

- Cut a piece of corrugated to use as a pad to protect the panel finish. Use 1/2" thick section of plywood to protect flooring when drilling.
- Place custom panels on the pad, appearance side down.

Note: If panels are wood, be sure to note which end is the top so that wood grain is in the correct direction on both (or all 3) panels.

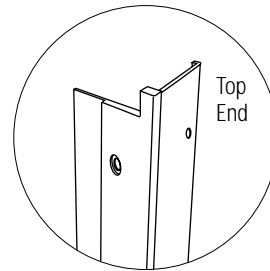

Note: Be sure to orient extrusions and handles correctly. The top ends of the extrusions are cutout to fit the shape of the top of the door.

- Place new extrusion against the handle side of the panels.
- Align the extrusion evenly with the top and bottom of the panel.
- Follow the same procedure on the opposite panel.
- Tape the extrusions to the panels to prevent movement.
- Center punch and drill 1/8" pilot holes through the holes in the extrusion and into the panel.
- Turn panel over. On the appearance side, use 9/32" bit to enlarge clearance hole.

IMPORTANT: Hole locations must be exact to accept handle standoff and handle assembly.

For models with full width dispenser trim and 2 piece freezer panels:

- Carefully, align the top of the upper panel and the bottom of the lower panel with extrusion ends.

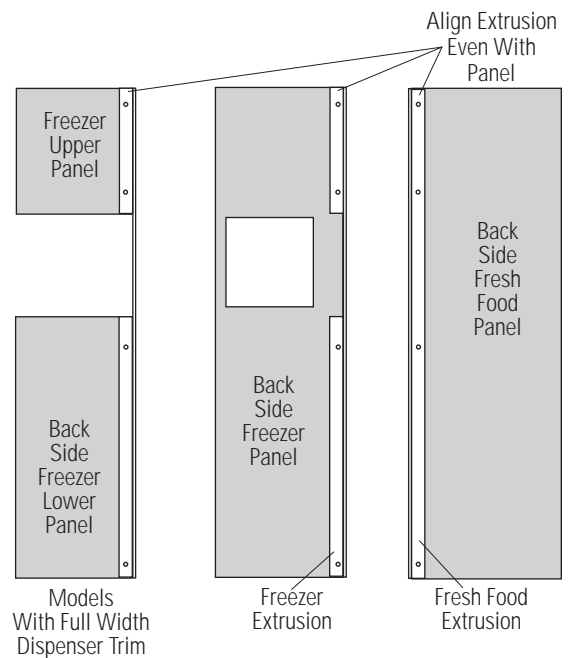

ZKHTSS1 for 3/4" panels

Tubular Stainless Steel Handles

Step 3:
Install
Standoffs
onto Handles

- Place a handle standoff on each attachment post along the handle. Position the screw hole on the standoff to point to the floor.
- Install set screws into the bottom of each standoff, using the Allen wrench provided. The standoff should be tight against the handle.

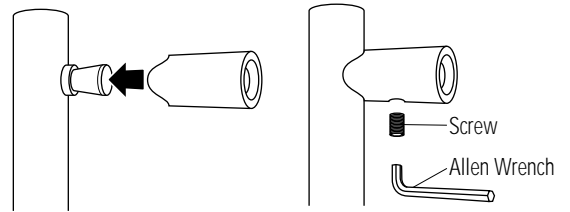

Step 4:
Install
Handles

- Start mounting screws through the extrusion and just through the custom panel.
- Stand panels up on the hinge side and hold to access the appearance side. Place handle against mounting screws on the appearance side, drive top screw from the back of the extrusion partially into the standoff.
- Going down the handle, drive each screw partially into the standoff, alternating back to the top until the handle is tight against the door.
- Remove tape.

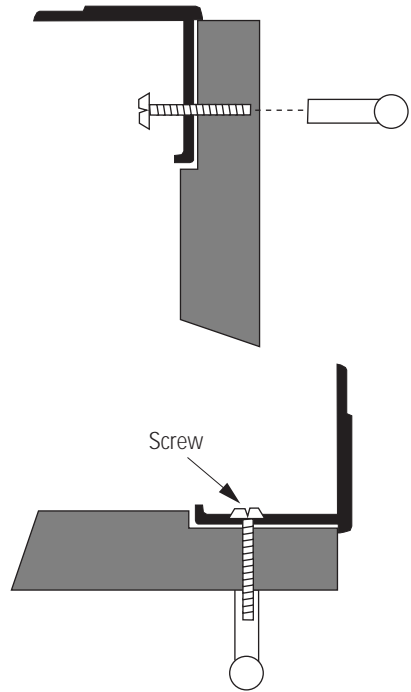

Step 5:
Install
Assembled
Panels

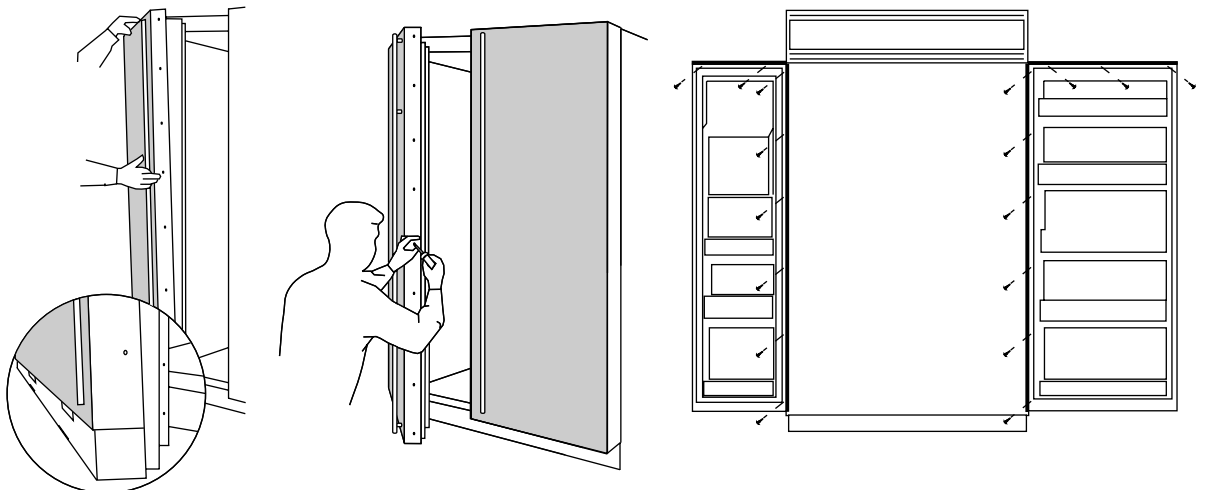

It is best that 2 people perform this step.

- Place panel/handle assembly onto the bottom trim with support bracket tabs inserted into slots.
- Push and hold the panel back against the steel door with door handle extrusion flush to the handle side of the door.
- Reinstall original screws into the door extrusion.
- Open the door fully to stop.

- Install screws at the top, and hinge side.
- Follow the same procedure on the opposite door.

ZKHTSS1 for 3/4" Panels

Tubular Stainless Steel Handles

Step 5
Install
Assembled
Panels
(continued)

For models with full width dispenser trim and 2 piece freezer panels:

It is best that 2 people perform this step.

- Carefully, lift the assembled panel to the case trim.
Hold both panels so they do not twist the extrusion.
- Insert the support bracket tabs into the bottom trim.
- Push and hold the panel back against the steel door.
- Reinstall original screws into the door extrusion.
- Open the door fully to stop.
- Install screws at the top, and hinge side.

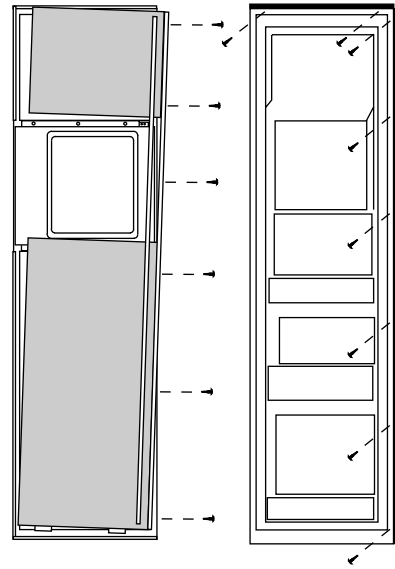

ZWCD1 Trim Kit

Custom Dispenser Collar

Tools and materials required:

- #2 Phillips screwdriver
- Drill and appropriate bits
- Custom door panels
- Safety glasses

Kit contents

Parts List:

- A. Collar trim
(Both black and white trim included)
- B. Top bracket
- C. Bottom bracket
- D. Screws (2)

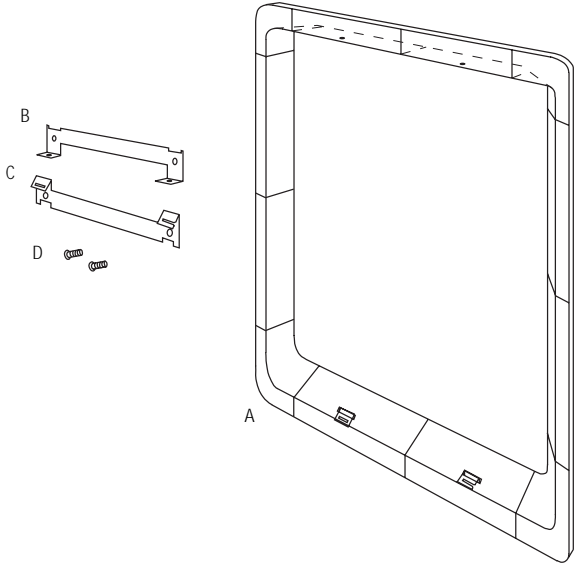

This kit provides for the use of a custom dispenser collar trim, replacing the standard full-width trim. This kit can be used alone, or combined with one or all other trim kits.

Select panel size

1/4" Thick Custom Panels

3/4" Thick Custom Panels with Standard Handles

3/4" Thick Custom Panels with Custom Handles

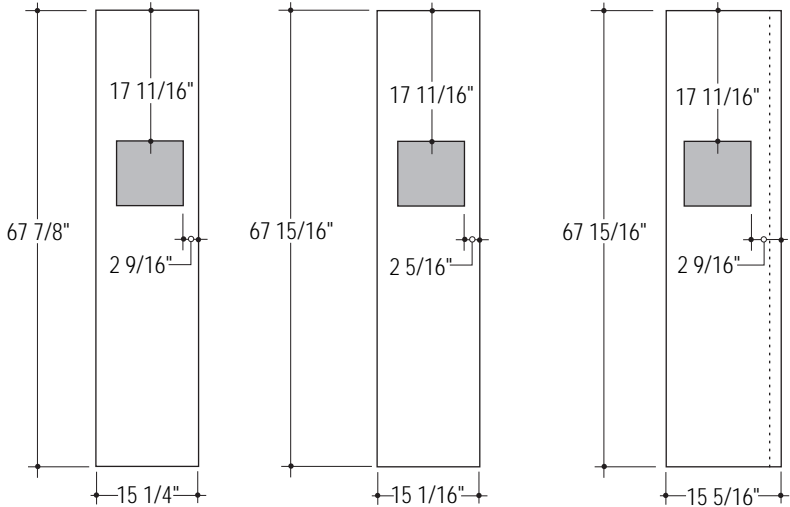

The overall size of the panel is determined by the application being used.

- 1/4" thick panels using the standard handles or optional custom handles.
- 3/4" thick panels using standard handles, or

- 3/4" thick panels using optional custom handles. Select the panel size accordingly.

ZWCD1 Trim Kit

Custom Dispenser Collar

Cut dispenser hole and rout door panel

The use of this custom collar trim requires that the hole for dispenser be located and cut *very accurately*. 3/4" door panels must be routed on all 4 sides of the dispenser cutout.

Rout the back side of the panel 1/4" deep and 7/8" wide, flush with the edge of the cutout.

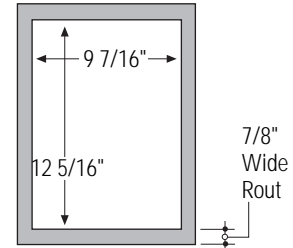

The Cutout is 9 7/16" wide by 12 5/16" high. 3/4" panels must be routed on all four sides of the cutout. Rout the back side of the panel 1/4" deep. 7/8" wide.

Note: 1/4" door panels do not require routing.

Install collar brackets and trim

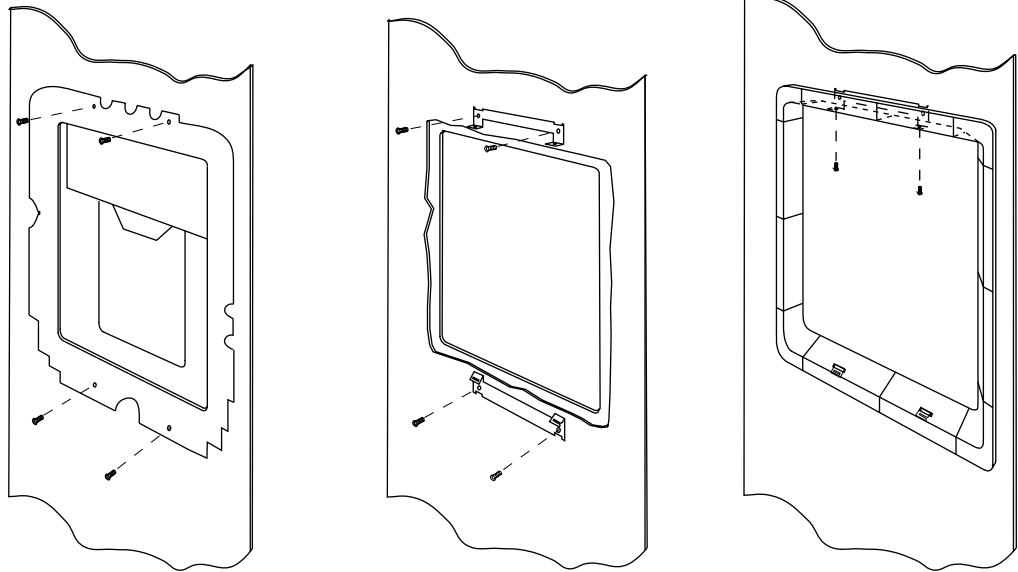

Select the door panel size for your application.

- If using the standard 1/4" trim, follow the installation instructions packed with the product.
- When using another optional trim kit, use the instructions provided with that kit to install the panel trim and/or custom handles.
- Remove the aluminum trim above and below the dispenser. Discard trim.
- Remove and discard the standard full-width dispenser trim.
- Remove 2 screws above and below the dispenser recess. Retain screws.
- Secure top and bottom brackets to the dispenser, using the screws previously removed.
- Install the custom panels according to the appropriate installation instructions.
- Select the black or white collar trim according to appearance desired.
- Match the indentations on the collar trim to the tabs on the lower bracket. Push the collar flush against the door.
- Drive 2 screws (provided) upwards through the collar and into the brackets.

Note: While performing installations described in this book, safety glasses or goggles should be worn.

To obtain specific information concerning any Monogram product or service, call GE Answer Center® consumer information service at 800.626.2000—any time, day or night.

For Monogram™ local service in your area, call 1-800-444-1845.

Note: Product improvement is a continuing endeavor at General Electric. Therefore, materials, appearance and specifications are subject to change without notice.



General Electric Company
Louisville, KY 40225

Pub. No. 49-6964-2
Part No. 162D9630P003
© 1999 GE Appliances
Printed in U.S.A. (NAI 484) 12/99
7758